

SERIES 1460

INTELLIGENT ABSOLUTE RESOLVER INTERFACE MODULE

USER'S MANUAL

Catalog Number 1460-595M

This manual is written to explain the operation of the following AMCI Modules for the Square D SY/MAX® I/O System:

1461

1462

1461-01

1461A

1462A

1461-01A

General Information

Important User Information

The products and application data described in this manual are useful in a wide variety of different applications. Therefore, the user and others responsible for applying these products described herein are responsible for determining the acceptability for each application. While efforts have been made to provide accurate information within this manual, AMCI assumes no responsibility for the application or the completeness of the information contained herein.

UNDER NO CIRCUMSTANCES WILL ADVANCED MICRO CONTROLS, INC. BE RESPONSIBLE OR LIABLE FOR ANY DAMAGES OR LOSSES, INCLUDING INDIRECT OR CONSEQUENTIAL DAMAGES OR LOSSES, ARISING FROM THE USE OF ANY INFORMATION CONTAINED WITHIN THIS MANUAL, OR THE USE OF ANY PRODUCTS OR SERVICES REFERENCED HEREIN.

Throughout this manual the following two notices are used to highlight important points.



WARNING

WARNINGS tell you when people may be hurt or equipment may be damaged if the procedure is not followed properly.



CAUTION

CAUTIONS tell you when equipment may be damaged if the procedure is not followed properly.

No patent liability is assumed by AMCI, with respect to use of information, circuits, equipment, or software described in this manual.

The information contained within this manual is subject to change without notice.

Standard Warranty

ADVANCED MICRO CONTROLS, INC. warrants that all equipment manufactured by it will be free from defects, under normal use, in materials and workmanship for a period of [1] year. Within this warranty period, AMCI shall, at its option, repair or replace, free of charge, any equipment covered by this warranty which is returned, shipping charges prepaid, within one year from date of invoice, and which upon examination proves to be defective in material or workmanship and not caused by accident, misuse, neglect, alteration, improper installation or improper testing.

The provisions of the "STANDARD WARRANTY" are the sole obligations of AMCI and excludes all other warranties expressed or implied. In no event shall AMCI be liable for incidental or consequential damages or for delay in performance of this warranty.

Returns Policy

All equipment being returned to AMCI for repair or replacement, regardless of warranty status, must have a Return Merchandise Authorization number issued by AMCI. Call (203) 585-1254 with the model number and serial number (if applicable) along with a description of the problem. A "RMA" number will be issued. Equipment must be shipped to AMCI with transportation charges prepaid. Title and risk of loss or damage remains with the customer until shipment is received by AMCI.

24 Hour Technical Support Number

24 Hour technical support is available on this product.

For technical support, call (203) 583-7271.

TABLE OF CONTENTS

Important User Information	Inside Cover
Standard Warranty	Inside Cover
Returns Policy	Inside Cover
24 Hour Tech. Support Line	Inside Cover
1.0: OBJECTIVE	1
2.0: INTRODUCTION	1
3.0: SERIES 1400 FAMILY	1
4.0: INSTALLATION	
4.1 Power Requirements	2
4.2 Installing the Module	2
4.3 Installing the Transducer Cable	2
5.0: FUNCTIONAL DESCRIPTION	
5.1 Front Panel Description	3
5.2 Function Indicators	4
5.3 Function and Parameter Descriptions	
5.3.1 Position Function	4
5.3.2 Tachometer Function	5
5.3.3 Transducer Type Parameter	5
5.3.4 Scale Factor Parameters	
Full Scale Number of Turns Parameter	5
Full Scale Count Parameter	5
Calculated Counts per Turn	5
5.3.5 Circular Offset Parameter	6
5.3.6 Linear Offset Parameter	6
5.3.7 Decimal Point Parameter	7
5.4 Fault Diagnostics	7
6.0: PROGRAM MODE	8
7.0: KEYBOARD DESCRIPTION	
7.1 Display Mode of Operation	9
7.2 Program Mode of Operation	10
8.0: PROGRAMMING THE 1461/2 ABSOLUTE RESOLVER ENCODER MODULE	
8.1 Transducer Type Parameter	11
8.2 Scale Factor Parameters	12
8.3 Circular Offset Parameter	12
8.4 Auto Zero Feature	13
8.5 Linear Offset Parameter	13
8.6 Decimal Point Parameter	13

TABLE OF CONTENTS (cont'd)

9.0:	ADDRESSING THE 1460 MODULE	14
10.0:	1460 MODULE REGISTER DATA FORMAT	15
11.0:	SPECIFICATIONS	16
APPENDIX A:	1461 ADDITIONAL INSTRUCTIONS	A-1
APPENDIX B:	ADDITIONAL INSTRUCTIONS 1461-01	B-1
PRINTS:		
B1153	Series 1400 Outline Drawing	P-1
B1187	1461-01 Outline Drawing and Connector Pin-out	P-2
B1016 Rev. A	HIT-20-(x) Transducer Outline Drawing	P-3
B1190	CTIW-(x) Transducer Cable Drawing	P-4
B1040 Rev. A	CTT-(x) Transducer Cable Drawing	P-5
B1091 Rev. A	C2TT-(x) Transducer Cable Drawing	P-6
B1156	22115600 Transducer Mounting Bracket	P-5
B1158	HIT-20-(x) In 22115600 Transducer Mounting Bracket	P-6
B1160 Rev. B	AutoTech SAC-RL210-G128M Transducer Cable Drawing	P-7
B1191	AutoTech SAC-RL210-G128M Transducer Cable Drawing w/ MS-8W ...	P-8
B1161 Rev. B	AutoTech SAC-RL210-G128 Transducer Cable Drawing	P-9
B1192	AutoTech SAC-RL210-G128 Transducer Cable Drawing w/ MS-8W ...	P-10

1.0 OBJECTIVE

The objective of this manual is to explain the installation, operation, programming, and servicing of the Series 1461/2 Absolute Resolver Encoder Modules for the Square D Sy/Max Series I/O Rack. It is strongly recommended that you read through the following instructions. If there are any unanswered questions after reading this manual, contact the factory. An applications engineer will be available to assist you.

2.0 INTRODUCTION

The 1461 Absolute Resolver Encoder Module is a single axis multi-turn module and the Series 1462 Absolute Resolver Encoder Module is a dual axis multi-turn module. Both modules plug directly into any Square D Sy/Max Register slot. Each module occupies only one slot in the rack. No external wiring is needed to interface the module to the PC. The only wiring necessary for operation is the wiring needed to connect the transducer to the module.

On the front panel, a six digit LED display and sealed keyboard allows the monitoring of transducer position and speed. Scale Factor, Offsets, and Tachometer Response are programmable from the keyboard. Each module is equipped with hardware fault and broken wire indication. Position and Tachometer information for all of the module's axes is available to the programmable controller.

3.0 SERIES 1400 FAMILY

The following table lists the model numbers of the ten different Absolute Resolver Encoder Modules presently available in the Series 1400 Family as well as a brief description of each module.

1431	10 bit, one axis, single turn encoder
1432	10 bit, two axes, single turn encoder
1433	10 bit, three axes, single turn encoder
1434	10 bit, four axes, single turn encoder
1441	13 bit, one axis, single turn encoder
1442	13 bit, two axes, single turn encoder
1443	13 bit, three axes, single turn encoder
1444	13 bit, four axes, single turn encoder
1461	18 bit, one axis, multi-turn encoder
1462	18 bit, two axes, multi-turn encoder

This manual will deal with the programming and operation of the 1461/2 modules. For instructions on the other modules, refer to the Series 1400 User's Manual.

4.0 INSTALLATION

4.1 POWER REQUIREMENTS

A Series 1460 Absolute Resolver Encoder Module draws its systems power from the I/O Rack backplane. The power that is drawn from the I/O Rack backplane is 850 mAmps from the +5 Vdc Supply (4.25 W total). Add this to the power requirements of all other cards in the rack to avoid exceeding backplane or supply capacity.

4.2 INSTALLING THE MODULE

WARNING: Remove the system power before removing or installing a module in the I/O rack. Failure to observe this warning can result in damage to the module's circuitry and/or undesired operation with possible injury to personnel.

CAUTION: The Grounding Screw on the bottom of the module must be screwed into the rack tightly in order to insure safe and proper operation.

The Series 1400 Modules can be installed in any available Register Slot in a Square D I/O Rack. These I/O Racks are the Square D register rack (8030 RRR except the first slot) or the register slot of the Square D digital I/O racks (8030 CRK, DRK, GRK, or HRK). The number of registers that must be assigned to the slot is dependent on the type of module that is installed. Refer to Section 9 Addressing the 1400 Module for more information.

The following Keying Pins should be installed in the register slot connector that the Series 1400 Module will reside in. This will insure that only an AMCI Series 1400 Module can be plugged into the slot.

Keying Pin 1: Between slot (03-04) and slot (05-06)
Keying Pin 2: Between slot (29-30) and slot (31-32)
Keying Pin 3: Between slot (91-92) and slot (93-94)

Keying Pins 1 and 3 are standard pins that are used to insure that only register modules can be plugged into the connector. Keying Pin 2 is the pin that keys the connector to accept a Series 1400 Module only.

4.3 INSTALLING THE TRANSDUCER CABLE

The transducer cable is used to carry the low-power position signals from the transducer to the module. Because these signals are low-power, they are sensitive to EMI Noise that can be generated by high power lines and devices. If Noise is injected into the Transducer Cable from outside devices, the module's transducer fault detection may be tripped. To prevent EMI Noise from being induced into the cable, the cable must be placed in a shielded conduit away from any high power lines or devices and the cable itself must incorporate a shield. If you are manufacturing your own transducer cable, the prints given at the end of this manual must be followed. Note that the cable shield is connected at the module's end and not at the transducer connectors. This is to avoid ground loops that may cause damage to the module.

4.0 INSTALLATION (cont'd)

4.3 INSTALLING THE TRANSDUCER CABLE (cont'd)

The transducer cable consists of twisted pairs of individually shielded wire. The recommended type of cable is Belden 9731 or equivalent. Advanced Micro Controls Inc. supplies Transducer cables with the following part numbers:

- CTT - (x) for the 1461 Module.
- C2TT - (x) for the 1462 Module.
- (x) is the length of the cable in feet.

5.0 FUNCTIONAL DESCRIPTION

The following sections describe the functions and programmable parameters available on the Series 1461/2 Modules. For information on programming the parameters, please refer to Section 8.0 "PROGRAMMING THE 1461/2 ABSOLUTE RESOLVER ENCODER MODULES".

5.1 FRONT PANEL DESCRIPTION:

STATUS DISPLAY

The three LED's show the status of the module including:
PROGRAM Mode.
RUN Mode.
FAULT Indication.

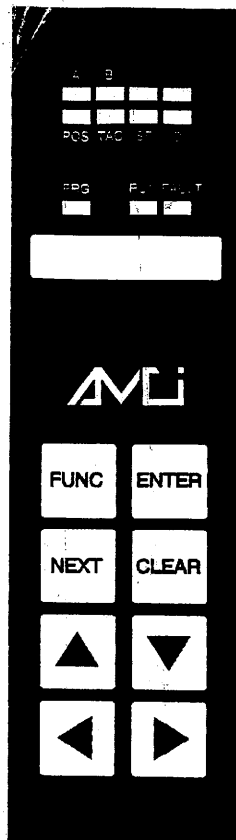

FUNCTION DISPLAY

The eight LEDs above the display are the FUNCTION INDICATORS. A blinking digit on the display denotes the CURSOR.

KEYBOARD

Used to display or modify the 1461/2 functions and parameters.

5.0 FUNCTIONAL DESCRIPTION (cont'd)

5.2 FUNCTION INDICATORS:

Above the digital display are eight LED indicators that define the function or parameter showing on the display. The Function Indicators shown below are for the first transducer. With the 1762, the "D" LED is also "ON" for the functions and parameters of the second transducer.

	LEDs ON	FUNCTION
#	POS	Transducer's Shaft Position Function.
#	TAC	Tachometer Function. (speed of rotation)
*	C	Transducer Type. (100 or 180 turn)
*	SF + A	Full Scale Number of Turns Parameter
*	SF + B	Full Scale Count Parameter (Maximum = Number of Turns * 1024)
	SF + C	Calculated Counts per Turn (Full Scale Counts / Number of Turns)
*	O + A	Circular Position Offset Parameter
*	O + B	Linear Position Offset Parameter
*	A	Decimal Point Parameter. Effects the POSITION DISPLAY only, not the PC data.

The Position and Tachometer data is available to the PC.

* These are programmable parameters that effect the Position and Tachometer Functions.

5.3 FUNCTION AND PARAMETER DESCRIPTIONS

This section describes the functions and parameters available with the 1461/2 Modules. For programming information, refer to Section 8.0: "PROGRAMMING THE 1461/2 ABSOLUTE RESOLVER ENCODER MODULES".

5.3.1 POSITION FUNCTION:

This function is the current position of the transducer's shaft. This function is affected by four programmable parameters, the Scale Factor parameters, (Number of Turns and Full Scale Count), the Circular Offset parameter, and the Linear Offset parameter. The Position data is available to the PC.

5.0 FUNCTIONAL DESCRIPTION (cont'd)

5.3 FUNCTION AND PARAMETER DESCRIPTIONS (cont'd)

5.3.2 TACHOMETER FUNCTION:

The Tachometer Function is the speed of rotation of the transducer's shaft in RPM, Revolutions Per Minute. The tachometer response time is set to 32 mSecs. The response time is the time it takes to determine a new speed and show it on the display. The Tachometer Data is available to the PC.

5.3.3 TRANSDUCER TYPE PARAMETER:

This parameter allows the module to be configured to use an HTT-20-100 One hundred turn transducer or an HTT-20-180 One hundred eighty turn transducer. This parameter also effects the Scale Factor parameters.

5.3.4 SCALE FACTOR PARAMETERS:

SF+A Full Scale Number of Turns parameter.

This parameter sets the number of turns of the transducers shaft needed to achieve the Full Scale Count. The allowable values that can be programmed into this parameter depend on the type of transducer used. For a 100 turn transducer the allowable values are 1, 2, 4, 5, 10, 20, 25, 50, or 100 turns. For a 180 turn transducer the allowable values are 1, 2, 3, 4, 5, 6, 9, 10, 12, 15, 18, 20, 30, 36, 45, 60, 90, or 180 turns.

SF+B Full Scale Count Parameter.

This parameter sets the number of Counts over the specified number of turns. When a number of turns is specified, this parameter defaults to its maximum value of 1024 Counts per turn (10 bit resolution per turn).

SF+C Calculated Counts per Turn.

This display shows the calculated number of Counts per Turn and is shown for reference only. To change the number of counts per turn, the Number of Turns and/or the Full Scale Count parameters must be changed.

When the user enters new values for the Scale Factor parameters, the Circular Offset, and Linear Offset, and Decimal Point parameters are reset to zero.

5.0 FUNCTIONAL DESCRIPTION (cont'd)

5.3 FUNCTION AND PARAMETER DESCRIPTIONS (cont'd)

5.3.5 CIRCULAR OFFSET PARAMETER

The Circular Offset parameter allows the user to change the displayed position of the transducer's shaft without changing the RANGE of values that the unit displays and sends to the PC. This offset is most commonly used to force the position to the correct count after the machine has been aligned. For example: A Module, configured to use an HTT-20-100, has a Full Scale Count of 50,000 over 50 turns. When the machine is aligned the position function should have a value of 25,000. However, the position reads 37,050. An Offset parameter must be programmed to force the position to 25,000. The formula for determining the Offset is:

$$\begin{array}{r r r r r r r r} \text{Full Scale Count} & - & \text{Actual Position} & + & \text{Desired Position} & = & \text{OFFSET} & \\ 50,000 & - & 37,050 & + & 25,000 & = & 37,950 & \end{array}$$

The maximum value of this Offset is: (Full Scale Count - 1).

If the Calculated Offset is greater than the Full Scale Counts, The Actual Offset equals (Calculated Offset - Full Scale Counts).

If the user wishes to force the position to zero, the user can use the AUTO ZERO function. This function performs all the calculations needed to determine the needed Circular Offset and stores this value in EEPROM memory. To use the AUTO ZERO Function, the user must be displaying the Position function (POS LED on). When the user presses the [CLEAR] key the unit calculates and stores the required offset. The calculated Circular Offset can then be shown on the Circular Offset display.

When the user enters new values for the Scale Factor parameters, the Circular Offset parameter is reset to zero.

5.3.6 LINEAR OFFSET PARAMETER

The Linear Offset parameter is used to change the RANGE of position values that the unit displays and sends to the PC. For example: If the Full Scale Count equals 50,000 over 50 turns and the Linear Offset Parameter equals 0, the range of position values will be 0 to 50,000. If the Linear Offset is changed to 10,000 the range of position values will be 10,000 to 60,000. The maximum value for the Linear Offset parameter is equal to (999,999 - programmed Full Scale Counts).

When the user enters new values for the Scale Factor parameters, the Circular Offset parameter is reset to zero.

5.0 FUNCTIONAL DESCRIPTION (cont'd)

5.3 FUNCTION AND PARAMETER DESCRIPTIONS (cont'd)

5.3.7 DECIMAL POINT PARAMETER

This parameter will force the display to show a decimal point when displaying the Position Function. The value of the Decimal Point parameter sets the number of digits to the right of the decimal point. For example, if the Decimal Point parameter is set to 3, and the position data equals 25000, it will be shown as 25.000 on the Function Display. This parameter is set to zero when the Scale Factor parameters are changed. This parameter does not affect the position data that is transmitted to the PC.

5.4 FAULT DIAGNOSTICS

Three single LED indicators below the digital display are used for Status indicators.

RUN: A blinking green LED indicates that the module is powered and functioning.

FAULT: A red LED lights when one of the following faults is detected:

Transducer Fault is indicated by "X_Err.1" on the digital display, if the selected function is POS or TAC. The "X" is the number of the axis that has the fault. A broken or improperly wired transducer cable or a damaged transducer will cause this fault. Another potential cause of this fault is excessive amounts of EMI Noise that is induced into the transducer cable by an external source. A flashing "X_Err.1" on the digital display indicated that the fault can be cleared by using the [CLEAR] key on the keyboard.

EEPROM Memory Fault is indicated by "Err2" on the digital display. This message is displayed regardless of the function selected. This fault, indicating corrupted data stored in the Users Program, means that the programmed parameters may be incorrect. The user can recover from this fault by pressing the [CLEAR] key. All parameters will be set to their default values. If the "Err.2" message remains on the display after the [CLEAR] Key has been pressed, this indicates a program storage failure and the module must be returned for repairs.

PRG: A lit yellow LED indicates that the module is in Program Mode. While in Program Mode, all of the Programmable Parameters can be inspected and altered.

6.0 PROGRAM MODE

WARNING: Remove the system power before removing or installing a module in the I/O rack. Failure to observe this warning can result in damage to the module's circuitry and/or undesired operation with possible injury to personnel. Please refer to Section 4.0 INSTALLATION for additional information.

A slide switch (SW1) is located on the upper part of the module's PC Board behind the display. Placing the switch in the "ON" position, (pushed towards the front of the unit), will put the 1461/2 Module in Program Mode and light the yellow LED. Removing the two pin header that is next to SW1 will disable Program Mode regardless of the position of SW1. While in Program Mode all of the Programmable Parameters can be changed.

The Programmable Parameters are:

- Transducer Type.
- Full Scale Number of Turns.
- Full Scale Count.
- Circular Offset.
- Linear Offset.

The uses of these parameters and the keystrokes needed to program these parameters are explained in Section 8.0 "PROGRAMMING THE 1461/2 ABSOLUTE RESOLVER ENCODER MODULES".

7.0 KEYBOARD DESCRIPTION

7.1 DISPLAY MODE of operation:

The Program Mode Switch (SW1) in the "off" position.
(Pushed towards the back of the unit.)

This Mode of operation allows the user to inspect all of the present values in the parameters but does not allow the changing of programmed values.

KEY	COMMENTS
[FUNCTION], [◀], [▶]	These keys are used to select the function shown on the digital display. The function displayed is determined by the Function Indicators. See Section 5.1 FUNCTION INDICATORS.
[NEXT]	This key is used to switch between axes on the 1462 module.
[CLEAR]	This key is used to recover from fault conditions. The nature of the error is determined by the message on the display See Section 5.3 FAULT DIAGNOSTICS.
[ENTER], [▲], [▼]	These keys are not used in Display Mode.

7.0 KEYBOARD DESCRIPTION (cont'd)

7.2 PROGRAM MODE of operation:

The Program Mode Switch, SW1, in the "on" position.
(Pushed towards the front of the unit.)

This mode of operation allows the user to inspect and change all of the programmable parameters.

KEY	COMMENTS
[FUNCTION]	This key is used to select the function shown on the digital display. The function displayed is determined by the Function Indicators. See Section 5.1 FUNCTION INDICATORS.
[CLEAR]	1) This key is used to recover from fault conditions. See Section 5.3 FAULT DIAGNOSTICS. 2) If the POS function is displayed, pressing this Key will AUTO ZERO the transducer. The unit will automatically calculate and store the required offset to make the Position value equal to zero.
[ENTER]	1) When pressed, this key will store the displayed data in EEPROM Memory. Only data that is displayed with a blinking cursor can be stored. When the Scale Factor is changed, the Offset will be reset to zero.
[NEXT]	This key is used to switch between axes on a multi-axes module.
[▲], [▼]	These keys are used to increment, [▲], or decrement, [▼], the number under the blinking cursor.
[◀], [▶]	1) If the blinking cursor is active, these keys move the blinking cursor to the left or the right of the display. 2) If the blinking cursor is not active, pressing these keys selects a new function.

8.0 PROGRAMMING THE 1461/2 ABSOLUTE RESOLVER ENCODER MODULES

The following steps explain the programming of the 1461/2 Absolute Resolver Encoder Modules. In all of the following examples the Module must be in the Program Mode before the keystrokes can be entered in the given sequence. Please refer to Section 6.0 PROGRAM MODE for more information.

The following conventions are used when describing the Keystrokes used to program the different functions.

[KEY]: Used to show the key pressed on the module. The key's name will be inside the brackets. If an asterisk appears before a key, (Example: *[FUNCTION]), the key must be pressed until the display is showing the proper function. If a "X" and a number follow a key, (Example: [▲]X3), the key must be pressed the shown number of times. (In this example, the [▲] key would be pressed 3 times.

"Display": Information shown on the 6 digit display. A blinking cursor is shown by a underline.

IND1 + IND2: Indicator LEDs that indicate the parameter or function being programmed or displayed.

The following keystroke examples use the least number of keystrokes. However, any series of keystrokes is valid as long as the data is correct before the [ENTER] key is pressed.

The following programming examples use the parameters for the first axis only. The examples are equally valid for the second axis of a 1462 Module. The only change is that the [NEXT] key must first be pressed to switch to the second axis. The first and second axes of the 1462 are distinguished by the "D" Indicator Light. This light is ON when the displayed functions and parameters are for the second axis.

8.1 TRANSDUCER TYPE PARAMETER:

You want to use the HTT-20-100 One hundred turn Transducer with the Module. The Module is presently configured for the HTT-20-180 One hundred eighty turn Transducer.

PRESS	IND. LEDS	DISPLAY	COMMENTS
*[FUNCTION]	C	" <u>180</u> "	180 turn Transducer Type
[▲]	C	" <u>100</u> "	100 turn Transducer Type
[ENTER]	C	" 100 "	New Transducer Type entered.

8.0 PROGRAMMING THE 1461/2 ABSOLUTE RESOLVER ENCODER MODULES (cont'd)

8.2 SCALE FACTOR PARAMETERS:

You want to program a Full Scale Number of Turns of 50 and a Full Scale count of 50,000. Presently, the Full Scale Number of Turns is programmed to 100.

PRESS	IND. LEDS	DISPLAY	COMMENTS
*[FUNCTION]	SF + A	" <u>1</u> 00"	Present Number of Turns.
[▼], [▶] [▲]X5,	SF + A	" 0 <u>5</u> 0"	Desired Number of Turns.
[ENTER]	SF + A	" 050"	Value stored in EEPROM Blinking cursor removed.
[FUNCTION]	SF + B	" <u>0</u> 51200"	Default Full Scale Count. (50 * 1024 = 51200)
[▶]X2, [▼], [▶], [▼]X2, [ENTER]	SF + B	"050000"	Programmed Full Scale Count.
[NEXT]	SF + C	"1000.00"	Calculated counts per Turn.

8.3 CIRCULAR OFFSET PARAMETER:

You want to program in a Circular Offset of 700 counts. The default value of 000000 is presently in memory.

PRESS	IND. LEDS	DISPLAY	COMMENTS
*[FUNCTION]	OF + A	"000000"	Present Offset.
[▶]X3, [▼]X3	OF + A	"000 <u>7</u> 00"	Desired Offset.
[ENTER]	OF + A	"000700"	Value stored in EEPROM Blinking cursor removed.

8.0 PROGRAMMING THE 1461/2 ABSOLUTE RESOLVER ENCODER MODULES (cont'd)

8.4 AUTO ZERO:

The machine is at mechanical zero. You want to preset the transducers position to 000000. Instead of calculating the required offset, the operator uses the Auto Zero function.

PRESS	IND. LEDS	DISPLAY	COMMENTS
*[FUNCTION]	POS	"xxxxxx"	xxxxxx = Present Position.
[CLEAR]	POS	"000000"	Position reset to zero.
*[FUNCTION]	OF + A	"yyyyyy"	yyyyyy = Calculated Offset.

8.5 LINEAR OFFSET PARAMETER:

You want to program in a Linear Offset of 1000 counts. The default value of 000000 is presently in memory.

PRESS	IND. LEDS	DISPLAY	COMMENTS
*[FUNCTION]	OF + B	"000000"	Default Linear Offset
[▶]X2, [▲] [ENTER]	OF + B	"001000"	Value Stored in EEPROM. Blinking Cursor removed.

8.6 DECIMAL POINT PARAMETER:

You want to program a decimal point so that the last three digits are after it. The parameter presently has its default setting of 0 (no decimal point).

PRESS	IND. LEDS	DISPLAY	COMMENTS
*[FUNCTION]	POS	"012345"	Present Position
	A	"dP 0"	No Decimal Point on the Position Display
[▲]X3, [ENTER]	A	"dP 3"	Programmed value.
*[FUNCTION]	POS	"012.345"	Three digits to right of Decimal Point

9.0 ADDRESSING THE 1461/2 MODULE

Before a Series 1461/2 Module can communicate with a Square D programmable controller, you must assign register numbers to the slot that the module is plugged into. The number of registers that must be assigned to the slot is dependent on the type of 1400 Module. The following table lists the ten 1400 Modules and the required number of registers.

Module Number	# of Registers
1431/41	2
1432/42	4
1433/43	6
1434/44	8
1461	3
1462	6

The process of assigning register numbers to the slots is called RACK ADDRESSING. Rack Addressing is accomplished from your CRT Programmer. The actual steps involved in Rack Addressing are different for each model of Square D processors. Please refer to the appropriate instruction bulletin for each type of SY/MAX programmer.

The Series 1400 Modules appear as INput modules to the SY/MAX controller. When the Rack addresses are specified on the CRT Programmer, using the CPU or REMOTE RACK ADDRESS ASSIGNMENT Displays, the "MODULE INFO" comment should read "IN D5" if the module is operating correctly. "D5" is the hexadecimal code specified by Square D for third party Input Modules.

10.0 1460 MODULE REGISTER DATA FORMAT

Up to six registers are used by the Series 1460 Modules to communicate Position and Tachometer data to the SY/MAX Processor. All data values are in Binary. The maximum Position Value equals 999,999 when the Linear Offset is used. This translates into 20 bits of information in binary format. Because of this, the position data is transferred in two words. The most significant 5 bits are stored in word 1, the least significant 15 bits in word 2. If your position values do not exceed 32,767 the position data will be in word 2 only, word 1 will always equal zero.

BIT	16	15	14	13	12	11	10	09	08	07	06	05	04	03	02	01
REG. 1	E*	0	0	0	0	0	0	0	0	0	0	See Note 1				
REG. 2	E*	Least Significant 15 bits Pos Data TRANS. 1														
REG. 3	E*	0	0	0	0	11 Bit Tachometer Value TRANS. 1										
REG. 4	E*	0	0	0	0	0	0	0	0	0	0	See Note 1				
REG. 5	E*	Least Significant 15 bits Pos Data TRANS. 2														
REG. 6	E*	0	0	0	0	11 Bit Tachometer Value TRANS. 2										

NOTES

- 1) Registers 1 and 4 contain the most significant 5 bits of position data for either Transducer 1 or 2.
- 2) Because both the Position and Tachometer data is less than 16 bits in length, both have preceding zero's to complete the 16 bit register.
- 3) When a transducer fault is detected, the module will transmit 8000h (Bit 16 set) in the words of the effected channel. For example, if transducer 2 has a fault, 8000h will be transmitted in words 4, 5, and 6. When a E²PROM error is detected, 8000h (Bit 16 set) will be transmitted in all of the words sent to the processor. For more information on Fault conditions, refer to 5.3 FAULT DIAGNOSTICS, Pg 7.

11.0 SPECIFICATIONS:

Module Location

Any SY/MAX[®] Register Slot

Position Transducer

AMCI Brushless Resolver

Transducer Input

Transformer Isolated

Position Resolution

143x: Programmable to 1 part in 1024

144x: Programmable to 1 part in 8192

1461/2: Programmable to 1 part in 1024 per turn

1463: Programmable to 1 part in 1024 per turn (10,000,000 Counts max.)

New Position Throughput Time

400 uSec: 1431, 32, 41, 42, 61

800 uSec: 1433, 34, 43, 44, 62, 63

Programmable Parameters

Scale Factor (Full Scale Counts)

Number of Turns (146x only)

Decimal Point Position (146x only)

Circular Offset

Linear Offset

Tachometer Response time (143x/4x only)

Tachometer Resolution (143x/4x only)

Number of Turns (146x only)

1461/2:

100 Turn Transducer:

1, 2, 4, 5, 10, 20, 25, 50, or 100 turns

180 Turn Transducer:

1, 2, 3, 4, 5, 6, 9, 10, 12, 15, 18, 20, 30, 36, 45, 60, 90, or 180 turns

1463:

10,000 Turn Transducer:

200, 400, 500, 1000, 2000, 2500, 5000, or 10000 turns

Position Offset

Circular Offset programmable from 0 to Full Scale Count

Linear Offset programmable from 0 to:
(9999 - Full Scale Count) 143x, 144x
(999999 - Full Scale Count) 1461/2
(9999999 - Full Scale Count) 1463

Programmable Tachometer Response Time

32, 60, 120, or 240 mSec: (143x/4x only)

Set to 32 mSec: (146x)

Tachometer Resolution

1 RPM at 32, 60, or 120 mSec response times

Programmable to 1 RPM or 0.1 RPM at 240 mSec response time

Tachometer Range

1 to 2000 RPM at 32, 60, and 120 mSec response time

1 to 1000 or 0.1 to 999.9 at 240 mSec response time

Data Available to Processor

Transducer's Shaft Position, Shaft Velocity, and Fault Diagnostics

Program Input

Module's self-contained keyboard and display

Program Storage

EEPROM Memory

DC Supply Voltage from Backplane

+ 5 Volts @ 0.95A max. (4 axis Module)

Module's +5V DC Supply Fuse

1.5A Fast Blow (Littelfuse 22501.5)

Environmental Conditions

Operating Temperature: 0 to 60° C.

Relative Humidity: 5 to 95%
(without condensation)

Storage Temperature: -40 to 85° C.

Connector Keying

Pin 1: Between slot (03 - 04) and slot (05 - 06)

Pin 2: Between slot (29 - 30) and slot (31 - 32)

Pin 3: Between slot (91 - 92) and slot (93 - 94)

The 1461 and 1462 are now compatible with Autotech RL-210 Series transducers. These modules allow you to use an Autotech RL-210 transducer as the resolver input. You can select either an AMCI transducer or an Autotech transducer from the keyboard.

When the 1461 is setup to interface with the Autotech RL-210, the Full Scale Number of Turns can be programmed to any of the following numbers: 1, 2, 4, 8, 16, 32, 64 or 128.

Input Transducer Selection

Because of the differences in the design of the AMCI and Autotech transducers, an additional parameter has been added that must be programmed from the keyboard. The following keystrokes are used to switch between an AMCI and an Autotech transducer.

PRESS	IND. LEDS	DISPLAY	COMMENTS
*[FUNCTION]	POS + A	"rES 1"	Default Value, AMCI transducer.
[▲], [ENTER]	POS + A	"rES 2"	Autotech selected, Value stored in E ² PROM. Blinking Cursor removed.

Autotech Transducer Hookup

If the modules' part number has an 'A' at the end of it, the module directly supports Autotech transducers instead of AMCI transducers. If the part number does not end in 'A' then a Reference Module, AMCI Part Number RM-3, must be used when hooking up the Autotech transducer.

The diagram below shows how to install an RM-3 into any of the Autotech cable prints given in the back of the manual.

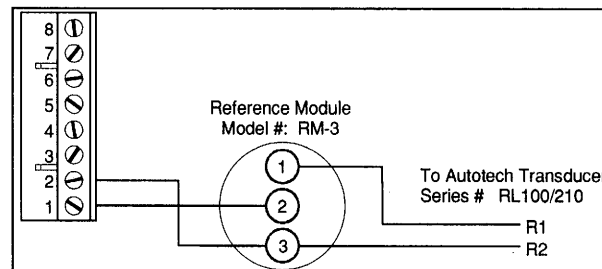

Fig A-1. RM-3 Installation

Appendix A: Additional Instructions

Notes:

Along with the extra features offered on the 1461 modules, (See Appendix A), the 1461-01 modules offer remote display capability. You can make connection to the remote display through a fiber optic or RS-485 compatible link.

Front Panel Description

There are two additional connectors on the front panel of the 1461-01 modules.

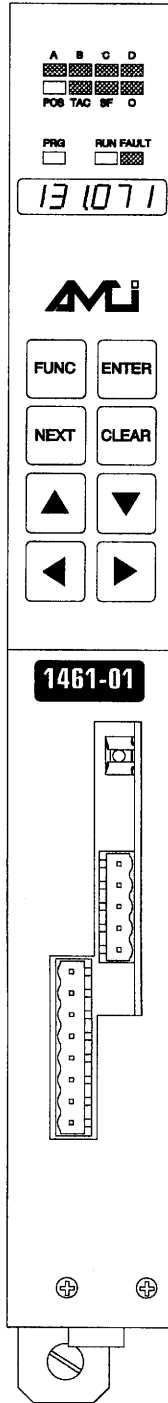

Fiber Optic Transmitter - Mates with Fiber Optic Cable, AMCI Part # CDP-(x) where (x) is length in meters. Maximum cable length is 75 meters (245 feet).

RS-485 Connector - Mates with RS-485 Cable AMCI Part # CDC-(x) where (x) is length in meters. Maximum Cable length is 300 meters (1000 feet). This RS-485 compatible link is electrically isolated and requires an external supply. **When connected to AMCI's 6100F Remote Display, the 6100F supplies the external power.**

Fig B.1 1461-01 Front Panel

Fiber Optic Cable Installation

All fiber optic cables for use with the 1461-01 Modules must be manufactured by AMCI. The part number for the fiber optic cable is CDP-(x) where (x) is the length in meters. You must not splice these cables in the field. If your installation requires a splice in the cable run, order two or more cables from AMCI of the proper lengths.

Because splices in a cable cause light loss, the number of splices in a cable run effects its maximum length. The following table lists the maximum run lengths based on the number of splices. The connections to the fiber optic transmitter and receiver are not considered splices.

Number of Splices	Maximum Cable Run Length
0	75 meters (245 feet)
1	66 meters (215 feet)
2	57 meters (185 feet)
3	48 meters (155 feet)
4	35 meters (115 feet)

Fig B.2 Maximum Fiber Optic Cable Run Lengths

Complete installation information, including splice connectors can be found in the 6100F User's Manual.

RS-485 Cable Installation

A wiring diagram of the CDC-(x) {(x) = Length in Meters}, is shown in Fig. B.3. Maximum cable length is 300 Meters (1000 Feet).

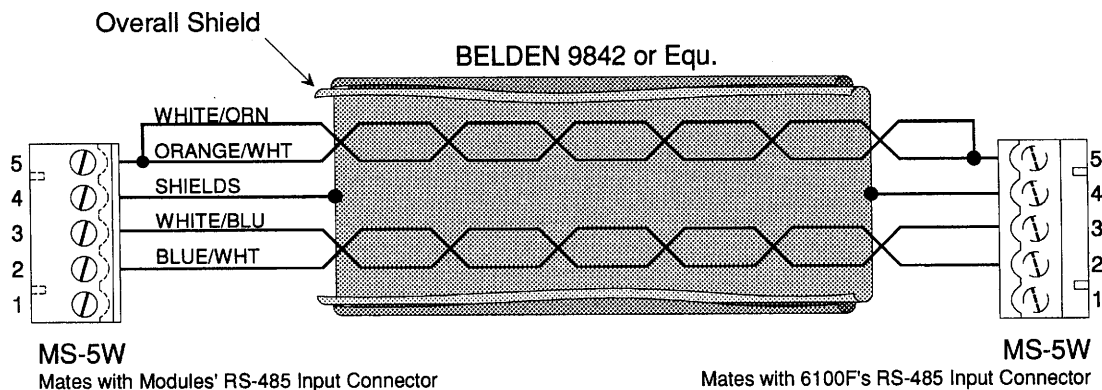

Fig B.3 CDC-(x) Wiring Diagram

If you splice the CDC-(x) Cable, it should be done in a grounded junction box. **THE SHIELD MUST BE ISOLATED FROM THE JUNCTION BOX.** If this practice is not followed, you may form a ground loop between the 6100F and the junction box that may effect the RS-485 Communications or damage the 6100F.

Additional Displays and Keyboard Programming

A 1461-01 Module has two additional parameters that you must program if you use the fiber optic communication link. These two parameters are Number of Splices and Fiber Optic Run Length. A module uses these parameters to set the power output of the fiber optic transmitter. If these two parameters are not programmed correctly, the fiber optic link may not operate. The modules also have one additional error message that is displayed if the remote display board inside the module is not communicating with the main board of the module.



Fig B.4 # of Splices

Number of Splices - Must be set to the number of splices in the fiber optic cable over the entire cable run. This parameter accepts values between 0 and 4. When this Parameter is changed, the Fiber Optic Cable length is reset to zero.

In this programming example, you change the Number of Splices to 2 from its default of 0.

PRESS	IND. LEDES	DISPLAY	COMMENTS
*[FUNCTION]	A + B	"SPL _ <u>0</u> "	Default Value.
[▲]X2, [ENTER]	A + B	"SPL _2"	Value stored in E ² PROM. Blinking Cursor removed.

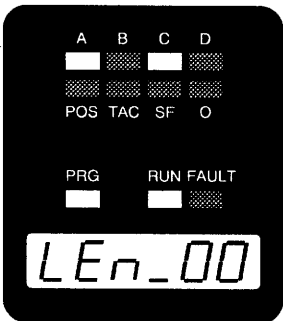

Fig B.5 FO Run Length

Fiber Optic Run Length - Must be set to the total length of cable between the 1461-01 module and the 6100F Remote Display. This parameter is programmed in meters and its maximum value depends on the number of splices. Refer to Figure B.2 Maximum Fiber Optic Cable Run Lengths, Pg B-2 for a list of maximum cable lengths. Programming a length of zero disables the fiber optic link.

Additional Displays and Keyboard Programming (cont'd)

Fiber Optic Run Length (cont'd)

In this programming example, you change the Length to 30 meters (100 feet) from its default of 0.

PRESS	IND. LEDS	DISPLAY	COMMENTS
*[FUNCTION]	A + C	"LEn _ 00"	Default Value.
[▲]X3, [ENTER]	A + B	"LEn _ 30"	Value stored in E ² PROM. Blinking Cursor removed.

Additional Error Messages

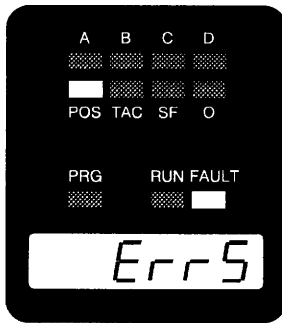

Fig B.6 RD Board Fault

Error Class 5:

Remote Display Board Fault. - Occurs when there is a communications fault between the remote display board inside the module and the modules' main board. If this error occurs, cycle power to the module. If the error message remains, the module must be returned for repairs. See inside front cover *Returns Policy*: for additional information.

Error Messages are transmitted to the 6100F and are shown on the its display. For a complete list of error messages that a 6100F displays, refer to the 6100F User's Manual.

Transducer Cable Changes

Because of the positioning of the RS-485 Input Connector on the modules' front panel, a MS-8 Connector cannot be used as the Transducer Connector. A MS-8W should be used instead. See The following prints for proper cable wiring:

- B1190 CTTW-(x) for use with AMCI HTT-20-100/180/1000/1800 Transducers
- B1191 Transducer Cable for use with Autotech SAC-RL210-G128M Transducer
- B1192 Transducer Cable for use with Autotech SAC-RL210-G128 Transducer

DATE	BY	REVISION RECORD	AUTH	DR	CK

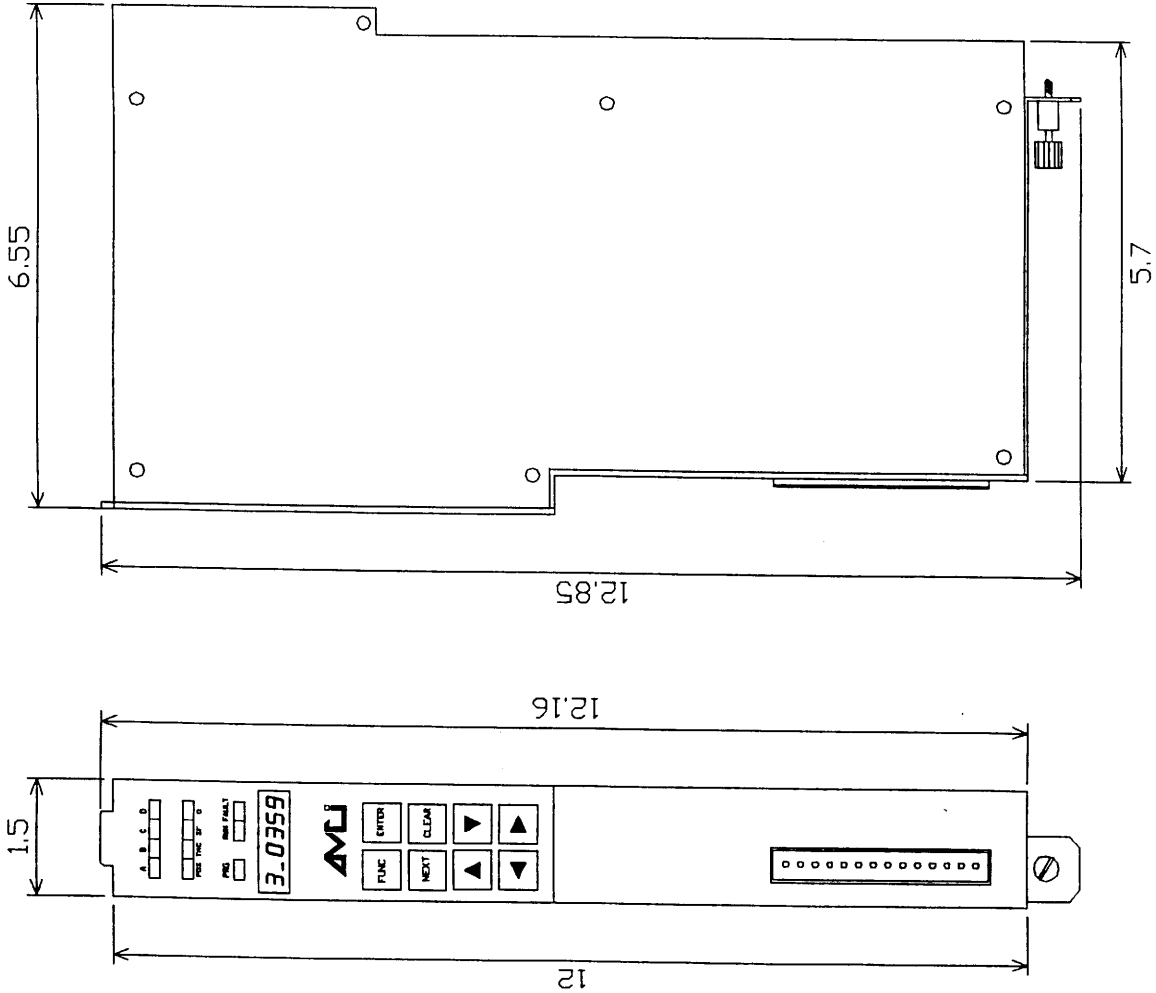

TOLERANCES (EXCEPT AS NOTED)	AMC ADVANCED MICRO CONTROLS INC.	
DECIMAL ±	SERIES 1400	SCALE NONE
FRACTIONAL ±	DRAWN BY <i>D.W.</i> APPROVED BY	
ANGULAR ±	TITLE OUTLINE DRAWING	
	DATE 5/30/91	DRAWING NUMBER B1153

MADE IN U.S.A.
K&E ALBANY, N.Y. 12004
ENGINEERS' STANDARD FORM

DATE	SYM	REVISION RECORD	AUTH	DR	CK

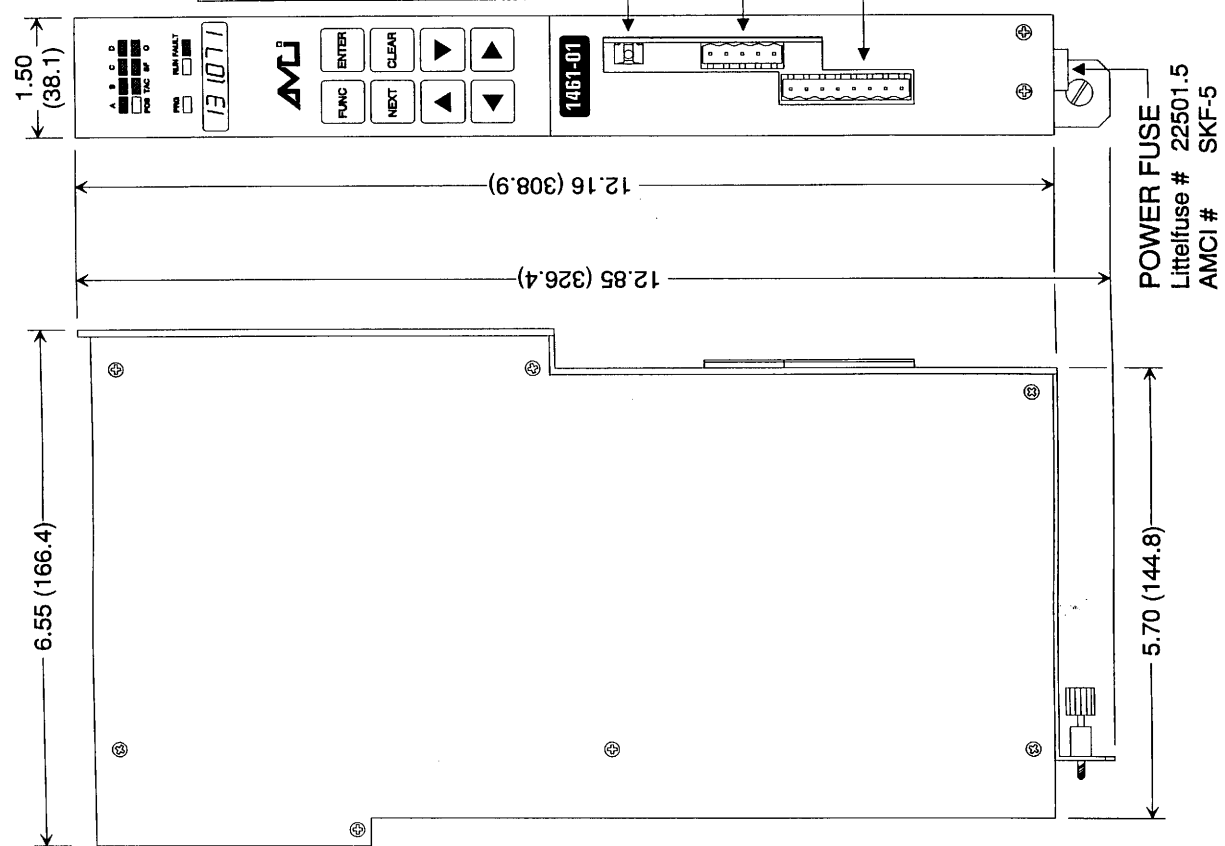

FIBER OPTIC TRANSMITTER - For use with 6100F Remote Displays.
Mates with Fiber Optic Cable AMCI # CDP-(x) where (x) is length in meters.

RS-485 CONNECTOR - For use with 6100F Remote Displays.
Mates with:
Phoenix #: MVSTBW 2.5/5-ST-5.08
AMCI #: MS-5W

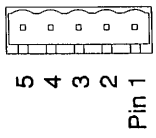

NOTE: + Vn is supplied by the 6100F Remote Display.
See Print A1083 for RS-485 Cable AMCI # CDC-(x) where (x) is length in meters.

TRANSDUCER INPUT CONNECTOR

Mates with:
Phoenix #: MVSTBW 2.5/8-ST-5.08
AMCI #: MS-8W

See the following for Cable Pin-outs:
B1190: CTTW-(x)
B1191: Connection to Autotech SAC-RL210-G128M
B1192: Connection to Autotech SAC-RL210-G128

POWER FUSE
Littelfuse # 22501.5
AMCI # SKF-5

TOLERANCES (EXCEPT AS NOTED)	AMCI ADVANCED MICRO CONTROLS INC.	
DECIMAL	SCALE	DRAWN BY
#	1461-01	DWN
FRACTIONAL	NONE	APPROVED BY
#		ER
ANGULAR	TITLE	
#	Outline and Connector Pin-out	
DATE	DRAWING NUMBER	
3/1/93	B1187	

DATE	SYM	REVISION RECORD	AUTH	DR	CK
3/93	A	Added 1460/1960 Note	DW/J		

Module Connector
 Mates with all AMCI Single Channel Multi-turn Absolute Resolver Products
 AMCI Part #: MS-8
 Phoenix #: MSTB 1.5/8-ST-5.08

→ BELDEN 9731 Cable.

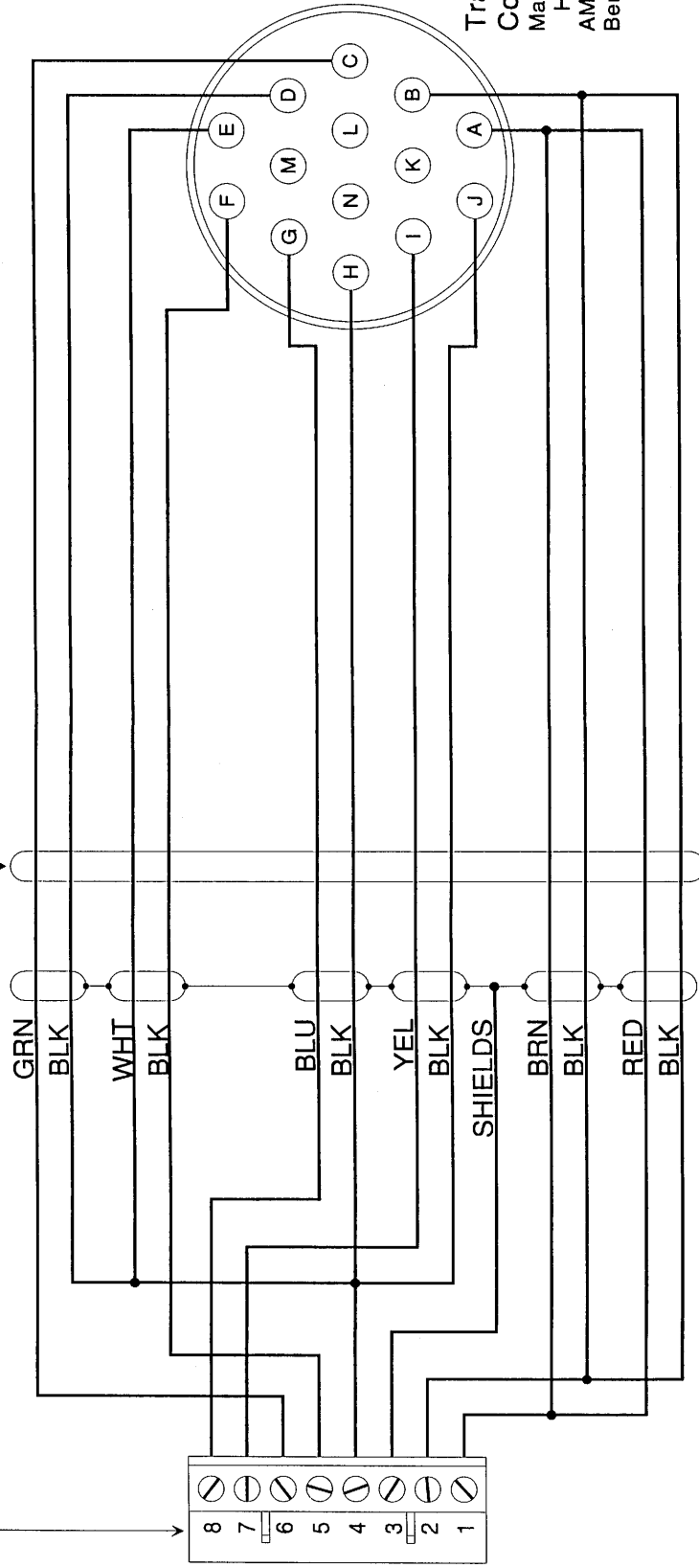

Transducer Connector
 Mates with:
 HTT-20-(x) B1016
 AMCI Part #: MS-20
 Bendix #: MS3106A20-27S

Connections are shown for CW increasing readings
 For CCW increasing readings, reverse GRN/BLK Pair (Pins C&D), and BLU/BLK Pair (Pins G&H).

1460/1960 Users:
 Pin 1 of the Transducer Input Connector is located towards the top of the module, NOT the bottom as this drawing may imply. Reversing the wires on the Module Connector will not harm the module or the transducer, but the transducer will not operate. **IF YOUR MODULE HAS THE REMOTE DISPLAY OPTION**, the cable must be a CTTW-(x). Refer to Print B1190.

TOLERANCES (EXCEPT AS NOTED)	AMCI ADVANCED MICRO CONTROLS INC.	
DECIMAL	SCALE	DRAWN BY DW/J
FRACTIONAL	None	APPROVED BY JRS
ANGULAR	TITLE Transducer Cable Drawing	
	DATE 5/23/86	DRAWING NUMBER B1040 REV. A

DATE	SYM	REVISION RECORD	AUTH	DR	CK

Module Connector
 Mates with all AMCI Single Channel Multi-turn Absolute Resolver Products
 AMCI Part #: MS-8W
 Phoenix #: MVSTBW 2.5/8-ST-5.08

→ BELDEN 9731 Cable.

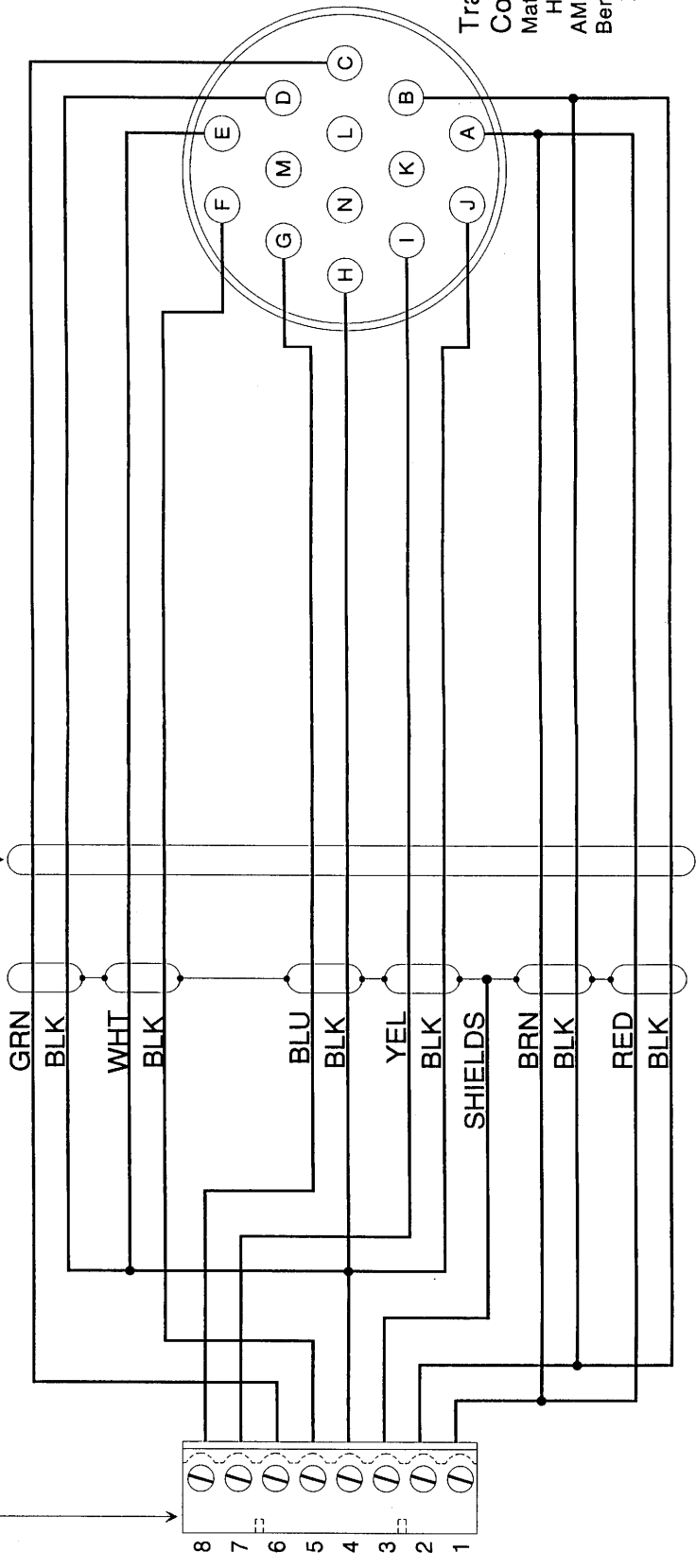

Transducer Connector
 Mates with:
 HTT-20-(x) B1016
 AMCI Part #: MS-20
 Bendix #: MS3106A20-27S

Connections are shown for CW increasing readings
 For CCW increasing readings, reverse GRN/BLK Pair (Pins C&D), and BLU/BLK Pair (Pins G&H).

1460/1960 Users:
 Pin 1 of the Transducer Input Connector is located towards the top of the module, NOT the bottom as this drawing may imply. Reversing the wires on the Module Connector will not harm the module or the transducer, but the transducer will not operate.

TOLERANCES (EXCEPT AS NOTED)	DECIMAL	AMCI ADVANCED MICRO CONTROLS INC.	
	FRACTIONAL	SCALE	DRAWN BY
±	±	None	DWN
±	±	(x) = Length in Feet	APPROVED BY
±	±		FR
TITLE		DRAWING NUMBER	
Transducer Cable Drawing		B1190	
DATE	DRAWING NUMBER		
3/9/93	B1190		

DATE	SYM	REVISION RECORD	AUTH	DR	CK

Module Connector
 Mates with all AMCI Single Channel Multi-turn Absolute Resolver Products
 AMCI Part #: MS-8W
 Phoenix #: MVSTBW 2.5/8-ST-5.08

BELDEN 9731 Cable or exact equ..

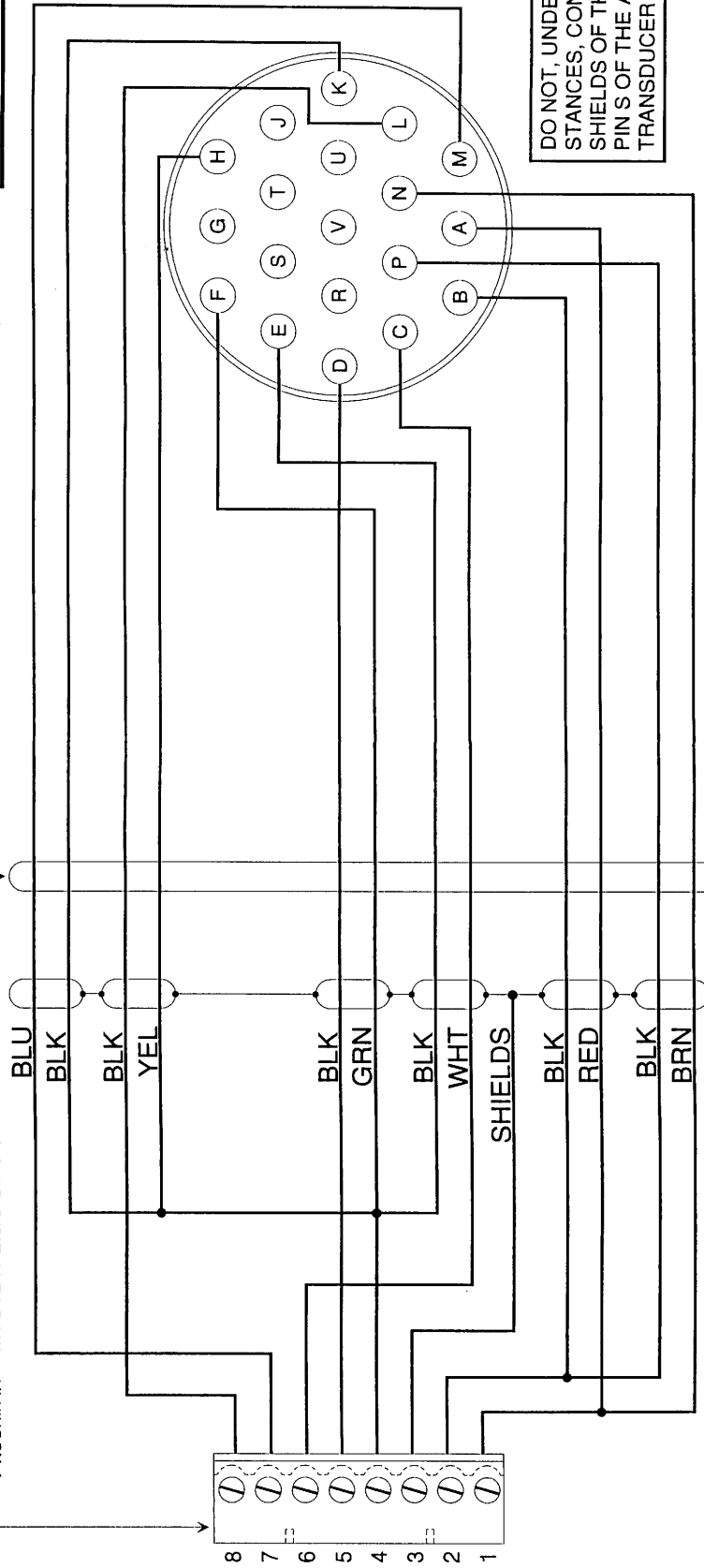

Transducer Connector
 Mates with Autotech
 SAC-RL210-G128M
 Transducer.

Connections are for CW increasing readings
 For CCW increasing readings, reverse WHIT/BLK Pair
 (Pins C&E), and YEL/BLK Pair (Pins H&L).

NOTE: This print is for use with AMCI Modules specifically designed to use the Autotech SAC-RL210-G128M Transducer. This Autotech transducer does not interface with AMCI standard product.

1460/1960 Users:

Pin 1 of the Transducer Input Connector is located towards the top of the module, NOT the bottom as this drawing may imply. Reversing the wires on the Module Connector will not harm the module or the transducer, but the transducer will not operate.

TOLERANCES (EXCEPT AS NOTED)	AMCI ADVANCED MICRO CONTROLS INC.		
DECIMAL	AUTOTECH	SCALE	DRAWN BY DW/N
FRACTIONAL	SAC-RL210-G128M	None	APPROVED BY R
ANGULAR	TITLE Transducer Cable Drawing w/ MS-8W		
	DATE 3/9/93	DRAWING NUMBER	B1191

DATE	BY	REVISION RECORD	AUTH	DR	CK
1/83	A	Added Specifications	D/W/N		

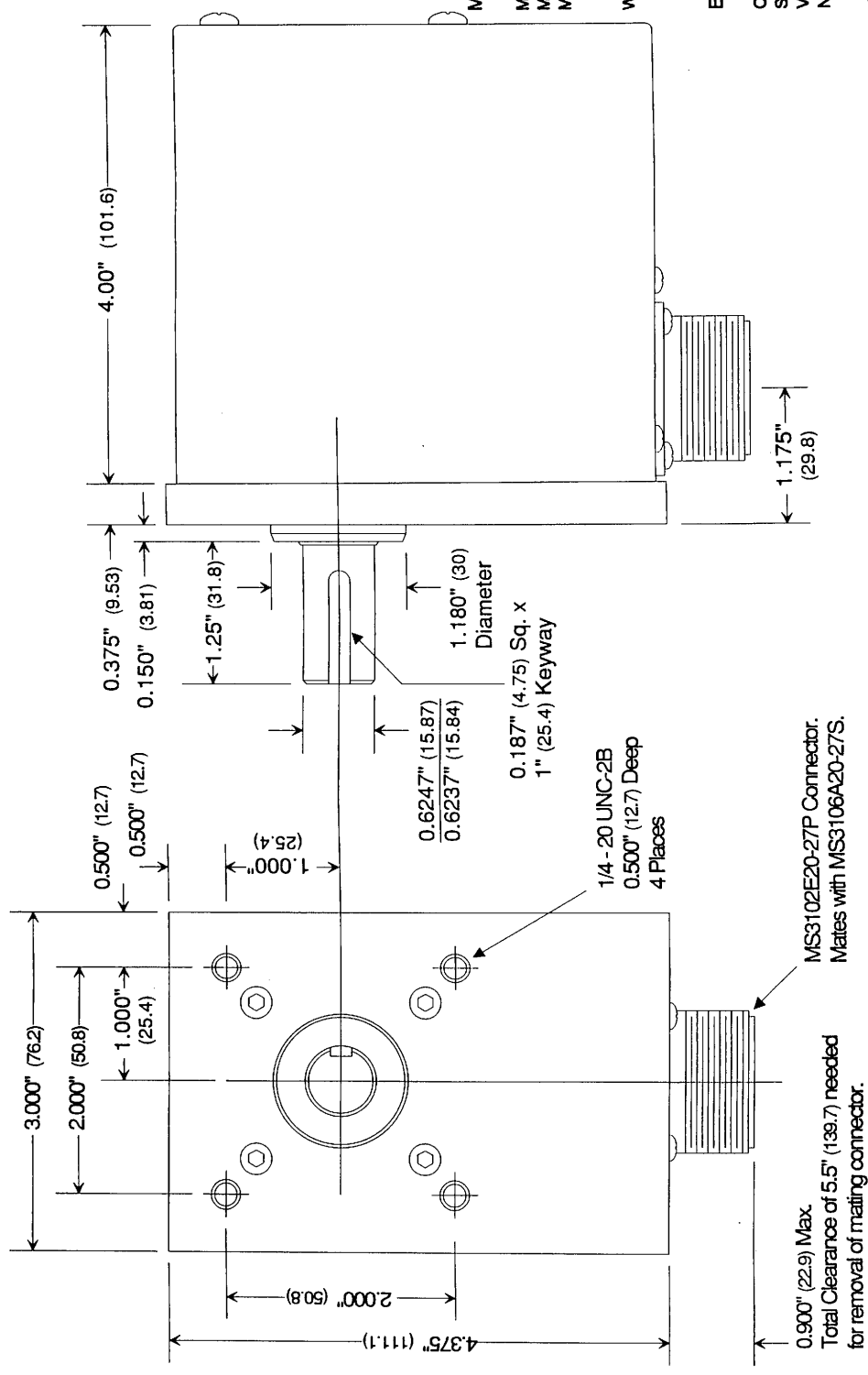

MECHANICAL SPECIFICATIONS

Max. Starting Torque @ 25°C 8 oz.in.
 Moment of Inertia 20 oz-in-sec²
 Max. Shaft Loading:
 Radial 400 lbs.
 Axial 200 lbs.
 Weight 3 lbs.

ENVIRONMENTAL SPECIFICATIONS

Operating Temperature -20 to 125°C.
 Shock 50 G's for 11 mSec.
 Vibration 5 to 2000 Hz @ 20 G's
 Nema Rating Nema 13

MS3102E20-27P Connector.
 Mates with MS3106A20-27S.
 0.900" (22.9) Max.
 Total Clearance of 5.5" (139.7) needed
 for removal of mating connector.

() = Dimensions in millimeters

TOLERANCES (EXCEPT AS NOTED)	AMC ADVANCED MICRO CONTROLS INC.		
DECIMAL	SCALE	DRAWN BY	D/W/N
FRACTIONAL	1:1	APPROVED BY	W X E
ANGULAR	TITLE		
	DRAWING NUMBER		
	DATE	B1016 REV. A	
	6/1/87		

DATE	SYM	REVISION RECORD	AUTH	DR	CK
9/89	A	Added Transducer Letters	DJS		
10/93	B	Added to: Mod. and Trans. Connect			
		Added: 14/1900 Note			
		Deleted: 2.5/5 KHz Reference	DW/N		
10/94	C	Corrected A/B Connections, Trans B/D/W/N			

Connections are shown for CW increasing readings
For CCW increasing readings, reverse GRN/BLK Pair (Pins C&D),
and BLU/BLK Pair (Pins G&H).

14/1900 Users:
Pin 1 of the Transducer Input Connector is located towards the top
of the module, NOT the bottom as this drawing may imply.
Reversing the wires on the Module Connector will not harm the
module or the transducer, but the transducer will not operate.

**Transducer B
Connector**
Mates with:
HTT-20-(X)
AMCI Part #: MS-20
Bendix #: MS3106A20-27S

**Transducer A
Connector**
Mates with:
HTT-20-(X)
AMCI Part #: MS-20
Bendix #: MS3106A20-27S

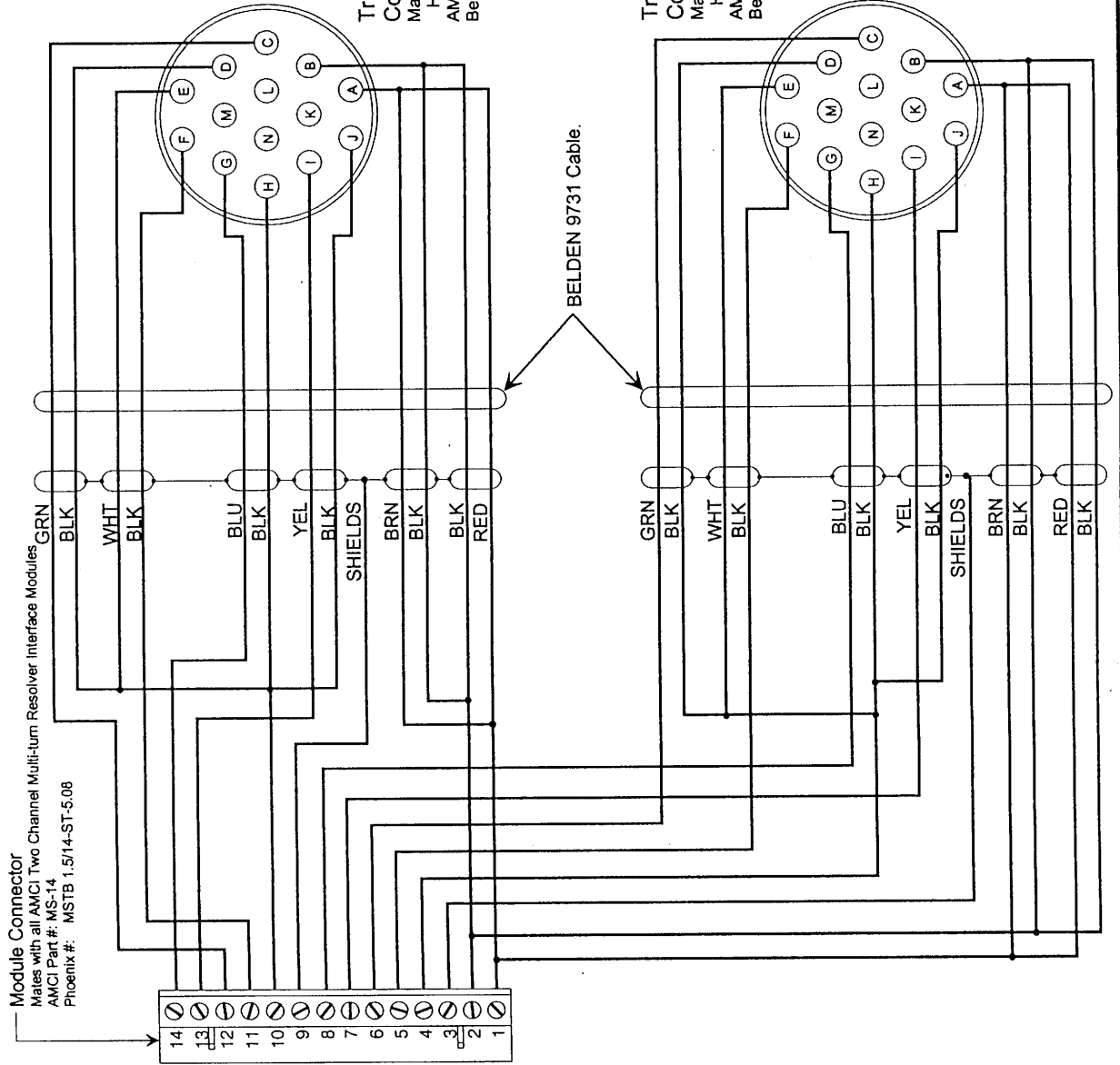

TOLERANCES (EXCEPT AS NOTED)	AMCI ADVANCED MICRO CONTROLS INC.	
DECIMAL	SCALE	DRAWN BY DW/N
FRACTIONAL	N/A	APPROVED BY DJS
ANGULAR	TITLE	
	Transducer Cable Drawing	
	DATE	DRAWING NUMBER
	8/21/89	B1091 REV. C

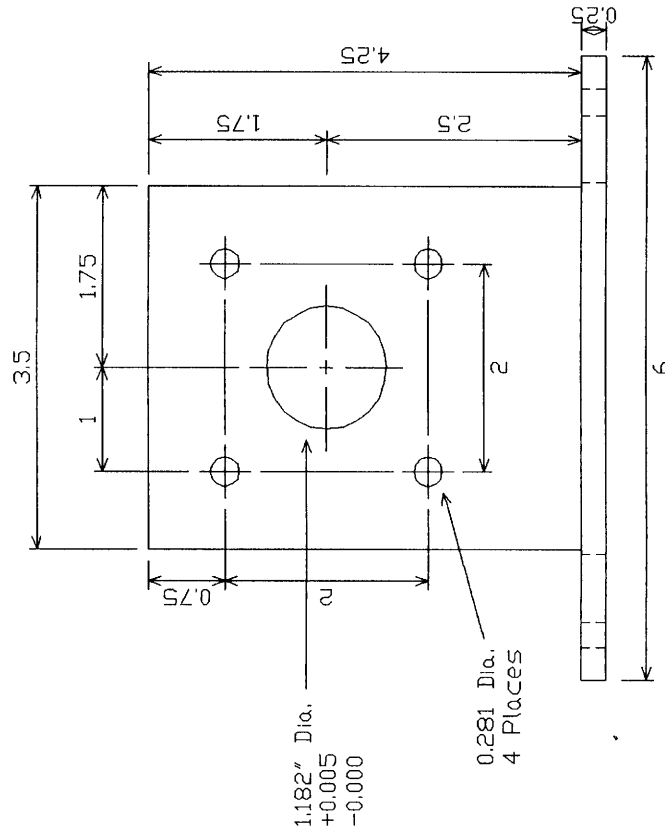
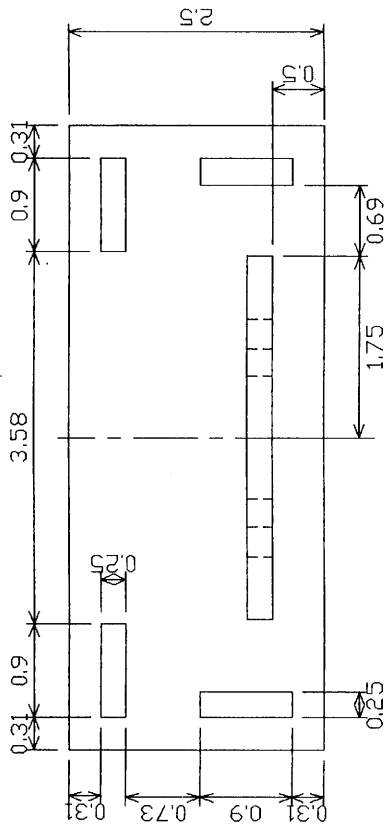

 ADVANCED MICRO CONTROLS, INC.		SCALE	DRAWN BY
22115600		HT/HTT TRANS.	DWN
TITLE		TRANSDUCER MT. BRACKET	
DATE	DRAWING NUMBER		
6/14/91	B1156		

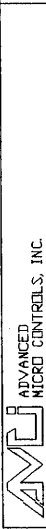
 ADVANCED MICRO CONTROLS, INC.	
22115600	SCALE
HT/HTT TRANS.	DRAWN BY <i>DWN</i>
TITLE	
HTT-20-(x) IN 22115600 MOUNTING BRACKET.	
DATE	DRAWING NUMBER
6/14/91	B1158

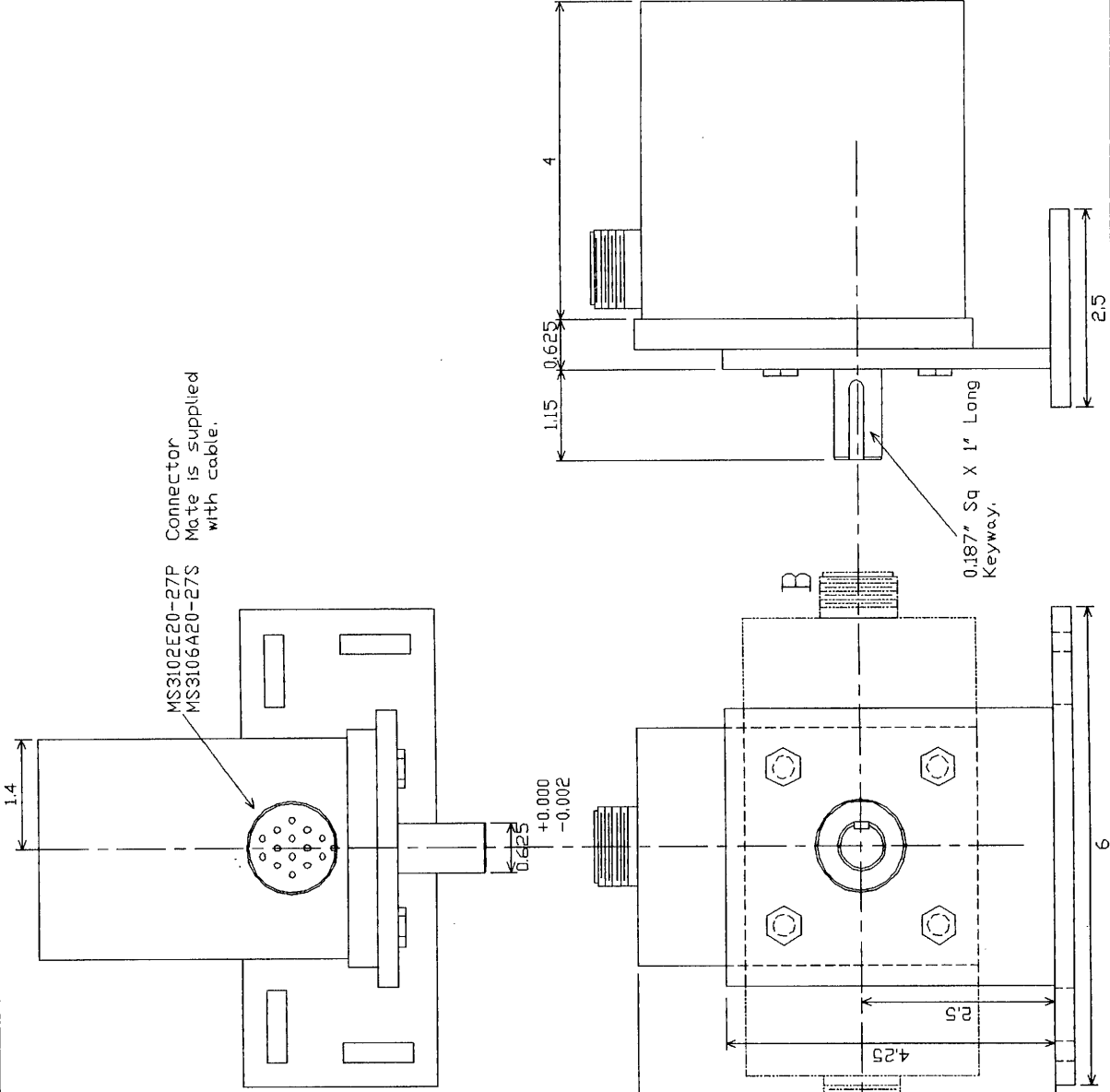

Positions (A) and (B) are alternate mounting positions.

DATE	SYM	REVISION RECORD	AUTH	DR	CK
1/53	A	Added CW/CCW Note	D/W/N		
3/53	B	Added Compatibility and 1460/1960 Note	D/W/N		

Module Connector
 Mates with all AMCI Single Channel Multi-turn Absolute Resolver Products
 AMCI Part #: MS-8
 Phoenix #: MSTB 1.5/8-ST-5.08

→ BELDEN 9731 Cable or exact equ..

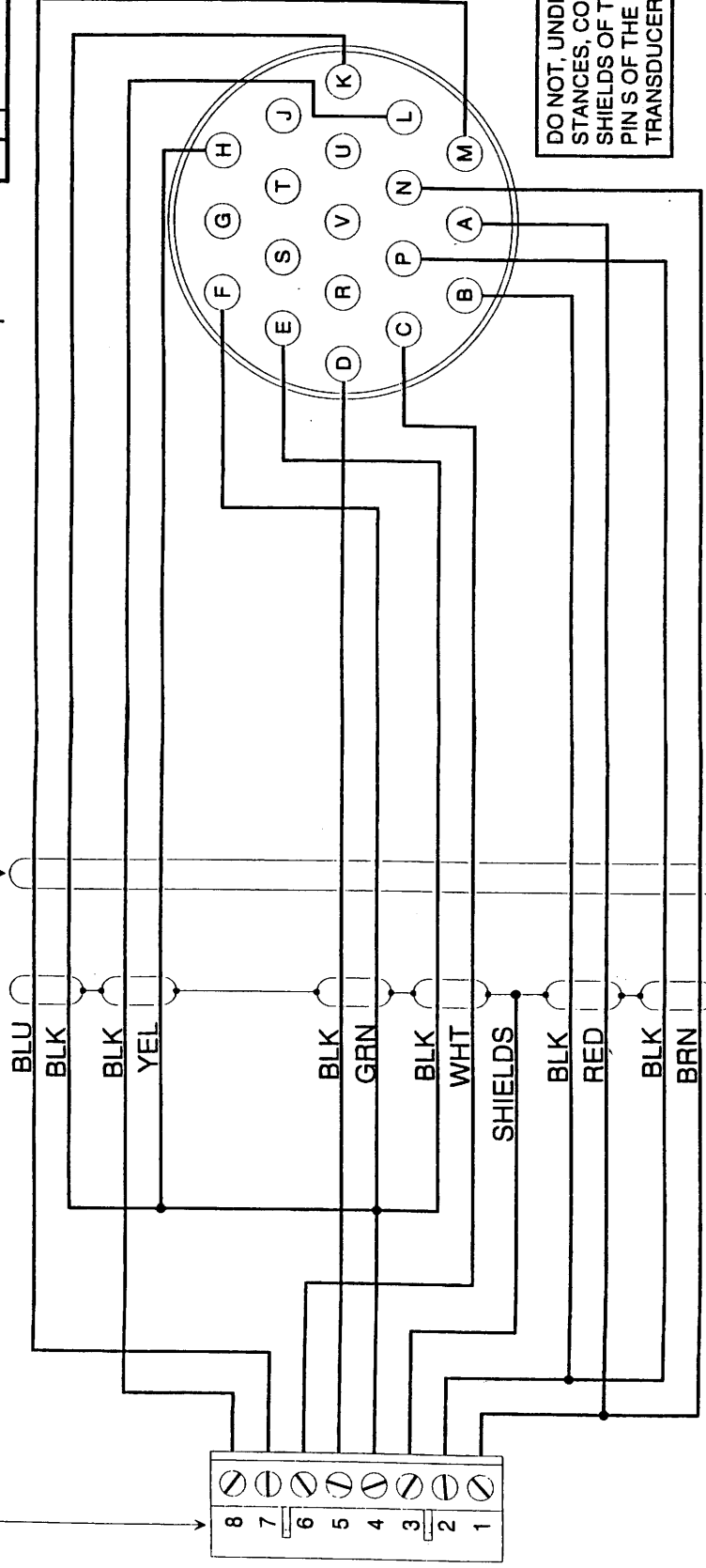

Transducer Connector
 Mates with Autotech SAC-RL210-G128M Transducer.

DO NOT, UNDER ANY CIRCUMSTANCES, CONNECT THE SHIELDS OF THE CABLE TO PINS OF THE AUTOTECH TRANSDUCER CONNECTOR.

Connections are for CW increasing readings
 For CCW increasing readings, reverse WHT/BLK Pair (Pins C&E), and YEL/BLK Pair (Pins H&L).

NOTE: This print is for use with AMCI Modules specifically designed to use the Autotech SAC-RL210-G128M Transducer. This Autotech transducer does not interface with AMCI standard product.

1460/1960 Users:
 Pin 1 of the Transducer Input Connector is located towards the top of the module, NOT the bottom as this drawing may imply. Reversing the wires on the Module Connector will not harm the module or the transducer, but the transducer will not operate. **IF YOUR MODULE HAS A REMOTE DISPLAY OPTION**, the Module Connector must be a MS-8W. Refer to Print B1191.

TOLERANCES (EXCEPT AS NOTED)	AMCI ADVANCED MICRO CONTROLS, INC.
DECIMAL	AUTOTECH
FRACTIONAL	SAC-RL210-G128M
ANGULAR	None
SCALE	DRAWN BY D/W/N
TITLE	APPROVED BY JRS
Transducer Cable Drawing	
DATE	DRAWING NUMBER
7/12/91	B1160 REV. B

DATE	SYM	REVISION RECORD	AUTH	DR	CHK

Module Connector
 Mates with all AMCI Single Channel Multi-turn Absolute Resolver Products
 AMCI Part #: MS-8W
 Phoenix #: MVSTBW 2.5/8-ST-5.08

BELDEN 9731 Cable or exact equ..

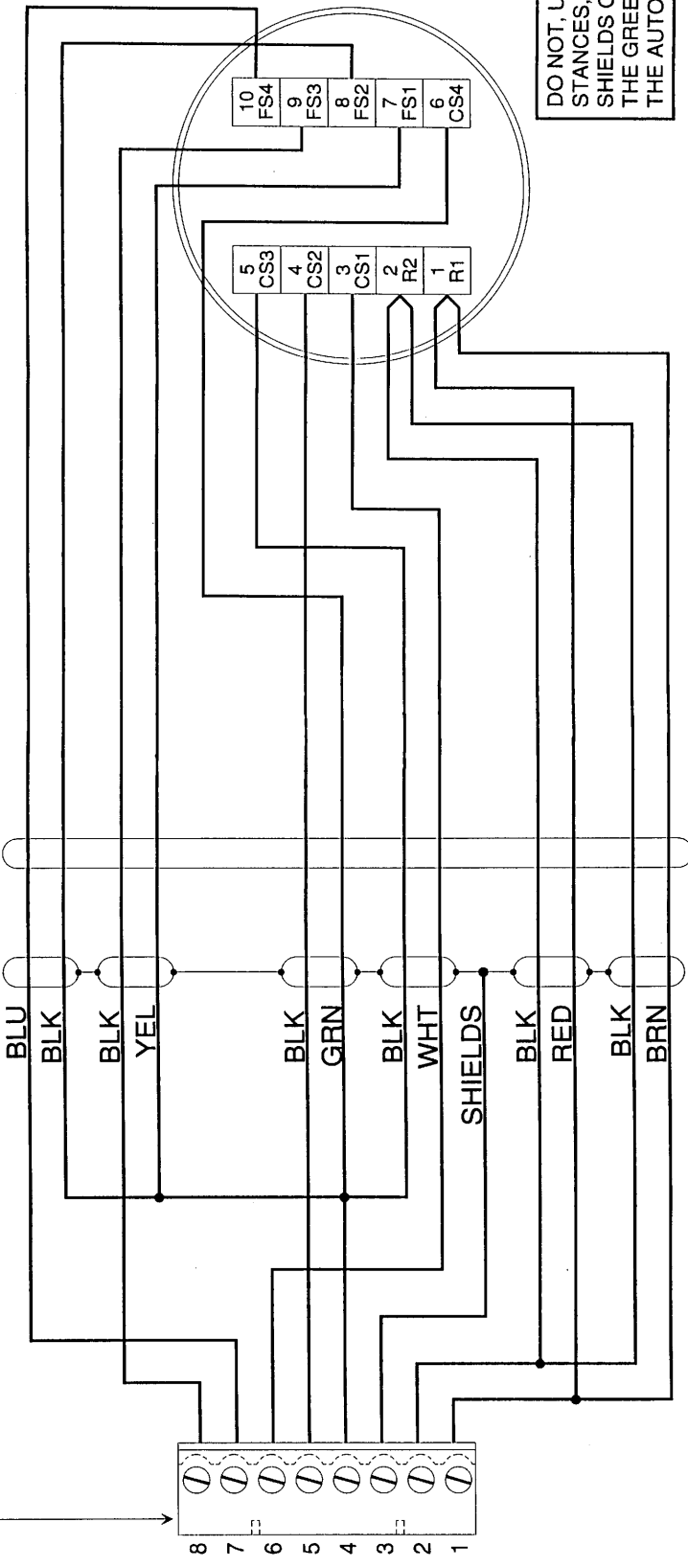

Transducer Connector
 Autotech
 SAC-RL210-G128
 Transducer.

DO NOT, UNDER ANY CIRCUMSTANCES, CONNECT THE SHIELDS OF THE CABLE TO THE GREEN GND SCREW OF THE AUTOTECH TRANSDUCEUR.

Connections are for CW increasing readings
 For CCW increasing readings, reverse WHT/BLK Pair (Pins 3&5), and YEL/BLK Pair (Pins 7&9).

NOTE: This print is for use with AMCI Modules specifically designed to use the Autotech SAC-RL210-G128 Transducer. This Autotech transducer does not interface with AMCI standard product.

1460/1960 Users:
 Pin 1 of the Transducer Input Connector is located towards the top of the module, NOT the bottom as this drawing may imply. Reversing the wires on the Module Connector will not harm the module or the transducer, but the transducer will not operate.

TOLERANCES (EXCEPT AS NOTED)	AMCI ADVANCED MICRO CONTROLS INC.		
DECIMAL	AUTOTECH	SCALE	DRAWN BY DWN
FRACTIONAL	SAC-RL210-G128	None	APPROVED BY LR
ANGULAR	TITLE Transducer Cable Drawing w/ MS-8W		
DATE	3/9/93	DRAWING NUMBER	B1192

Module Connector

Mates with all AMCI Single Channel Multi-turn Absolute Resolver Products
 AMCI Part #: MS-8
 Phoenix #: MSTB 1.5/8-ST-5.08

BELDEN 9731 Cable or exact equ..

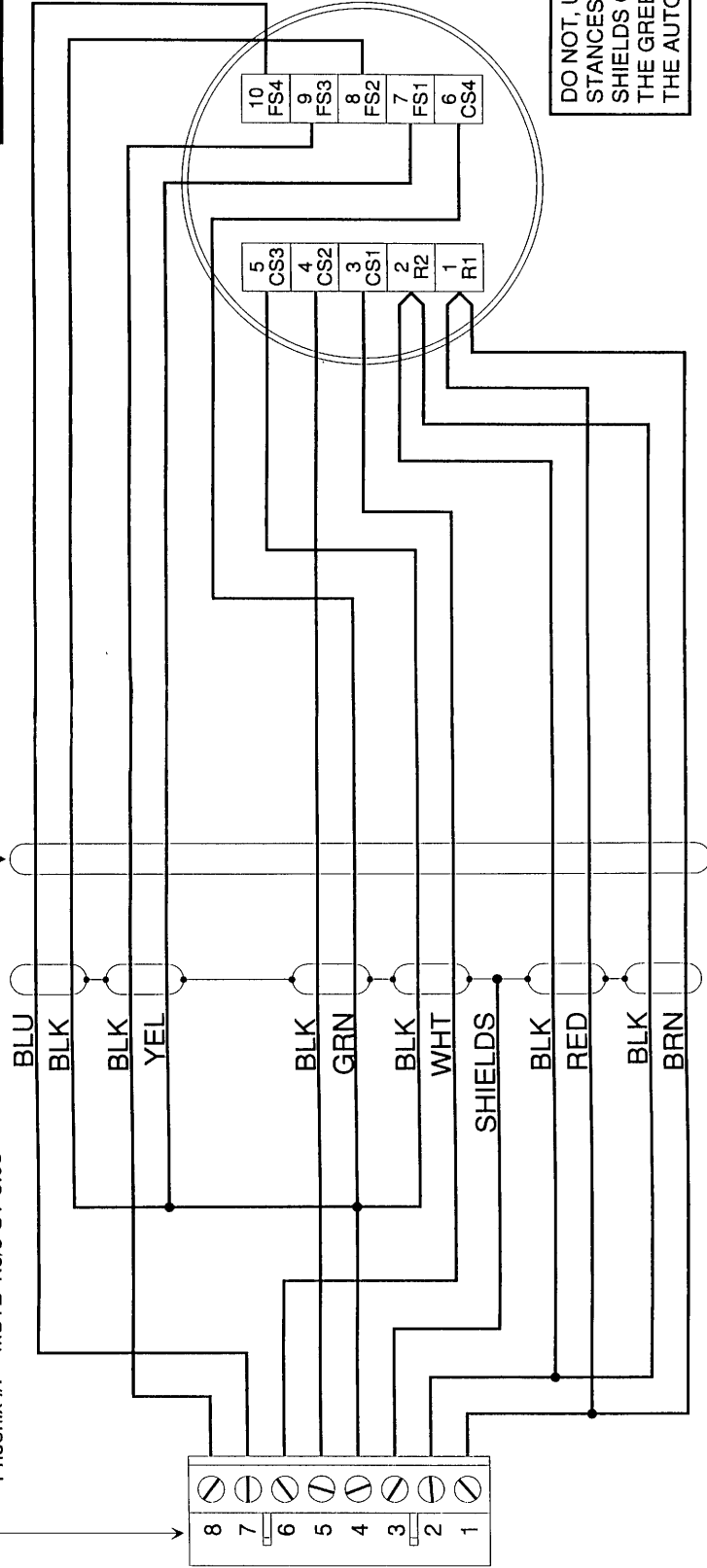

Transducer Connector
 Autotech
 SAC-RL210-G128 Transducer.

DO NOT, UNDER ANY CIRCUMSTANCES, CONNECT THE SHIELDS OF THE CABLE TO THE GREEN GND SCREW OF THE AUTOTECH TRANSDUCER.

Connections are for CW increasing readings
 For CCW increasing readings, reverse WHT/BLK Pair (Pins 3&5), and YEL/BLK Pair (Pins 7&9).

NOTE: This print is for use with AMCI Modules specifically designed to use the Autotech SAC-RL210-G128 Transducer. This Autotech transducer does not interface with AMCI standard product.

1460/1960 Users:

Pin 1 of the Transducer Input Connector is located towards the top of the module, NOT the bottom as this drawing may imply. Reversing the wires on the Module Connector will not harm the module or the transducer, but the transducer will not operate. **IF YOUR MODULE HAS A REMOTE DISPLAY OPTION**, the Module Connector must be a MS-8W. Refer to Print B1192.

DATE	SYM	REVISION RECORD	AUTH	DR	CK
1/93	A	Added CW/CCW Note	D/W/N		
3/93	B	Added Compatibility and 1460/1960 Note	D/W/N		

TOLERANCES (EXCEPT AS NOTED)	ADVANCED MICRO CONTROLS, INC.		
DECIMAL	AUTOTECH	SCALE	DRAWN BY D/W/N
FRACTIONAL	SAC-RL210-G128	None	APPROVED BY JRS
ANGULAR	TITLE Transducer Cable Drawing		
#	DATE 7/12/91	DRAWING NUMBER	B1161 REV. B

AMCI

ADVANCED MICRO CONTROLS INC.

PLYMOUTH INDUSTRIAL PARK., TERRYVILLE, CT 06786 T: (203) 585-1254 F: (203) 584-1973

LEADERS IN ADVANCED CONTROL PRODUCTS