

NEXUS

Resolver Interface Unit

NX2A4C

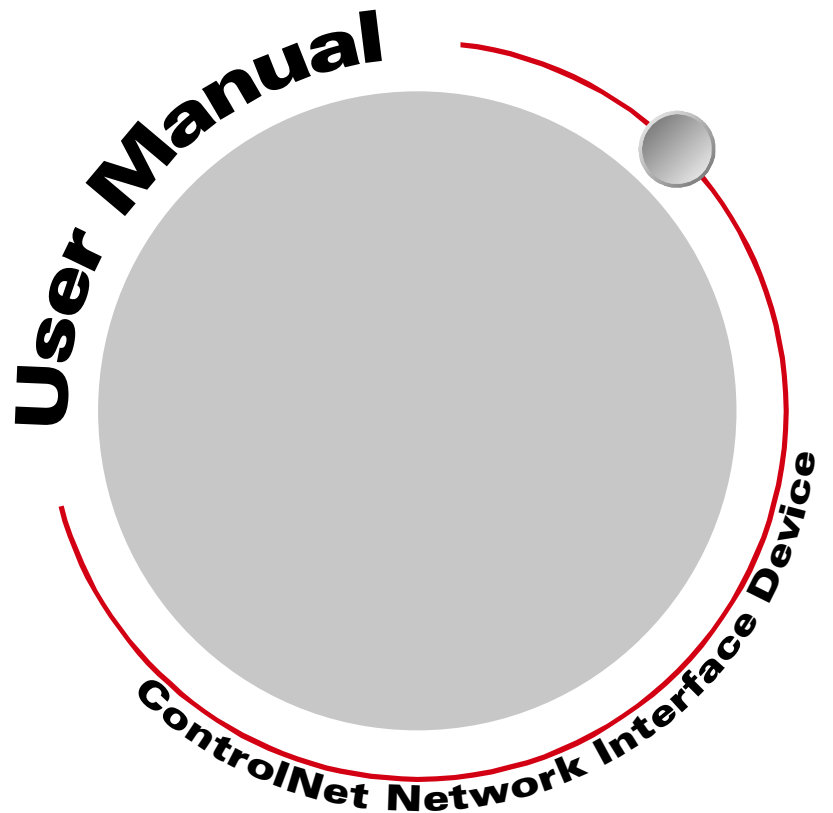

GENERAL INFORMATION

Important User Information

The products and application data described in this manual are useful in a wide variety of different applications. Therefore, the user and others responsible for applying these products described herein are responsible for determining the acceptability for each application. While efforts have been made to provide accurate information within this manual, AMCI assumes no responsibility for the application or the completeness of the information contained herein.

UNDER NO CIRCUMSTANCES WILL ADVANCED MICRO CONTROLS, INC. BE RESPONSIBLE OR LIABLE FOR ANY DAMAGES OR LOSSES, INCLUDING INDIRECT OR CONSEQUENTIAL DAMAGES OR LOSSES, ARISING FROM THE USE OF ANY INFORMATION CONTAINED WITHIN THIS MANUAL, OR THE USE OF ANY PRODUCTS OR SERVICES REFERENCED HEREIN.

Throughout this manual the following two notices are used to highlight important points.



WARNINGS tell you when people may be hurt or equipment may be damaged if the procedure is not followed properly.



CAUTIONS tell you when equipment may be damaged if the procedure is not followed properly.

No patent liability is assumed by AMCI, with respect to use of information, circuits, equipment, or software described in this manual.

The information contained within this manual is subject to change without notice.

Standard Warranty

ADVANCED MICRO CONTROLS, INC. warrants that all equipment manufactured by it will be free from defects, under normal use, in materials and workmanship for a period of [1] year. Within this warranty period, AMCI shall, at its option, repair or replace, free of charge, any equipment covered by this warranty which is returned, shipping charges prepaid, within one year from date of invoice, and which upon examination proves to be defective in material or workmanship and not caused by accident, misuse, neglect, alteration, improper installation or improper testing.

The provisions of the "STANDARD WARRANTY" are the sole obligations of AMCI and excludes all other warranties expressed or implied. In no event shall AMCI be liable for incidental or consequential damages or for delay in performance of this warranty.

Returns Policy

All equipment being returned to AMCI for repair or replacement, regardless of warranty status, must have a Return Merchandise Authorization number issued by AMCI. Call (860) 585-1254 with the model number and serial number (if applicable) along with a description of the problem. A "RMA" number will be issued. Equipment must be shipped to AMCI with transportation charges prepaid. Title and risk of loss or damage remains with the customer until shipment is received by AMCI.

24 Hour Technical Support

24 Hour technical support is available on this product. If you have internet access, start at our website, www.amci.com. Product documentation and FAQ's are available on the site that answer most common questions.

If you require additional technical support, call (860) 583-7271. Your call will be answered by the factory during regular business hours, Monday through Friday, 8AM - 5PM EST. During non-business hours an automated system will ask you to enter the telephone number you can be reached at. Please remember to include your area code. The system will page an engineer on call. Please have your product model number and a description of the problem ready before you call.

TABLE OF CONTENTS

General Information

Important User Information	IFC
Standard Warranty	IFC
Returns Policy	IFC
24 Hour Technical Support	IFC

About This Manual

Audience	3
Navigating this Manual	3
Revision Record	3
Revision History	3

Specifications

Specifications	4
----------------------	---

Chapter 1: Introduction

Overview	5
Advantages	5
Front Panel Description	6
Status LED's	6
Stop Time Monitoring	8
AMCI Compatible Transducers	9
Single Turn Transducers	9
Multi-Turn Transducers	10
Transducer Specifications	11
Single-Turn Transducers	11
Multi-Turn Transducers	11
Other Compatible Transducers	12
Supported Single-Turns	12
Supported Multi-Turns	13
Programmable Parameters	13
Resolver Type	13
Transducer Fault Latch	14
Count Direction	14
Tachometer Response	14
Transducer Type	14
Number of Turns	15
Full Scale Count	15
Linear Offset	16
Preset Value	16
Backplane Programming	16
Programming Cycle	16

Chapter 2: Installation

General Guidelines	17
Wiring	17
Grounding	17
Surge Suppression	17
Mounting	17
Required Power Supply	17
Mounting the NX2A4C	18
DIN Rail Mounting	18
Panel Mounting	19
Attaching the DIN Brackets	20
Attaching the Panel Brackets	20
Transducer Input Connectors	20
Transducer Connector Pin Outs	21
Transducer Cable Installation	21
C1T-(x) Wiring Diagram	21
C2T-(x) Wiring Diagram	22
CTT-(x) Wiring Diagram	22
AMCI Transducer Mounting	23
AMCI Transducer Outline Drawings	23
Autotech Transducer Installation	23
Brake Input Wiring	23
Input Connector	23
Connector Wiring	24
Connecting to the ControlNet Network ...	24
Setting the Node Address	24
Physically Attaching to the Network	24
Connecting Power	25

Chapter 3: Controlnet Configuration

Getting the EDS and Icon Files	27
Before You Begin	27
Adding a NX2A4C to a SLC 500 System	27
Adding a NX2A4C to a ControlLogix System	27
RSLogix 5000 Setup	27
RSNetWorx Setup	28
Adding a NX2A4C to a PLC-5 System ...	29
RSNetworx Setup	29

Chapter 4: Data Format & Programming

Output Data Words	31
Multi-Word Format	31
Control Word Format	31
Configuration Word Format	33
Single-Turn Parameter Ranges and Factory Defaults	33
Multi-Turn Parameter Ranges and Factory Defaults	34
ControlLogix Input Data Format	35
Data Blocks	35
Multi-Word Format	35
PLC-5 Input Data Format	36
Data Blocks	36
Multi-Word Format	36
Status Word Format	37
Programming Error Bits	37
Transducer & Unit Status Bits	38

Chapter 5: Sample Program

Ladder Logic Format	39
PLC-5 Data Format	39
ControlLogix Data Format	39
Data Values	40
Ladder Logic	41

Appendix A: Shut Height Setup Example

Background	43
Definitions	43
Example Assumptions	43
Calculating the Full Scale Count Parameter	44
Calculating the Linear Offset Parameter	44
Determining the Preset Value	44
Programming the NX2A4C	44
Verifying the Setup	45

ABOUT THIS MANUAL

Audience

This manual explains the operation, installation, and programming of the AMCI Nexus Resolver Interface for ControlNet networks. The module number of this product is NX2A4C. This unit accepts up to four resolvers and supplies position, tachometer, and status information to the network on every update. It can be configured to accept four single-turn resolver transducers, two multi-turn resolver transducers, or two single-turn and one multi-turn resolver transducers. The Nexus Resolver Interface can be programmed to use AMCI or Autotech transducers.

Written for the engineer responsible for incorporating the Nexus Resolver Interface into a design as well as the engineer or technician responsible for its actual installation, this manual contains information on hardware and software configuration as well as data on compatible transducers and proper installation techniques.

Manuals at AMCI are constantly evolving entities. Your questions and comments on this manual and the information it contains are both welcomed and necessary if this manual is to be improved. Please direct all comments to: Technical Documentation, AMCI, 20 Gear Drive, Terryville CT 06786, or fax us at (860) 584-1973. You can also e-mail your questions and comments to techsupport@amci.com

“Nexus”, and the AMCI logo are trademarks, and “AMCI” is a registered trademark of Advanced Micro Controls Inc. Allen-Bradley, ControlLogix, RSLogix 5000, PLC-5, Rockwell Software, RSLinx, RSNetWorx, and SLC are trademarks of Rockwell Automation. ControlNet is a trademark of ControlNet International, Ltd. “Adobe” and Acrobat are registered trademarks of Adobe Systems Incorporated.

All other trademarks contained herein are the property of their respective holders.

Navigating this Manual

The layout of this manual allows it to be used in both printed and on-line formats. Its on-line form is a PDF document, which requires Adobe Acrobat Reader version 4.0 or a similar reader before you can access it.

Bookmarks of all the chapter names, section headings, and sub-headings were created in the PDF file so that you can easily find what you are looking for. The bookmarks should appear when you open the file. If they don't, press the F5 key on Windows platforms to bring them up.

Throughout this manual you will also find *green text that functions as a hyperlink* in HTML documents. Clicking on the text will immediately jump you to the referenced section of the manual. If you are reading a printed manual, most links have the page numbers included.

The PDF file is password protected to prevent changes to the document. You are allowed to select and copy sections for use in other documents and, if you own Adobe Acrobat version 4.05 or later, you are allowed to add notes and annotations.

Revision Record

This manual, 940-0N011, is the second release of the manual. It give information on downloading the EDS and icon files from the amci.com site. It was first released 4/9/2001.

Revision History

- 940-0N011: 04/09/2001. Added EDS on website information.
- 940-0N010: 01/31/2001. Initial Release.

SPECIFICATIONS

ControlNet Interface

Supports single and redundant media. Software configuration through EDS file. Tested with A-B PLC-5 and ControlLogix platforms.

Minimum Network Update Time

5 milliseconds. The network update time can be programmed to greater values.

Data I/O Words

Requires a maximum of 23 input and 10 output words.

Compatible Transducers

Any AMCI single or multi-turn, resolver based transducer. Can be programmed to use Autotech single-turn and 128-turn transducers. Supports other transducers through the use of AMCI RM reference modules.

Number of Transducer Inputs

Four single-turn inputs. Two single turn inputs can be configured as one multi-turn input.

Available configurations are:

Four single-turn inputs

Two single-turn and one multi-turn inputs

Two multi-turn inputs

Transducer Input Isolation

Transformer Isolated.

Transducer Position Resolution

All single-turns[†]: 1 part in 8,192

AMCI 100, 180 turn: 1 part in 4,096 per turn

AMCI 1000, 1800 turn: 1 part in 409.6 per turn

Autotech multi-turn: 1 part in 1,024 per turn

New Position Update Time

200 microseconds.

Tachometer Resolution

1 RPM

Tachometer Range

Theoretical: 1 to 65,536 RPM

AMCI Transducer Limit: 1 to 5,000 RPM

[†] Includes all geared, single resolver transducers

Stop Time Monitor

On board timer measures the time between the on to off transition of a digital input and the cessation of movement on transducer channel one. Channel one must be configured for a single-turn transducer.

Most commonly used in press applications to monitor brake functionality.

Programmable Parameters

Resolver Type

Transducer Fault Latch

Count Direction

Tachometer Response

Transducer Type (multi-turn only)

Number of Turns (multi-turn only)

Full Scale Count

Linear Offset

Preset Value

Stop Time Digital Input

10 to 30 Vdc isolated input. Requires 10 mA minimum to operate

NX2A4C Power Requirements

18 to 30 Vdc external power, 24 Vdc recommended.

Requires 12 watts of power. (0.5A@24 Vdc)

NX2A4C Mounting

DIN rail or panel mount. Kit included with unit that allows customer to change mounting styles. DIN channel can be EN 50 002 or EN 50 035.

Environmental Conditions

Operating Temperature: 0 to 60°C

Relative Humidity 5 to 95%
(without condensation)

Storage Temperature: -40 to 85°C

NEMA Rating

NEMA 1. Must be mounted in a suitable enclosure to protect it from airborne and liquid contaminants.

CHAPTER 1

INTRODUCTION

Overview

As industrial control technology evolves, the way control systems are designed evolves as well. Presently, many markets are using a *distributed I/O structure*, where sensors and controls are placed throughout the machine and tied together over a common network instead of running wire for each sensor and control back to a centralized location. This type of structure can greatly reduce wiring costs and increase overall system reliability. The *NEXUS* line of products from AMCI is another of our responses to this market trend.

Figure 1.1 is a picture of the NX2A4C, one of five products that presently exist in the Nexus product line. All of the products use ControlNet as their network interface for communication with A-B PLC's. The other four products in the Nexus family are:



Figure 1.1 Nexus Resolver Interface (NX2A4C)

- ▶ **NX2C4C:** Four channel LDT interface. Accepts AMCI, Balluff, and Temposonic transducers. Reports position, velocity, and fault diagnostic information.
- ▶ **NX2C4C-08:** Four channel multiple magnet LDT interface. Accepts AMCI, Balluff, and Temposonic transducers. Allows up to sixteen magnets per transducer. Reports position, velocity, and fault diagnostic information.
- ▶ **NX2E4C:** Four channel SSI interface. Accepts any transducer that outputs SSI data. Supports 1 to 32 bit transfers with a data value programmable from 1 to 28 bits. Reports Data Value, Rate of Change, fault diagnostics, and raw SSI data.
- ▶ **NX3B1C:** One resolver input, programmable limit switch. Sixteen digital inputs and sixteen solid state relay outputs. Eight outputs available on-board, additional eight output available from an external relay board.

Additional information on these products is available on our website, www.amci.com.

Advantages

Using the Nexus Resolver Interface gives you several advantages over traditional “black boxes” or PLC plug-in cards.

- ▶ The NX2A4C can be placed closer to the transducers, thereby reducing the wiring needed to bring the resolvers into the PLC from multiple transducer cables down to a single coaxial cable.
- ▶ Using the NX2A4C future-proofs your resolver feedback design. If you later decide upgrade your system from a SLC or PLC-5 to a ControlLogix and you used a traditional module, you would need to invest in a new module for the ControlLogix platform. By using the NX2A4C, you unplug the ControlNet cable from the old system and plug it into the new one. After configuring the new system, the resolver interface will work exactly as it did before.
- ▶ The NX2A4C gives OEM's the advantage of design re-usability. Instead of designing a resolver interface for every PLC that customers require, using the NX2A4C allows OEM's to design a machine's resolver interface once, and reuse the design regardless of the PLC platform the customer decides upon.
- ▶ The ability to configure the NX2A4C to accept two single-turn and one multi-turn transducer is advantageous in several industries, such as press automation. This unit gives press builders crankshaft angle indication on a single-turn channel and shut height indication on the multi-turn channel, combining the functions of two separate boxes or modules into one. To further aid press integrators, the NX2A4C also includes a brake input that can be used to measure crankshaft stopping time.

Front Panel Description

Figure 1.2 shows the front panel layout of the NX2A4C Resolver Interface. Note that the unit ships with four Phoenix Contact connectors that are not shown for clarity. The RS485 channel, which is not implemented at this time, does not ship with a connector.

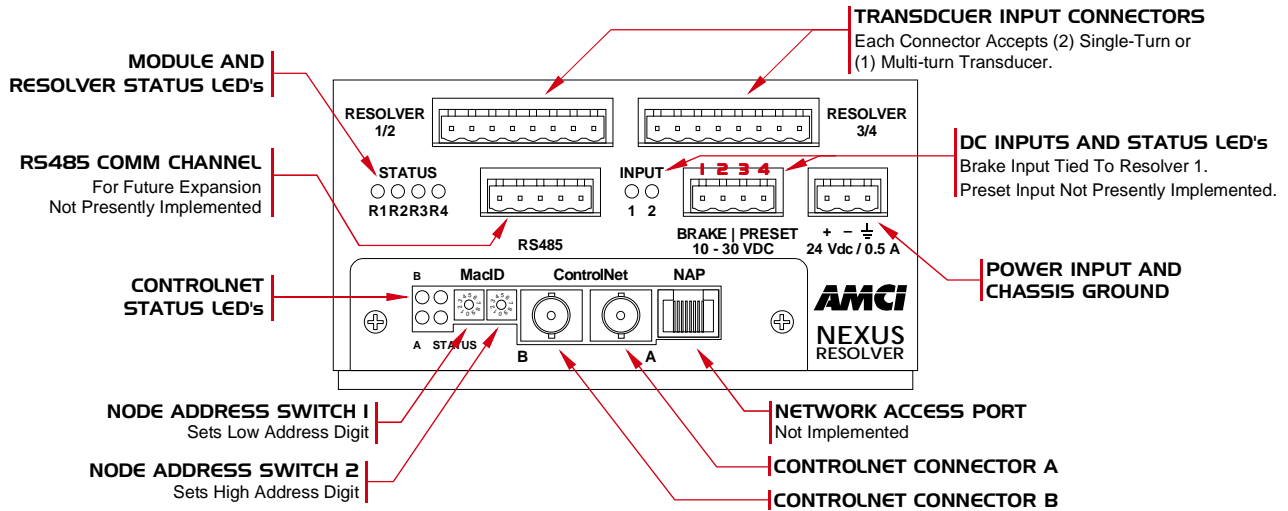

Figure 1.2 Front Panel Layout

Status LED's

There are three sets of status LED's on the NX2A4C, Unit and Resolver Status, Input Status, and ControlNet Status.

Unit and Resolver Status

These four red/green bi-color LED's are used to indicate a problem with the NX2A4C or the transducer connections. Figure 1.3 shows the available flashing patterns and their meaning.

- A Unit Fault is indicated by turning on all of the LED's red. This fault display takes precedence over the transducer fault displays.
- When indicating transducer status, each LED corresponds to a resolver. Multi-turn transducers have two resolvers in them. See [Multi-Turn Transducers](#) on page 10 for a full description of how AMCI multi-turn transducers work. When using a multi-turn resolver, the odd numbered LED corresponds to the coarse resolver while the even numbered LED corresponds to the fine resolver.
- You have the option of disabling the LED if you are not using the channel. The channel will still function normally, but the unit will not give any indication of the channels status.

STATUS
○○○○
R1R2R3R4

- UNIT AND RESOLVER STATUS LED's**
- ALL ON RED: Unit Fault
 - FLASHING RED: Non-Clearable Transducer Fault
 - FLASHING GREEN: Clearable Transducer Fault
 - ON GREEN: Transducer OK.
 - OFF: LED Disabled

Figure 1.3 Unit Status LED's

Front Panel Description (continued)

Status LED's (continued)

ControlNet Status

The four red/green bi-color LED's on the ControlNet adapter show the status of the network channels and status of the internal communications between the adapter and the rest of the unit. Table 1.1 below gives the various indications and their meaning.

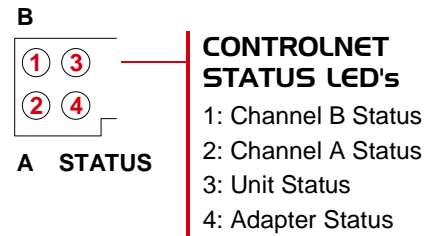

Figure 1.4 ControlNet Status LED's

LED State	LED 1 Ch B Status	LED 2 Ch A Status	LED 3 Unit Status	LED 4 Adapter Status
OFF	Channel Disabled	Channel Disabled	The NX2A4C is not communicating with the ControlLogix master.	No power to the ControlNet Adapter
ON Green	Channel OK	Channel OK	The NX2A4C is communicating with the ControlLogix master.	ControlNet Adapter is initialized and operating correctly
ON Red				Major ControlNet Adapter fault. Cycle power to the NX2A4C.
Blinking Green				ControlNet Adapter is waiting to be initialized
Blinking Red	Channel Disconnected	Channel Disconnected		Minor ControlNet Adapter fault. Cycle power to the NX2A4C.

Table 1.1 ControlNet Status LED's

Input Status

These two red/green bi-color LED's are used to indicate the on/off status of the BRAKE and PRESET inputs. Note that the PRESET function is not presently implemented. LED 2 will come on when power is applied to the PRESET input, but the NX2A4C will not change any position values. The BRAKE input is tied to channel 1. When this input transitions from on to off, the unit starts a timer and stops the timer when it does not detect a change in position on channel 1 for 125 milliseconds. It then reports this time over the network along with the channel 1 position when the input transitioned. See the next section, *Stop Time Monitoring*, for a complete description of how the brake input is used.

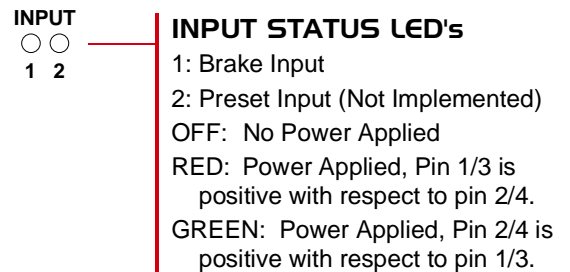

Figure 1.5 Input Status LED's

Stop Time Monitoring

If you are using the NX2A4C in a press control application, you can use the stop time monitoring feature to measure the stopping time of the crankshaft. The stop time monitor on the unit measures the time between the on-to-off transition of the Brake Input and the stopping of the transducer attached to channel one. Note that channel one must be configured as a single-turn channel to use the stop time monitor. The Stop Time Timer measures a stopping time of 34 milliseconds to 9.999 seconds with a resolution of 1 millisecond.

The NX2A4C also captures the position at which the brake is applied and reports this information, along with the stopping time, when a brake cycle is completed. This information is reported over the network until the next brake cycle finishes.

If you are not using the unit in a press control application, you can leave the Brake Input un-wired and the Stop Time monitor will never be triggered.

The stop time monitor is a monitoring feature only. Any determination of the correct operation of the press brake must be made by the system PLC through a user developed ladder logic program.

Figure 1.6 shows how the stop time is measured.

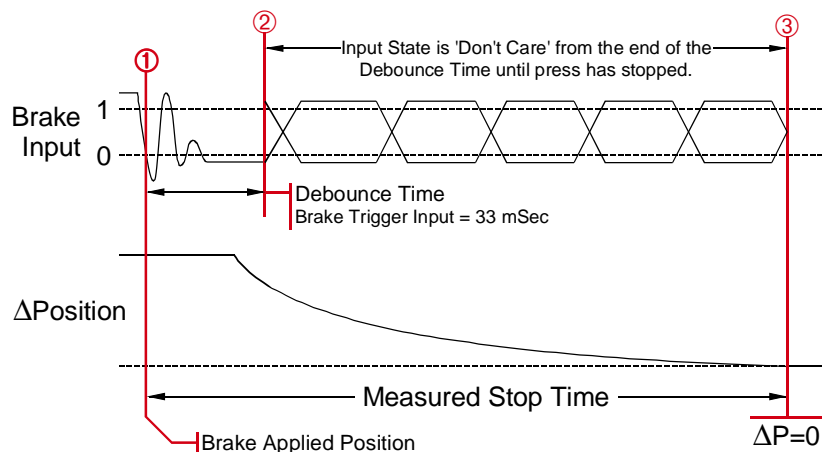

Figure 1.6 Stop Time Measurement

- 1) The NX2A4C captures the Brake Applied Position and starts the Stop Time Timer when the Brake Input makes a 1→0 (on→off) transition. The Brake Applied Position is not immediately placed in the input data. It is updated, along with the Stop Time, when the brake cycle completes.
 - a) If the Brake Input returns to its normal state for sixteen milliseconds in the next thirty-four, the input transition is considered noise and the brake cycle is aborted. The next transition on the Brake Input starts another brake cycle.
 - b) If the Brake Trigger Input is not in its active state for twelve of the last sixteen milliseconds of the thirty-four millisecond debounce time, the input transition is considered noise and the brake cycle is aborted. If the input is in its active state at the end of the thirty-four milliseconds, the brake cycle will begin again immediately. If the input is in its normal state, the brake cycle will start on the next transition.
- 2) Once the debounce time is exceeded, the state of the brake trigger is ignored until the brake cycle is complete. From this point on, the Stop Time timer runs until the transducer position stops changing. The 'ΔPosition' section of the diagram shows the press coming to a stop.
- 3) The Stop Time timer stops when the change in position value equals zero. The transducer is considered stopped when there is less than 1/2,048th of a rotation made in 125 milliseconds. This translates into less than one turn every 4.2 minutes. Obviously, it takes 125 milliseconds to determine that the position has not changed for that amount of time. Therefore, the Stop Time timer runs until the transducer does not move for 125 milliseconds, and it then subtracts 125 milliseconds from the Stop Time value.

AMCI Compatible Transducers

Single Turn Transducers

Table 1.2 lists the AMCI single-turn transducers that are compatible with the Nexus Resolver Interface.

Model	Shaft	Mount	Turns	Comments
R11X-J10/7	0.120"	Servo	1	NEMA 1, size 11 resolver. Leads only, no connector.
R11X-J12/7	0.188"	Servo	1	NEMA 1, size 11 resolver. Leads only, no connector.
HT-6	0.188"	Front/Side	1	NEMA 13 R11X-J12/7 transducer
HT-20	0.625"	Front/Side	1	NEMA 4 heavy duty transducer
HT-20S	0.625"	Front/Side	1	HT-20 with side connector
HT-20C	0.625"	Front/Side	1	NEMA 4X stainless steel HT-20 w/ Viton® shaft seal, and 0.5" NPT thread for conduit connection. Internal terminal plug for resolver connections.
HT-20K	0.625"	Front/Side	1	NEMA 4X hard coat anodized HT-20, stainless steel shaft w/ Viton shaft seal.
HT-20KS	0.625"	Front/Side	1	HT-20K with side connector.
HT-20L	0.625"	Front/Side	1	NEMA 4X hard coat anodized HT-20, stainless steel shaft w/ Nitrile shaft seal.
HT-20LS	0.625"	Front/Side	1	HT-20L with side connector.
H25-FE	0.375"	Flange	1	NEMA 4, size 25, end connector
H25-F1E	0.375"	Flange	1	NEMA 4, size 25, end connector. Bolt-in replacement for Namco/C&A HT-11B transducers.
H25-FS	0.375"	Flange	1	NEMA 4, size 25, side connector
H25-FL	0.375"	Flange	1	NEMA 4, size 25, integral 15 foot (3 meter) cable
H25-SE	0.375"	Servo/Front	1	NEMA 4, size 25, end connector
H25-SS	0.375"	Servo/Front	1	NEMA 4, size 25, side connector
H25-SL	0.375"	Servo/Front	1	NEMA 4, size 25, integral 15 foot (3 meter) cable
HT-400	0.625"	Front	1	NEMA 4, Bolt-in replacement for Autotech RL100 transducers. Also has HT-20 bolt pattern. 1" NPT thread for conduit connection. Internal terminal strip for resolver connections.
HT-400-1E	0.625"	Front	1	Same as HT-400 with an AMCI MS connector instead of a conduit connection.
HT-20-(x)	0.625"	Front	(x)†	HT-20 with internal (x):1 gear ratio
HTT-20-1	0.625"	Front	1‡	Redundant single turn resolvers, single MS connector
HTT-400-1	0.625"	Front	1‡	Redundant single turn resolvers. Bolt-in replacement for Autotech RL220 transducers. Dual AMCI MS connectors.

† Available gear ratios are: 2:1, 2.5:1, 2.77:1, 3:1, 4:1, 4.8:1, 5:1, 6:1, 7:1, 8:1, 9:1, 10:1, 12:1, 13:1, 15:1, 16:1, 18:1, 20:1, 24:1, 36:1, 40:1, 50:1, 60:1, 64:1, 100:1, 105:1, 150:1, 180:1, 250:1 and 256:1. Additional gear ratios may be available. Check our website, www.amci.com, for an up-to-date listing.

‡ This package contain two resolvers geared 1:1 with the input shaft. Most commonly used in systems that mandate redundant sensors, AMCI can install two different size 11 resolvers in the package per customer requirements. Contact AMCI for more information.

Table 1.2 Compatible AMCI Transducers

AMCI Compatible Transducers (continued)
Multi-Turn Transducers

Table 1.3 lists the AMCI multi-turn transducers that are compatible with the NX2A4C.

Model	Shaft	Mount	Turns	Comments
HTT-20-100	0.625"	Front	100	NEMA 4 heavy duty transducer
HTT-20-180	0.625"	Front	180	NEMA 4 heavy duty transducer
HTT-20-1000	0.625"	Front	1,000	HTT-20-100 w/ additional 10:1 gearing on input shaft.
HTT-20-1800	0.625"	Front	1,800	HTT-20-180 w/ additional 10:1 gearing on input shaft.
HTT425-Ann-100†	0.250"	Motor	100	A-B Series 1326 motor mount transducer. "nn" in part number defines connector style.
HTT425-Mnn-100†	10 mm	Motor	100	Universal motor mount w/ required adapter plate. "nn" in part number defines connector style.
HTT425-Fnn-100†	0.625"	Front	100	NEMA 4X, HTT-20-100 w/ Viton shaft seal. "nn" in part number defines connector style.
HTT425-Tnn-100†	0.625"	Foot	100	NEMA 4X, HTT-20-100 w/ Viton shaft seal. "nn" in part number defines connector style.
HTT-400-180	0.625"	Front	180	NEMA 4, HTT-20-180. Bolt-in replacement for Autotech RL210 transducers. Also has HTT bolt pattern. 1" NPT thread for conduit connection. Internal terminal strip for resolver connections.
HTT-400-180E	0.625"	Front	180	Same as HTT-400-180 with MS connector instead of a conduit connection.

† A 1,000 turn version is also available. Refer to www.amci.com for more information on available connector styles.

Table 1.3 Compatible AMCI Transducers

Each multi-turn transducer contains two resolvers. The first resolver, called the fine resolver, is attached directly to the input shaft through a coupler. The second resolver, called the coarse resolver, is geared to the fine. This gear ratio, either 99:100 or 179:180, determines the number of turns the transducer can encode.

At the mechanical zero of the transducer, the electrical zeros of the two resolvers are aligned. See Figure 1.7A. After one complete rotation, the zero of the coarse resolver lags behind the zero of the fine by one tooth, either 1/100 or 1/180 of a turn. After two rotations the lag is 2/100 or 2/180. See Figures 1.7B and 1.7C. After 100 or 180 turns, the resolvers' electrical zeros are realigned and the cycle begins again.

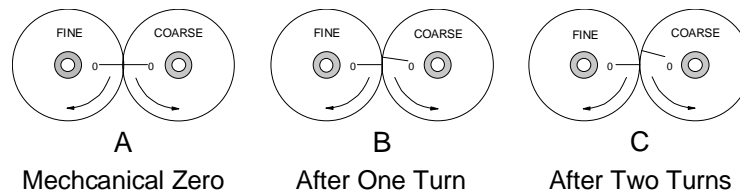

Figure 1.7 Resolver Alignment in Multi-turn Transducers

The fine resolver yields the absolute position within the turn directly. Using a proprietary algorithm, the module determines the number of turns completed by the difference in positions of the two resolvers. The absolute multi-turn position is then calculated as ((number of turns completed * counts per turn) + fine resolver position).

The 1,000 and 1,800 turn transducers have a 10:1 gear ratio between the input shaft and the resolvers. Therefore they can encode ten times the number of turns but at a tenth of the resolution.

Transducer Specifications

Single-Turn Transducers

The following table contains the mechanical and environmental specifications for all AMCI single-turn transducers that are compatible with the NX2A4C.

Specification	All HT-20's	All HT-20-(x), HT-400, HTT-20-1, & HTT-400-1	All H25's	HT-6	All R11's
Shaft Diameter	0.625"	0.625"	0.375"	0.188"	0.120" or 0.188"
Radial Shaft Loading	400 lbs. max.	400 lbs. max.	40 lbs. max.	8 lbs. max.	2 lbs. max.
Axial Shaft Loading	200 lbs. max.	200 lbs. max.	20 lbs. max.	4 lbs. max.	1 lb. max.
Starting Torque	8 oz-in @ 25°C	8 oz-in @ 25°C	1.5 oz-in @ 25°C	0.5 oz-in @ 25°C	0.1 oz-in @ 25°C
Moment of Inertia (oz-in-sec ²)	6.25 X 10 ⁻⁴	8.75 X 10 ⁻⁴	6.00 X 10 ⁻⁴	2.10 X 10 ⁻⁴	0.51 X 10 ⁻⁴
Weight	4 lbs.	4 lbs.	1 lb.	0.7 lb.	0.25 lb.
Enclosure	NEMA 4 or 4X	NEMA 4	NEMA 4	NEMA 13	NEMA 1
Environmental (All Transducers)					
Operating Temp -20 to 125°C	Shock 50 G's for 11 milliseconds		Vibration 5 to 2000 Hz @ 20 G's		

Table 1.4 Single-Turn Transducer Specifications

Multi-Turn Transducers

The following table contains the mechanical and environmental specifications for all AMCI multi-turn transducers that are compatible with the NX2A4C.

Specification	All HTT-20, HTT-400, HTT-425-F, & HTT-425-T	All HTT425 Motor Mount
Shaft Diameter	0.625"	0.250" or 10mm
Radial Shaft Loading	400 lbs. max.	40 lbs. max.
Axial Shaft Loading	200 lbs. max.	20 lbs. max.
Starting Torque	8 oz-in @ 25°C	1.5 oz-in @ 25°C
Moment of Inertia (oz-in-sec ²)	8.75 X 10 ⁻⁴	1.25 X 10 ⁻⁴
Weight	4 lbs.	4 lb.
Enclosure	HTT-20, 400: NEMA 4 HTT-425: NEMA 4X	NEMA 4 When properly installed.
Environmental (All Transducers)		
Operating Temp -20 to 125°C	Shock 50 G's for 11 milliseconds	
	Vibration 5 to 2000 Hz @ 20 G's	

Table 1.5 Multi-Turn Transducer Specifications

Other Compatible Transducers

In addition to AMCI transducers, the Nexus Resolver Interface directly supports transducers from Autotech Controls.

Supported Single-Turn Transducers

The supported Autotech models are:

- All SAC-RL100 Transducers (Size 40, NEMA 13)
- All E6R and E7R-RL101 Transducers. (Size 25, NEMA 13)
- SAC-RL101-010 Resolvers. (Size 11, NEMA 1)
- All SAC-RL220 Transducers (Size 40, NEMA 13, Redundant resolvers)

If your project is a new installation, or you can budget the cost of replacing the transducer, we *strongly* suggest using AMCI transducers. AMCI is the only company in the marketplace that designs and manufactures the resolvers used in its products. Our transducers and electronics are designed to work together, and will work for years to come when specified and installed properly.

If your project involves converting system originally designed for Autotech products, you will likely be able to use AMCI transducers without re-designing transducer mounting brackets. Table 1.6 lists Autotech transducer part numbers and the AMCI bolt-in replacements. Note that the resolvers used in AMCI transducers are for AMCI products, and all connectors are AMCI standard connectors, unless otherwise stated.

Autotech Transducers	AMCI Transducers	Comments
SAC-RL101-010	R11X-J10/7	Mechanically identical except that wires come out the back instead of the side.
E6R-RL101-000EF E7R-RL101-000EF	H25-FE	Bolt-in replacement. Shorter body length.
E6R-RL101-000ES E7R-RL101-000ES	H25-SE	Bolt-in replacement when servo mounting. Different bolt pattern on front, shorter body.
E6R-RL101-000SF E7R-RL101-000SF	H25-FS	Bolt-in replacement. Shorter body length, side connector in different location.
E6R-RL101-000SS E7R-RL101-000SS	H25-SS	Bolt-in replacement when servo mounting. Different bolt pattern on front, shorter body length, side connector in different location.
SAC-RL100-010	HT-400	Direct replacement.
SAC-RL100-M11	HT-400-1E	Bolt-in replacement, AMCI connector.
SAC-RL220-G010C, SAC-RL220-G010M	HTT-400-1	Bolt-in replacement, dual AMCI connectors with similar configuration to “-G101M”

Table 1.6 Autotech / AMCI Transducer Cross Reference

If you decide to use your Autotech transducers, you must change the *Resolver Type* parameter. If you set the Resolver Type to *Autotech*, then all of the transducers must be Autotech's. If you wish to bring both AMCI and Autotech single-turn transducers into one unit, you must set the Resolver Type parameter to *AMCI* and use an AMCI RM-3 Reference Module to connect the Autotech transducers.

NOTE

- 1) Due to differences in cable construction, AMCI does not support installations that use transducer cables supplied by Autotech Controls. When using Autotech transducers, you *must* use Belden 9873, or Belden 9730 if your cable length is over one hundred feet.
- 2) For more information on interfacing with Autotech transducer, see the AMCI's FAQ, “Using Transducers From Other Manufacturers”, posted on our website, www.amci.com.

Other Compatible Transducers (continued)

Supported Multi-Turn Transducers

The Autotech models supported are:

- All SAC-RL210-G128 Transducers. (Size 40, NEMA 13)

Autotech also manufactures SAC-RL210-G64 transducers which are not supported by AMCI.

If your project is a new installation, or you can budget the cost of replacing the transducer, we *strongly* suggest using AMCI transducers. Our transducers and electronics are designed to work together, and when specified and installed properly, will work for years to come.

If you decide to use your Autotech transducers, you must change the *Resolver Type* parameter. If you are only using multi-turn transducers and set the Resolver Type to *Autotech*, then all of the transducers must be Autotech's. You cannot bring an Autotech multi-turn and an AMCI multi-turn into the same NX2A4C.

NOTE

- 1) Due to differences in construction, AMCI does not support installations that use transducer cables supplied by Autotech Controls. When using Autotech transducers, you *must* use Belden 9731 cable.
- 2) When using Autotech transducers, only 10 bit resolution, (1,024 counts per turn), is supported. If you require a higher resolution in an Autotech style package, AMCI offers the HTT-400-180, which is a direct bolt-in replacement for the Autotech RL210. AMCI strongly suggests using the HTT-400-180 transducer instead of the Autotech RL210 in all new installations.
- 3) For more information on interfacing with Autotech transducer, see the AMCI's FAQ, "*Using Transducers From Other Manufacturers*", posted on our website, www.amci.com.

The remainder of this chapter introduces the programmable parameters of the NX2A4C. It also introduces programming concepts that you will use to configure it.

Programmable Parameters

You configure your unit by setting the values of its *Programmable Parameters*. These parameters are stored in nonvolatile memory. Therefore, there is no need to configure the NX2A4C after every power up. The non-volatile memory is an EEPROM that is rated for approximately 100,000 write cycles.

Resolver Type

The *Resolver Type* parameter allows you to use the NX2A4C with Autotech transducers. Unlike the other NX2A4C parameters, the Resolver Type parameter only exists on channel 1 because this parameter affects all channels.

- The default Resolver Type value is *AMCI*.

NOTE

- 1) AMCI has bolt-in replacements for most Autotech transducers and we strongly suggest using them in place of Autotech transducers whenever possible. See *Transducer Specifications* starting on page 11 for a list of bolt-in AMCI replacement transducers.
- 2) You can bring both AMCI and Autotech single-turn resolvers into one unit. Set the Resolver Type to *AMCI* and install a RM-3 to interface the Autotech transducers.
- 3) You can bring AMCI single-turn transducers into a NX2A4C with an Autotech multi-turn transducer. Set the Resolver Type to *Autotech* and install an RM-3 Reference Module to interface the AMCI transducers.
- 4) You cannot bring AMCI and Autotech multi-turn transducers into one unit.
- 5) For more information on interfacing with Autotech transducer, see the AMCI's FAQ, "*Using Transducers From Other Manufacturers*", posted on our website, www.amci.com.

Programmable Parameters (continued)

Transducer Fault Latch

Normally, a transducer fault is latched by the NX2A4C. Transducer faults can be caused by improper wiring, electrical noise, or a damaged transducer. When the unit detects a fault condition, it reports this fault over the network until a *Clear Errors* command is issued to it. If you have a situation where electrical noise is causing spurious transducer faults that you can safely ignore, you can disable the Transducer Fault Latch and force the NX2A4C to clear a fault as soon as possible. Note that an intermittent wiring problem may also cause spurious faults. If you want to reliably capture these transient faults, then you must leave the Transducer Fault Latch enabled because the NX2A4C can detect and clear transducer faults much faster than the network scans the unit.

- The default Transducer Fault Latch value is *enabled*.

Count Direction

This parameter sets the direction of transducer shaft rotation that increases the position count. *If the transducer is wired as specified in this manual* and the count direction is set to *positive*, the count will increase with clockwise rotation, (looking at the shaft). If the count direction is set to *negative*, the position count will increase with counter-clockwise rotation.

- The default Count Direction Value is *positive*.

NOTE

It is also possible to reverse the count direction by reversing wire pairs in the transducer cable. If you are designing the NX2A4C into an older system, it is possible that your drawings already have the pairs reversed and you may not need to set this parameter. Once the machine is setup, you can easily change this parameter if the position is increasing in the wrong direction.

Tachometer Response

This parameter sets the time between tachometer updates. It *only* affects the update time of the tachometer. It *does not* affect the update time of the position value, which is always 200 microseconds.

- The default Tachometer Response is 120 milliseconds.
- The Tachometer Response can be set to 120 or 24 milliseconds.

Transducer Type (Multi-turn Transducer Parameter Only)

The Transducer Type parameter exists for multi-turn transducers only. If a channel is programmed to be used with a single-turn transducer, then this parameter does not exist for that channel.

The Transducer Type parameter defines the type of multi-turn transducer attached to the channel. The NX2A4C needs this information in order to decode the multi-turn position correctly. This parameter also defines the values that can be programmed into the *Number of Turns* parameter.

- If the *Resolver Type* parameter is set to *AMCI*, the Transducer Type parameter can be set to 100, 180, 1,000, or 1,800.
- If the *Resolver Type* parameter is set to *Autotech*, the Transducer Type parameter must be set to 128.

Programmable Parameters (continued)

Number of Turns

(Multi-turn Transducer Parameter Only)

The maximum number of turns a multi-turn transducer can encode is fixed by the gearing inside of it. However, the NX2A4C has the ability to divide this maximum number of turns into smaller multi-turn cycles. The unit does this without loss of absolute position within the smaller cycle. An example of this feature is shown in figure 1.8. It shows how the 180 turn mechanical cycle of an HTT-20-180 can be broken down into three electronic cycles of sixty turns each. The 180 turn cycle could also be broken down into sixty cycles of three turns each.

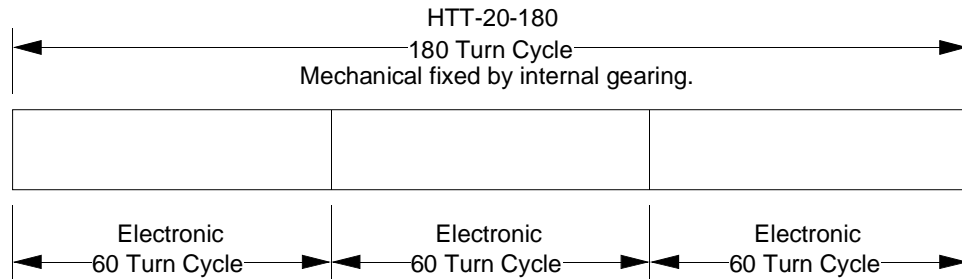

Figure 1.8 Programmable Number of Turns Example

The range of values for the Number of Turns parameter is dependent on the value of the *Transducer Type* parameter.

- **When Transducer Type = 100:** Number of Turns is programmable to 1, 2, 4, 5, 10, 20, 25, 50, or 100.
- **When Transducer Type = 180:** Number of Turns is programmable to 1, 2, 3, 4, 5, 6, 9, 10, 12, 15, 18, 20, 30, 36, 45, 60, 90, or 180.
- **When Transducer Type = 1,000:** Number of Turns is programmable to 10, 20, 40, 50, 100, 200, 250, 500, or 1,000.
- **When Transducer Type = 1,800:** Number of Turns is programmable to 10, 20, 30, 40, 50, 60, 90, 100, 120, 150, 180, 200, 300, 360, 450, 600, 900, or 1,800.
- **When Transducer Type = 128:** Number of Turns is programmable to 1, 2, 4, 8, 16, 32, 64, or 128.

Full Scale Count

The Full Scale Count specifies the total number of counts generated by the NX2A4C. In the case of single-turn transducers, it is the total number of counts over the one turn. In the case of multi-turn transducers, it is the total number of counts over the programmed Number of Turns.

For All Single-Turn Transducers

- The default Full Scale Count is 8,192.
- Range is 2 to 8,192. Setting the Full Scale Count to 360 gives 1 degree resolution.

For AMCI Multi-Turn Transducers

- Default value is (Number of Turns * 4,096) if Transducer Type equals 100 or 180
- Default value is (Number of Turns * 409.6) if Transducer Type equals 1,000 or 1,800
- Range is 2 to (Default Value)

For Autotech Multi-Turn Transducers (Transducer Type equals 128)

- Default value is (Number of Turns parameter) * 1,024
- Range is 2 to (Default Value)

Programmable Parameters (continued)

Linear Offset

The Linear Offset parameter changes the *range* of count values output by the unit and is used when the transducer position directly correlates to a linear measurement that does not start at zero. One such example is an overhead crane. Another example is a press shut height measurement.

As an example of how the Linear offset works, when the **Full Scale Count** is set to 1,500 and the Linear Offset is set to zero, the NX2A4C will output position values from 0 to 1,499. If the Linear Offset is changed to 100, then the unit will then output values from 100 to 1,599.

- The default Linear Offset is zero.
- For single-turn channels, the range of the Linear Offset is 0 to (32,767 – Full Scale Count).
- For multi-turn transducers, the range of the Linear Offset is 0 to 999,999.

A detailed example of using the Linear Offset, Full Scale Count, and Preset Value in a shut height application is given in **Appendix A**, starting on page 43.

Preset Value

The Preset Value parameter allows you to set the value of the position data to any count value within its range. The range of the count values is (Linear Offset) to (Linear Offset + (Full Scale Count - 1)). When the **Linear Offset** equals zero, this translates into 0 to (Full Scale Count - 1). Programming the Preset Value does not change the position data, it only sets the value that the position will change to when an *Apply Preset Command* is initiated.

- The default Preset Value is equal to the Linear Offset, which is typically zero. Programming the Linear Offset resets the Preset Value to equal it.
- The Preset Value range is (Linear Offset) to (Linear Offset + (Full Scale Count - 1)). When the Linear offset equals zero, this reduces to 0 to (Full Scale Count - 1)

A detailed example of using the Linear Offset, Full Scale Count, and Preset Value in a shut height application is given in **Appendix A**, starting on page 43.

Backplane Programming

A NX2A4C is programmed over the network through the input and output words assigned to it. Because these words are constantly updated, the unit implements a simple hand-shaking protocol to control when it accepts new programming data. This hand-shaking protocol is called a Programming Cycle.

Programming Cycle

A Programming cycle consists of six steps and is controlled by the *Transmit Bit* in the output data words and the *Acknowledge Bit* in the input data words.

- 1) Write the new programming data into the output data words with the Transmit Bit reset. This step insures that the correct data is in the output data words before the Programming Cycle begins.
- 2) Set the Transmit bit. A Programming Cycle is initiated when this bit makes a 0→1 transition.
- 3) Once the unit is done with the programming data, it will set any necessary error bits and the Acknowledge Bit in its input data words.
- 4) Once you see the Acknowledge Bit set, check for any errors. The error bits are only valid while the Acknowledge Bit is set.
- 5) Respond to any errors and reset the Transmit Bit.
- 6) The NX2A4C responds by resetting the Acknowledge Bit. The Programming Cycle is complete.

 **CAUTION** The EEPROM is guaranteed for approximately 100,000 write cycles. Therefore, continuously presetting the position or writing new parameters to the module should be avoided. If your application requires continuous presetting of the position, consider using your ladder logic program to calculate the offset.

CHAPTER 2

INSTALLATION

General Guidelines

When wiring any control system, these guidelines must be followed to help prevent electromagnetic interference and ground loops:

Wiring

- Transducer signals are generally low voltage, low power signals. If you are using A-B guidelines for cabling installation, treat the transducer cable as a Category 2 cable. It can be installed in conduit along with other low power cabling such as communication cables and low power ac/dc I/O lines. It cannot be installed in conduit with ac power lines or high power ac/dc I/O lines.
- Like all signal and communication cable, the transducer cable should be shielded. The shield must be grounded at one end only, typically at the input to the NX2A4C.
- If a junction must be made in the signal cable, treat the shield as a signal-carrying conductor. Do not connect the shield to ground at any junction box or the transducer.
- If the signal cable must cross power feed lines, it should do so at right angles.
- Route at least five feet from high voltage enclosures, or sources of “rf” radiation.

Grounding

- All ground connections must be permanent and continuous to provide a low-impedance path to earth ground for induced noise currents.
- The chassis of the NX2A4C must be connected to chassis ground through a grounding wire connected to the ground connection of the power supply connector.
- Any sensor or power supply that is attached to the NX2A4C must be connected to the same chassis ground as the unit to avoid ground loops.
- All isolation transformer secondary windings must be grounded to the same earth ground as the machine ground.

Surge Suppression

- Surge suppression devices should be placed across the coil of an inductive device to reduce the effects of high voltage transients (i.e., varistors, diodes, etc.). This includes any inductive load that is powered by the same supply used to power the NX2A4C or its sensors.

Mounting

- If mounting a NX2A4C on an enclosure door, do not rely on the hinge to make a good electrical connection between the door and the enclosure. A bonding wire from the door to the rest of the enclosure must be installed.

Required Power Supply

The NX2A4C draws its power from an external DC supply. The output voltage of the supply must be between 18 and 30 Vdc and it must be able to provide a minimum of twelve watts of power. This translates into 0.5A_{dc} @ 24V_{dc}. If you are using the brake input on the unit, the power supply can also be used to drive the input. The input will require a minimum of 10mA. Add this to the current requirements when sizing your power supply. A separate power supply can be used for the unit, or power can be drawn from a larger system supply.



If a separate supply is used, it should be mounted relatively close to the unit. If a system supply is used, this supply *must* not be used to switch large inductive loads such as relays or solenoids without proper surge suppression devices installed on these loads.



Mounting the NX2A4C

The next two pages show the NX2A4C in its DIN rail and panel mount configurations. The mounting kit, included with the unit, contains two DIN brackets, two panel brackets, and four #8 screws needed to attach your choice of brackets to the NX2A4C. Note that the enclosure is not sealed and the NX2A4C must be installed in an adequate enclosure to protect it from environmental contaminants.

DIN Rail Mounting

As shown in figure 2.1, the unit can be DIN rail mounted in two ways. The brackets accept EN 50 002 or EN 50 035 channel. Note that DIN channel is not included with the NX2A4C.

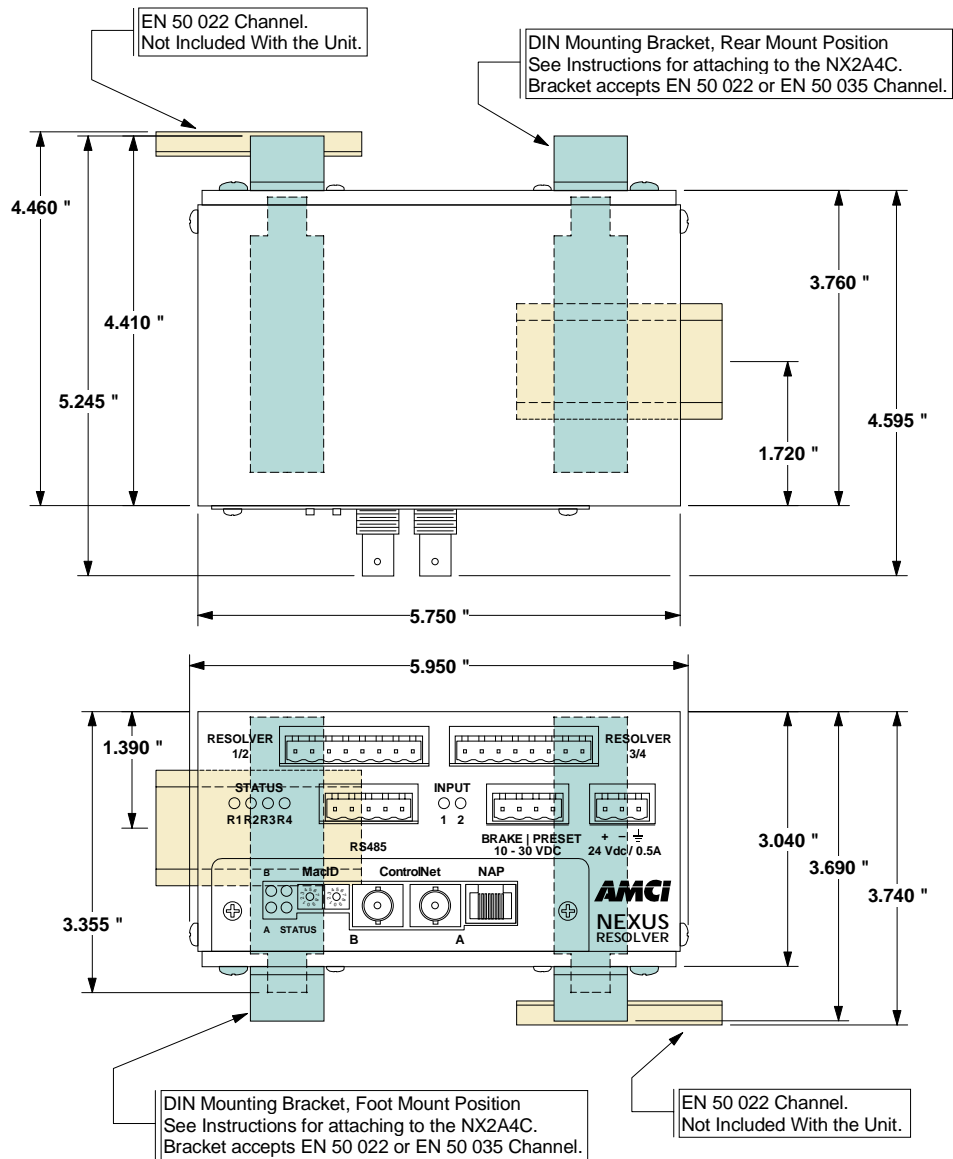

Figure 2.1 Dimensional Drawing - DIN Rail Mount

Mounting the NX2A4C (continued)

Panel Mounting

As shown in the figure below, the NX2A4C can be panel mounted in two ways. The mounting kit, included with the unit, contains the two panel brackets and four #8 screws needed to attach the brackets. The slots in the brackets for mounting the unit to the panel are made to accept #8 screws or bolts. The length of these screws or bolts depend on your application, and are not included with the unit.

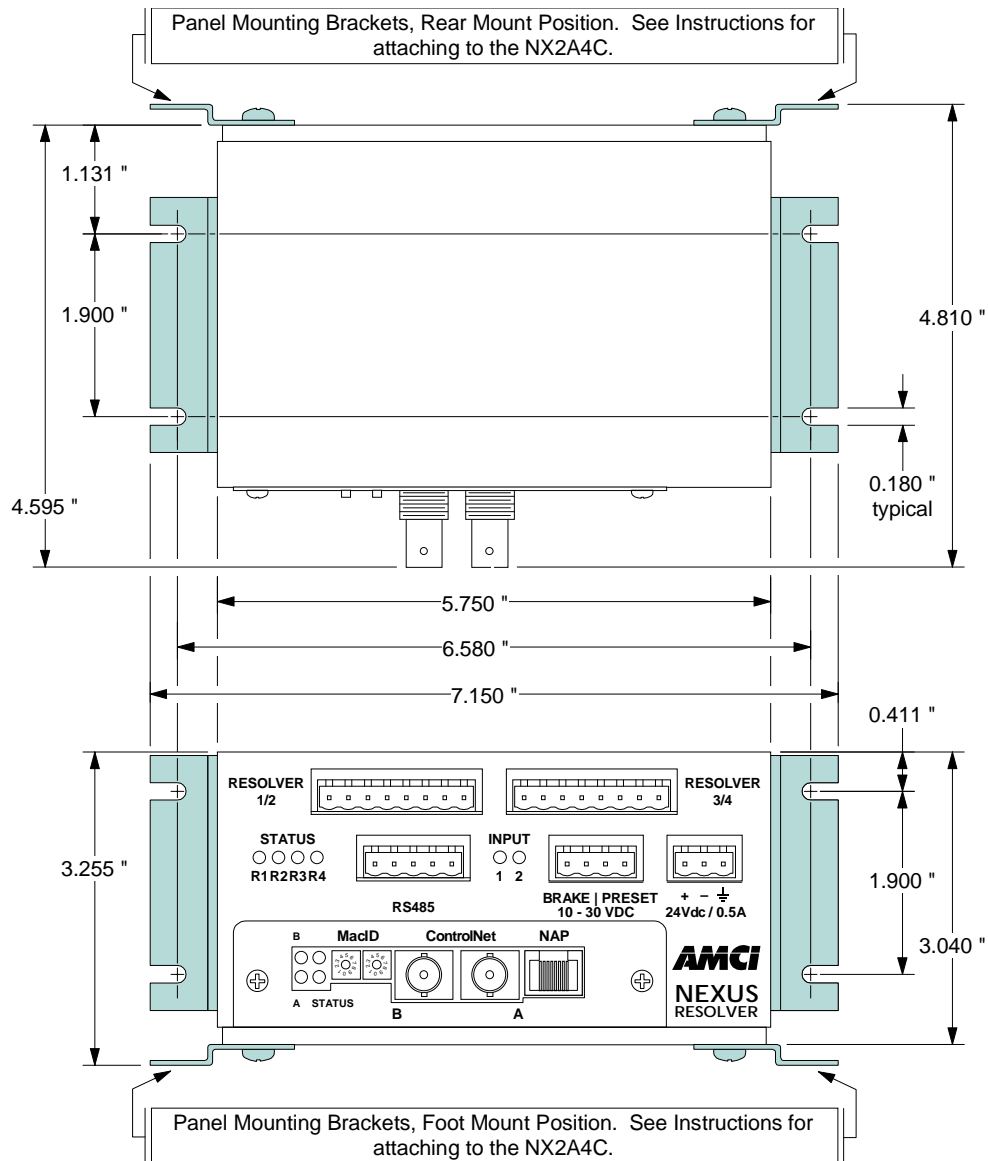

Figure 2.2 Dimensional Mount - Panel Mount

Mounting the NX2A4C (continued)

Attaching the DIN Brackets

Figure 2.3 shows how to install the DIN brackets so that the NX2A4C can be mounted on EN 50 022 or EN 50 035 rail. Note that the bottom view of the unit is shown. The rear view is similar and the brackets are installed in the same fashion.

- 1) Remove a DIN bracket, two #8 screws, and two #8 lock washers from the mounting kit bag.
- 2) Slide the DIN bracket onto the unit.
- 3) Install the two #8 screws and lock washers to secure the bracket on the unit.
- 4) Repeat on the other side.

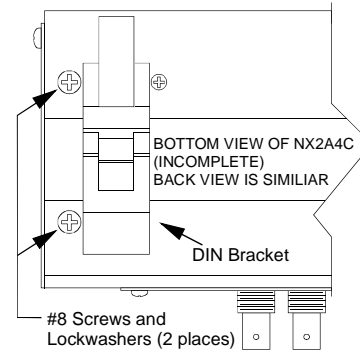
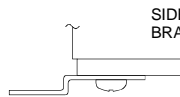

Figure 2.3 Installing DIN Brackets

Attaching the Panel Brackets

Figure 2.4 shows how to install the panel brackets so that the NX2A4C can be securely mounted to an enclosure. Note that the bottom view of the unit is shown. The rear view is similar and the brackets are installed in the same fashion.

- 1) Remove a panel bracket, two #8 screws, and two #8 lock washers from the mounting kit bag.
- 2) Position the panel bracket onto the unit.
- 3) Install the two #8 screws and lock washers to secure the bracket to the unit.
- 4) Repeat on the other side.



SIDE VIEW OF PANEL BRACKET INSTALLATION

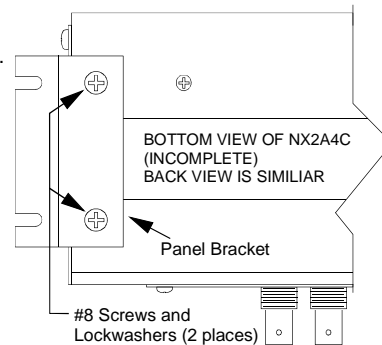

Figure 2.4 Installing Panel Brackets

Transducer Input Connectors

The Transducer Input Connectors, labeled “RESOLVER 1/2” and “RESOLVER 3/4” have eight contacts. The mating connectors are supplied with the NX2A4C and also come on any AMCI pre-assembled cable you may order. The AMCI part number for the mating connector is MS-8, while the Phoenix Contact part number is MSTB2.5/8-ST-5.08, order number 1757077. Figure 2.5 shows the connector pinout to industry standard wire designations. The single-turn pin out is shown on the left and multi-turn pin out on the right.

Single-Turn Pin Out				Multi-Turn Pin Out			
➤ A – First Resolver	BS3	8	□	FS4	➤ F – Fine Resolver		
➤ B – Second Resolver	BS4	7	□	FS1	➤ C – Course Resolver		
➤ R1/R2 – Reference Winding	AS3	6	□	CS4	➤ R1/R2 – Reference Winding		
➤ S1/S3 – COS Winding	AS4	5	□	CS3	➤ S1/S3 – COS Winding		
➤ S2/S4 – SIN Winding	AS1, AS2, BS1, BS2	4	□	CS1, CS2, FS2, FS3	➤ S2/S4 – SIN Winding		
	All Shields	3	□	All Shields			
	AR2, BR2	2	□	CR2, FR2			
	AR1, BR1	1	□	CR1, FR1			

Figure 2.5 Transducer Input Connector Pin Out

Transducer Connector Pin Outs

Figure 2.6 shows the connector pin outs for AMCI single and multi-turn transducers. Note that some AMCI transducers have integral cables or conduit connections. For a complete listing of AMCI transducers without connectors, refer to *AMCI Compatible Transducers*, starting on page 9.

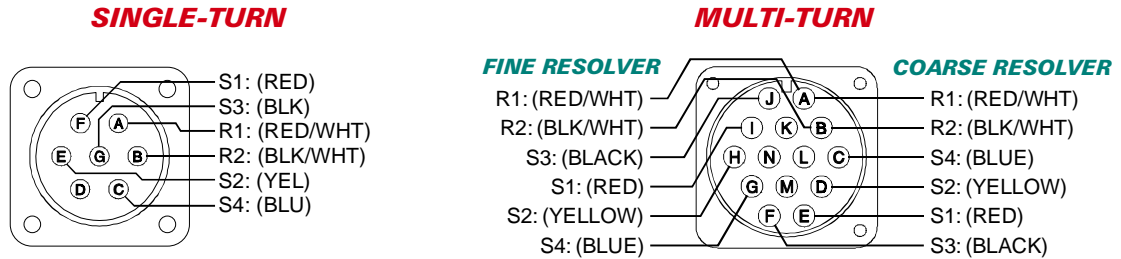

Figure 2.6 Transducer Connector Pin Outs

Transducer Cable Installation

Pre-assembled and tested cables are available from AMCI. The C1T-(x) cable is used to bring one single-turn transducer into the NX2A4C, while C2T-(x) cable is used to bring in two single-turn transducers. The CTT-(x) is used to bring in a multi-turn transducer. In all cases, (x) is the length in feet of the cable. Figures 2.7 through 2.9 are the wiring diagram of the AMCI cables.

NOTE

- 1) Resolvers are low voltage, low power devices. If you are using A-B guidelines for cabling installation, treat the transducer cable as a Category 2 cable. It can be installed in conduit along with other low power cabling such as communication cables and low power ac/dc I/O lines. It cannot be installed in conduit with ac power lines or high power ac/dc I/O lines.
- 2) The shields of the transducer cable must be grounded at the NX2A4C only! The **Shields** pins on the Transducer Input Connectors are brought to the earth ground pin on the power supply connector. When installing the cable, treat the shield as a signal carrying conductor. Do not connect the shield to ground at any junction box or the transducer. This will eliminate ground loops that could damage the NX2A4C.

C1T-(x) Wiring Diagram (One Single-Turn Transducer)

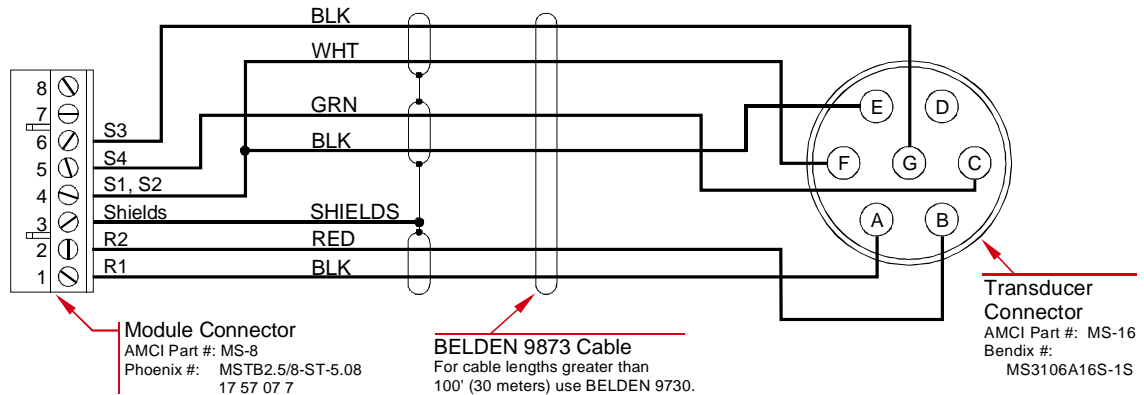

Figure 2.7 C1T-(x) Wiring Diagram



Transducer Cable Installation (continued)

C2T-(x) Wiring Diagram (Two Single-Turn Transducers)

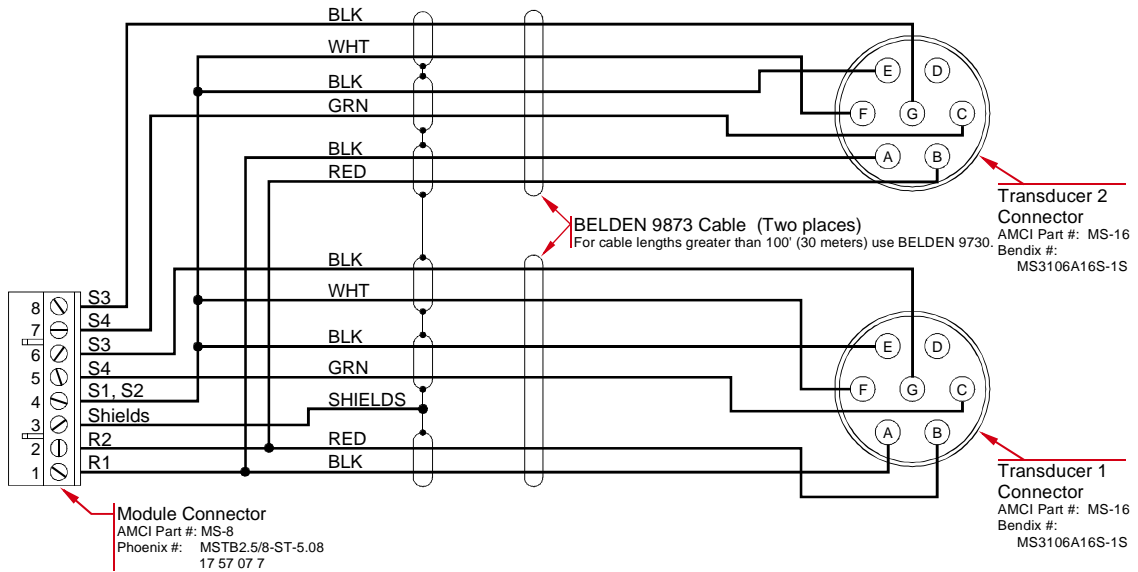

Figure 2.8 C2T-(x) Wiring Diagram

CTT-(x) Wiring Diagram (Multi-Turn Transducer)

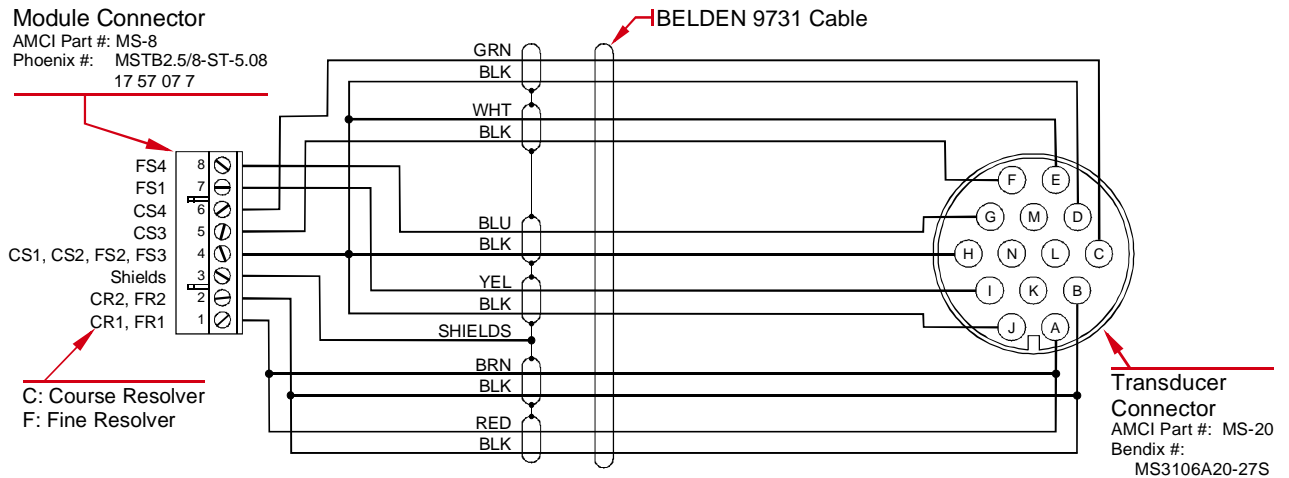

Figure 2.9 CTT-(x) Wiring Diagram

AMCI Transducer Mounting

All AMCI resolver based transducers are designed to operate in the industrial environment and therefore require little attention. However, there are some general guidelines that should be observed to ensure long life.

- ▶ Limit transducer shaft loading to the following maximums:

	Radial Load	Axial Load
All 0.625" Shafts	100 lbs. (445 N)	50 lbs. (222 N)
All 0.375" Shafts	30 lbs. (133 N)	15 lbs. (66.7 N)
All Other Shafts	1 lb. (4.45 N)	0.5 lb. (2.22 N)

Table 2.1 Transducer Bearing Loads

- ▶ Minimize shaft misalignment when direct coupling shafts. Even small misalignments produce large loading effects on front bearings. It is recommended that you use a flexible coupler whenever possible. A flexible coupler is *required* for all HT-6 transducers and R11 resolvers.

AMCI Transducer Outline Drawings

AMCI offers a broad line of resolver based transducers for use with the NX2A4C. (See [AMCI Compatible Transducers](#) starting on page 9.) Outline drawings for all of these transducers, and full spec sheets for our most popular transducers, are available on our website, www.amci.com. If you do not have internet access, contact AMCI and we will fax the information to you.

Autotech Transducer Installation

The manual is intended to be distributed on-line in PDF format, so file size is always a concern. If you require information on installing Autotech transducers, or using AMCI and Autotech transducers together, download the FAQ, “Using Transducers From Other Manufacturers”, posted on our website.

Even though Autotech transducers are usable, we strongly recommend using AMCI transducers whenever possible. Refer to the [Autotech / AMCI Transducer Cross Reference](#) table on page 12 for information on our recommended replacements for Autotech transducers. Remember that if you do decide to use Autotech transducers, you cannot use Autotech transducer cable. Due to differences in construction, you must use the cable types specified by AMCI.

Brake Input Wiring

If you are using the NX2A4C in a press control application, you can use the stop time monitor of the unit to measure press braking time. See [Stop Time Monitoring](#) on page 8 for information on how the stop time monitor works. If your application is not press control related, you can disable the stop time monitor by not wiring the Brake Input.

Input Connector

Figure 2.10 shows the pin out and simplified schematic of the Brake Input. The schematic of the Preset Input is identical. Note that the Preset Input is not presently implemented on the NX2A4C. Applying power to the Preset Input will light its LED, but the unit ignores the input.

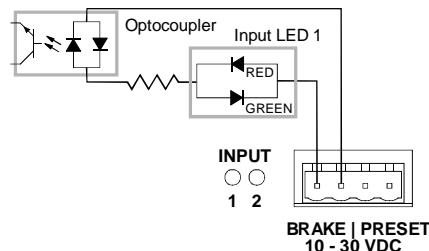

Figure 2.10 Brake Input Schematic

Brake Input Wiring (continued)

Connector Wiring

Figure 2.11 below is an example of how to wire the Brake Input. The same power supply that powers the NX2A4C can be used to power the Brake Input. The figure assumes that a relay is used to trigger the input. A normally open contact is shown because an on-to-off (1 → 0) transition is needed to trigger the stop time monitoring cycle. In typical press control configurations, power must be applied to the brake clutch before the crankshaft can rotate. In this case, the normally open contact is closed and power is applied to the input. When power is removed from the clutch to apply the brake, the contact opens and the unit sees the on-to-off transition needed to start the stop time monitoring cycle.

NOTE Shielded cable should be used to help with signal noise immunity. Treat the shield as a signal carrying conductor and ground it only at the power supply *or* NX2A4C. Do not ground the shield at any junction box or at both the power supply and unit. This will help eliminate potential ground loops in your system.

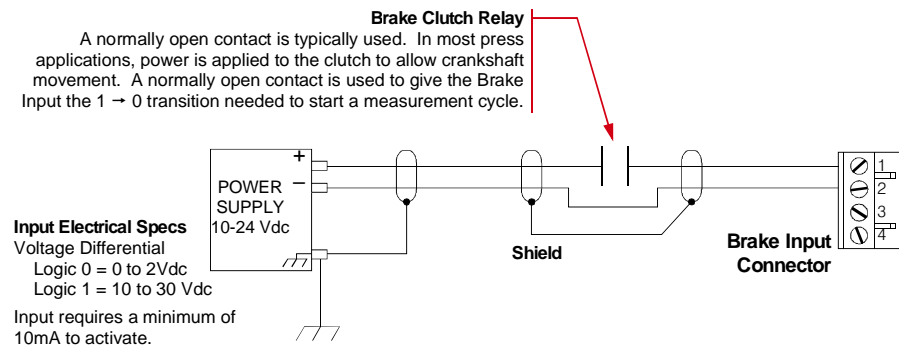

Figure 2.11 Brake Input Wiring

Connecting to the ControlNet Network

Setting the Node Address

The two switches labeled “MacID” are used to set the node address of the NX2A4C. As shown in figure 2.12, the left switch is used to set the low digit of the address and the right switch is used to set the high digit. Therefore, the address reads right to left, not left to right.

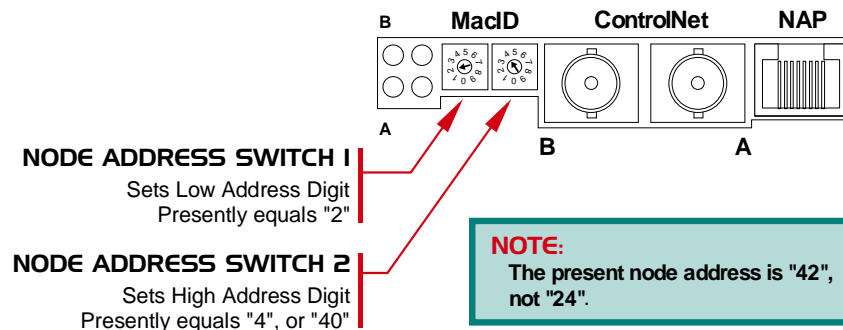

Figure 2.12 Node Address Switches

Physically Attaching to the Network

The Nexus Resolver Interface appears as a standard node on the ControlNet network. Follow Allen-Bradley guidelines when attaching the NX2A4C to the network. The “A” network connector is typically used. The “B” connector is usually used on redundant systems only. Refer to Allen-Bradley’s *ControlNet Cable System Planning and Installation Manual*, publication 1786-6.2.1 for more information on attaching the network to the unit.

Connecting Power

An external 18 to 30Vdc supply, typically 24Vdc, is required to power the NX2A4C. Power consumption is twelve watts. This translates into 0.5A @ 24Vdc. The power supply used to power the unit can also be used to power the Brake Input if your application requires it.

Figure 2.13 shows how to connect an external isolated supply to the NX2A4C.

NOTE ⚠ The grounding wire shown in the figure from the NX2A4C to the ground bus is *required*. The shield pins of the Transducer Input Connectors are attached to this pin and a heavy gauge drain wire is required to properly shield the resolver signals. Do not rely on mounting hardware to properly ground the unit. If the NX2A4C is panel mounted, paint and surface dirt may interfere with a proper electrical connection. If the unit is DIN rail mounted, the unit is completely isolated by the plastic brackets.

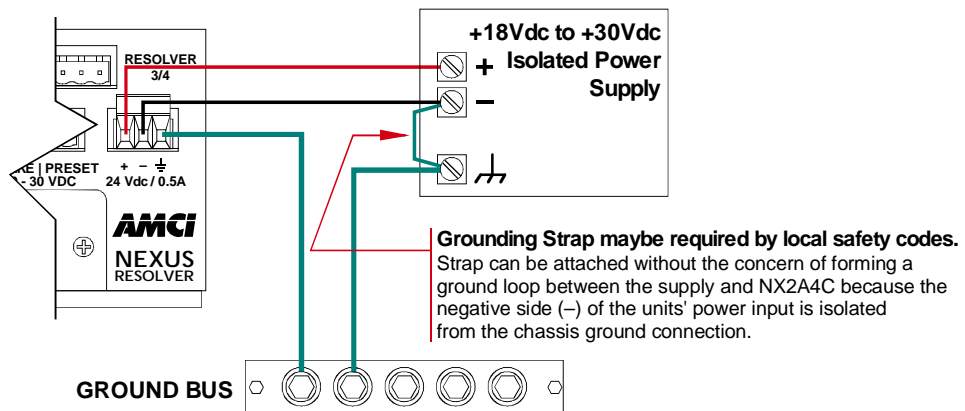

Figure 2.13 NX2A4C DC Power Connections



Notes

CONTROLNET CONFIGURATION

Getting the EDS and Icon Files

If this is your first time using a NX2A4C, then you will probably need the Electronic Data Sheet (EDS) and icon files when configuring the unit in A-B's RSNetWorx software. These files are available on our website, www.amci.com. You'll find them as a single ZIP file in our *Document Retrieval* section. Once you download them, un-zip the file to either your hard drive or a floppy disk.

Before You Begin

The instructions for configuring your ControlNet software assumes that the NX2A4C has its node address already set, that it is connected to the network, and it is powered. If you have not already done this, refer to [Connecting to the ControlNet Network](#) starting on page 24 for information on connecting the NX2A4C to the network.

Adding a NX2A4C to a SLC 500 System

As of this manual's release, the NX2A4C has not been tested with a 1747-SCNR scanner module. Even though AMCI doesn't anticipate any problems, we decided not to include un-tested information. It is possible that a FAQ or revision of this manual has been released since you received one, so you are encouraged to check our website, www.amci.com, for additional information on configuring a SLC 500 system.

Adding a NX2A4C to a ControlLogix System

These instructions are generalized to keep them usable over changing RS software versions from Allen-Bradley. These instructions were tested against versions 6.01 and 7.00 of *RSLogix 5000* along with versions 2.25 and 3.00 of *RSNetWorx for ControlNet*, and should work with all RS software versions.

When adding a NX2A4C to a ControlLogix system, you have to specify it in two RS software packages, *RSLogix 5000* and *RSNetWorx for ControlNet*. In *RSLogix 5000*, you specify the node address for the unit, its data type, and the location and number of I/O data words. In *RSNetWorx*, you add the EDS file to the database and specify the node address.

NOTE

When you update one of your RS software packages from A-B, you may be required to update other packages to keep the system operating. If you update software and have problems communicating with the network, refer to A-B documentation to verify that all of your software packages are at the correct versions before proceeding.

RSLogix 5000 Setup

- 1) Start *RSLogix 5000* and either open an existing project or create a new one.
- 2) The *Controller Organizer* pane should be open on the left side. If it's not, press **ALT+O** to open it.
- 3) If it's a new project, you must first define the ControlNet adapter by right clicking on the *I/O Configuration* folder and selecting **New Module...**
- 4) Once the ControlNet adapter is configured, right click on it and click on **New Module...**

Adding a NX2A4C to a ControlLogix System (continued)

RSLogix 5000 Setup (continued)

- 5) Define the NX2A4C as a generic CONTROLNET-MODULE. Click **OK** and define the properties as follows:

Name:	Your Choice	
Description:	Your Choice	
Comm Format:	Data-INT	
Node:	Set it to the same value as the <i>Node Address</i> of the NX2A4C.	
	Assembly Instance	Size
Input:	100	23 [†]
Output:	150	10 [‡]
Configuration:	110	0

[†] If you are not using all of the input channels and you are not using the brake monitoring feature, then you can decrease the number of scanned input words from its default of twenty-three. Refer to *ControlLogix Input Data Format* on page 35 to determine the number of words needed. Remember that the numbering of the words begins at zero, so add one to the number of the last word that you need before entering it in the properties table. Even though you can change the number of words, AMCI suggests leaving it at its default of twenty-three to help keep your setup compatible with potential future releases of the NX2A4C.

[‡] If you are only using single-turn transducers, then you can decrease the number of output words from ten to eight. However, AMCI suggests leaving the number of words at its default of ten to help keep your setup compatible with potential future releases of the NX2A4C.

- 6) Click **Next>** and define the RPI. The minimum value is 5.0 milliseconds.
 7) Click **Finish**.
 8) Save the project.
 9) Download the new configuration to the processor.

RSNetWorx Setup

- 1) Start RSNetWorx for ControlNet and either open an existing project or create a new one.
- 2) If this is the first time using a NX2A4C, you will probably need to register the EDS file. If you haven't downloaded the EDS and icon file from our website, refer to *Getting the EDS and Icon Files* on page 27 for instructions. Once you have the EDS file, register the NX2A4C by clicking on the **Tools** menu, followed by **EDS Wizard...** and following the instructions. The name of the EDS file is **NX2A4C_r01.eds**.
- 3) Go Online. RSNetWorx will scan the ControlNet network and should discover the NX2A4C at the node address you set with the rotary switches and specified in the RSLogix 5000 software.
- 4) Click on the Enable Edits checkbox and then save the project.

At this point, check the *ControlNet Status* LED's on the unit. The *Unit Status* and *Adapter Status* LED's should both be on solid green. The Channel A/B Status LED's should also be on solid green if they have a physical network connection. No LED's should be blinking red.

If the status LED's are OK, bring up the RSLogix 5000 software. Select the **Logic** menu, followed by **Monitor Tags**. The data associated with the NX2A4C is available under the name you chose when configuring it. For example, if you chose a name of "NexusNode" in step 5 of the RSLogix 5000 Setup, the input data is available under *NexusNode:I→NexusNode:I.Data→NexusNode:I.Data[0-22]*. Similarly, the output data is available under the *NexusNode:O* tree.

Adding a NX2A4C to a PLC-5 System

These instructions are generalized to keep them usable over changing RS software versions from Allen-Bradley. These instructions were tested against versions 2.25 and 3.00 of *RSNetWorx for ControlNet* and should work with all RS software versions.

When adding a NX2A4C to a PLC-5 system, you have to specify the unit in the *RSNetWorx for ControlNet* software. In *RSNetWorx*, you add the EDS file to the database and specify the node address. After that, you modify the scanlist to communicate with the unit.

NOTE

When you update one of your RS software packages from A-B, you may be required to update other packages to keep the system operating. If you update software and have any problems, refer to A-B documentation to verify that your software packages are all at the correct versions before proceeding.

RSNetworx Setup

- 1) After connecting the NX2A4C to the network and applying power, start *RSNetworx* and either open an existing project or create a new one.
- 2) If this is the first time using a NX2A4C, you will probably need to register the EDS file. If you haven't downloaded the EDS and icon file from our website, refer to [Getting the EDS and Icon Files](#) on page 27 for instructions. Once you have the EDS file, register the NX2A4C by clicking on the **Tools** menu, followed by **EDS Wizard...** and following the instructions. The name of the EDS file is **NX2A4C_r01.eds**.
- 3) Click the icon to go online. The network is searched, and the NX2A4C will appear as an "Extra device" at the node selected with the rotary switches.
- 4) Click the **Enable Edits** checkbox and choose "Use online data (upload)". Click **OK**. At this point, you can right click on the NX2A4C icon and select **Properties** from the pop-up menu. In the properties window, you can change the name associated with the unit and add a description.
- 5) Go offline by clicking the icon and save the changes to the project.
- 6) Click the **Enable Edits** checkbox and then right click on the PLC-5 icon. Click on *Scanlist Configuration* in the pop-up menu.
- 7) In the Device Name column, right click on the name of the unit, (NX2A4C by default), and click on **Insert Connection** in the pop-up menu. The *Connection Properties* window appears on the screen. A sample *Connection Properties* window is shown in figure 3.1
- 8) If needed, set the Input Size and Input Address of the *Data Input File*. This file, N9 in the figure, resides in the PLC-5 and is used by all of the ControlNet nodes. Therefore, it must be large enough to hold all of the input data on the network. If you are not using all of the input channels and you are not using the brake monitoring feature, then you can decrease the number of scanned input words from its default of twenty-one. Refer to [PLC-5 Input Data Format](#) on page 36 to determine the number of words needed. Remember that the numbering of the words begins at zero, so add one to the number of the last word that you need before entering it in the properties table. Even though you can change the number of words, AMCI suggests leaving it at its default of twenty-one to help keep your setup compatible with potential future releases of the NX2A4C.

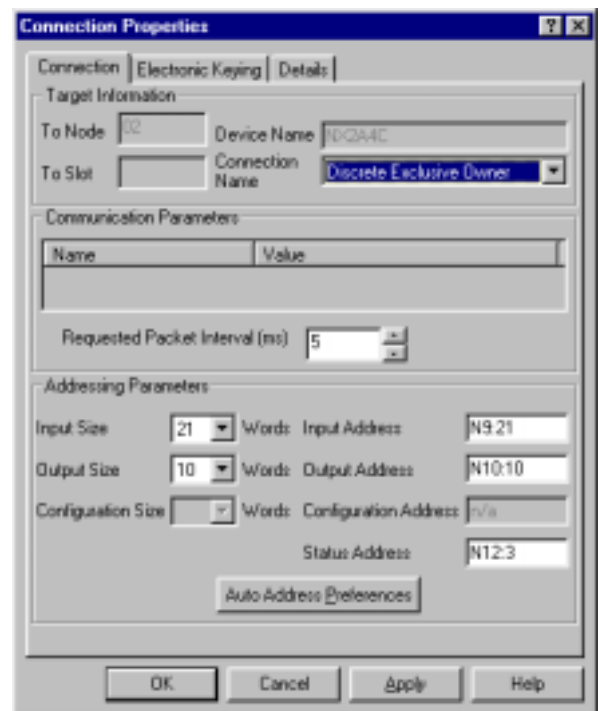



Figure 3.1 Scanlist Configuration Screen

Adding a NX2A4C to a PLC-5 System (continued)**RSNetworkx Setup (continued)**

- 9) If needed, set the Output Size and Output Address of the *Data Output File*. This file, N10 in the figure, resides in the PLC-5 and is used by all of the ControlNet nodes. Therefore, it must be large enough to hold all of the output data on the network. If you are only using single-turn transducers, then you can decrease the number of output words from ten to eight. However, AMCI suggests leaving the number of words at its default of ten to help keep your setup compatible with potential future releases of the NX2A4C.
- 10) Set the Request Packet Interval time. This has a minimum acceptable value of five milliseconds.
- 11) Click **OK** to close the *Connection Properties* window. In the *Scanlist Configuration* window, save the changes and close the window.
- 12) Click the  icon to go online. Click on the **Network** menu and then click **Download to Network**.

At this point, check the **ControlNet Status** LED's on the unit. The *Unit Status* and *Adapter Status* LED's should both be on solid green. The Channel A/B Status LED's should also be on solid green if they have a physical network connection. No LED's should be blinking red.

If the status LED's are OK, bring up the RSLogix 5 software. The input data will be at the address you specified when configuring the Scanlist Properties. (Step 8 above.)

DATA FORMAT & PROGRAMMING

Output Data Words

The ten output data words are written from the ControlNet controller to the NX2A4C. They are used to program the unit and preset transducer position values. Table 4.1 shows the two formats of the output data. One format is used to program single-turn transducer channels, the other format is used for multi-turn transducer channels. In either case, the bits in the *Control Word*, determines how the rest of the data is interpreted.

Word #	Single-Turn Programming Data	Multi-Turn Programming Data
0	Control Word	Control Word
1	Configuration Word	Configuration Word
2	0000h	Upper 3 Digits of Full Scale Count
3	Full Scale Count	Lower 3 Digits of Full Scale Count
4	0000h	Upper 3 Digits of Linear Offset
5	Linear Offset	Lower 3 Digits of Linear Offset
6	0000h	Upper 4 Digits of Preset Value
7	Preset Value	Lower 3 Digits of Preset Value
8	0000h	Transducer Type
9	0000h	Number of Turns

Table 4.1 Programming Data Format

NOTE

- 1) All data words that are defined as zero in the table above are reserved for future expansion. These words must equal zero when you initiate a Programming Cycle to the NX2A4C.
- 2) If you are using the NX2A4C to interface with single-turn transducers only, when you configure the network as described in chapter 3, you can set the number of data words to eight instead of ten. The NX2A4C automatically fills in any data word that is not transmitted to it with a value of zero, so the programming block will still work correctly.

Multi-Word Format

When programming a multi-turn channel, the Full Scale Count, Linear Offset, and Preset Values can exceed 32,767. Therefore, these three parameters each require two words to hold their data. The lower three digits of the value, (ones, tens, and hundreds), are stored in the second word. The “thousands” digits and above are stored in the first word. For example, a Preset Value of 123,456 would be stored as 123 in the first word and 456 in the second.

Control Word Format

Figure 4.1 shows the location of the Control Word bits used to preset positions and program channels.

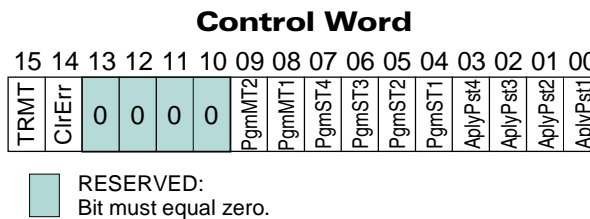

Figure 4.1 Control Word Bits

ApyPV1: Apply Preset Value, Channel 1, Bit 00. Set this bit to preset the position value of transducer 1 to the programmed Preset Value. This bit presets the first transducer, either the first single-turn or the first multi-turn transducer.

Output Data Words (continued)**Control Word Format (continued)**

ApyPV2: Apply Preset Value, Channel 2, Bit 01. Set this bit to preset the position value of the single-turn transducer on resolver input 2 to the programmed Preset Value. If resolver inputs 1 and 2 are configured to accept a multi-turn transducer, then this bit is not used.

ApyPV3: Apply Preset Value, Channel 3, Bit 02. Depending on how the NX2A4C is configured, setting this bit will preset either the third single-turn channel, (transducer on resolver input 3) or the second multi-turn channel, (transducer on resolver inputs 3&4).

ApyPV4: Apply Preset Value, Channel 4, Bit 03. Set this bit to preset the position value of the single-turn transducer on resolver input 4 to the programmed Preset Value. If resolver inputs 3 and 4 are configured to accept a multi-turn transducer, then this bit is not used.

NOTE 

Applying the Preset Value is the last action taken during a Programming Cycle, so you can program a new Preset Value and apply it in one cycle.

PgmST1: Program Single-Turn Channel 1, Bit 04. Set this bit to configure resolver input 1 to accept a single-turn transducer and set its parameters to the values specified in the rest of the Output Data Words. Note that you must program Resolver Input 1 as a single-turn channel if you are going to use the stop time functionality of the NX2A4C unit.

PgmST2: Program Single-Turn Channel 2, Bit 05. Set this bit to configure resolver input 2 to accept a single-turn transducer and set its parameters to the values specified in the rest of the Output Data Words.

PgmST3: Program Single-Turn Channel 3, Bit 06. Set this bit to configure resolver input 3 to accept a single-turn transducer and set its parameters to the values specified in the rest of the Output Data Words.

PgmST4: Program Single-Turn Channel 4, Bit 07. Set this bit to configure resolver input 4 to accept a single-turn transducer and set its parameters to the values specified in the rest of the Output Data Words.

PgmMT1: Program Multi-Turn Channel 1, Bit 08. Set this bit to configure resolver inputs 1 and 2 to accept a multi-turn transducer and set its parameters to the values specified in the rest of the Output Data Words.

PgmMT2: Program Multi-Turn Channel 2, Bit 09. Set this bit to configure resolver inputs 3 and 4 to accept a multi-turn transducer and set its parameters to the values specified in the rest of the Output Data Words.

NOTE 

- 1) Only one of the six program channel bits, (bits 04-09) can be set during a Programming Cycle. You can leave them all zeros if you are only presetting a channel with the cycle.
- 2) If you program two resolver inputs to act as a multi-turn channel and then later program either of those resolver inputs as a single-turn channel, the inputs will be re-configured as two single-turn channels. The multi-turn data will be replaced with two sets of single-turn data. Both of the new single-turn channels will have their parameters set to the values specified by the command that re-configured the inputs.

ClrErr: Clear Errors, Bit 14. Set this bit to clear any programming errors and latched transducer faults. This bit is the first one acted upon, so you can clear an error and perform an operation that depends on the error being cleared in one programming cycle. An example of this is clearing a transducer fault and presetting the transducer in one operation. (The NX2A4C requires that the transducer not be in a fault condition before it can be preset.)

TRMT: Transmit Bit, Bit 15. A 0 → 1 transition on this bit initiates a Programming Cycle. All of the data in the output words is ignored until this bit transitions. Also, the data in the words must be correct before this bit changes state.

DATA FORMAT

Output Data Words (continued)

Configuration Word Format

Figure 4.2 shows the bits in the Configuration Word used to program four parameters. If you are programming channel 1, either as a single-turn or multi-turn, then the Resolver Type parameter is also available. If you are using Autotech transducers, you must program channel 1 first in order to program the other channels correctly.

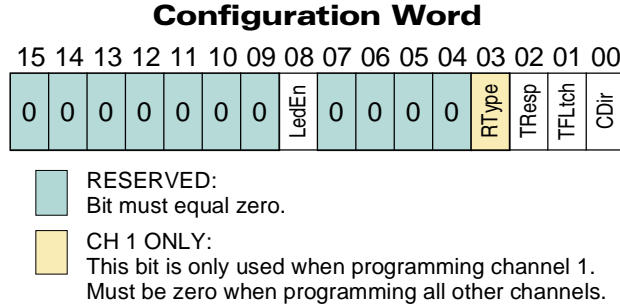

Figure 4.2 Configuration Word Bits

- CDir: Count Direction, Bit 00.** This bit is used to program the Count Direction parameter for the channel. When reset, the Count Direction is set to *positive*. That is, the position count will increase with clockwise rotation *if the transducer cable is wired as specified in this manual*. When this bit is set, the Count direction is set to *negative*.
- TFLtch: Transducer Fault Latch, Bit 01.** When reset, the Transducer Fault Latch for the channel is enabled and all transient transducer faults will be latched. When set, the Transducer Fault Latch is disabled and transducer faults will clear themselves as soon as a working transducer is properly attached to the NX2A4C.
- TResp: Tachometer Response, Bit 02.** When reset, the Tachometer Response parameter for the channel is set to 120 milliseconds. When set, the Tachometer Response is set to 24 milliseconds.
- RType: Resolver Type, Bit 03.** *This bit is only used when programming channel 1. This bit must be reset when programming any other channel.* When programming channel 1, reset this bit to program the Resolver Type parameter to *AMCI*. Set this bit to program the Resolver Type to *Autotech*.
- LedEn: LED Enable, Bit 08.** When reset, the corresponding *Unit and Resolver Status LED* is disabled and will not come on. When the bit is set, the corresponding LED is enabled and shows the channels status. If the channel is configured as a multi-turn channel, both of the associated LED's are affected. See page 6 for a description of the Module and Resolver Status LED's

Single-Turn Parameter Ranges and Factory Default Values

Parameter	Range	Default
Count Direction	Positive / Negative	Positive
Transducer Fault Latch	Enabled / Disabled	Enabled
Tach Response	24 or 120 milliseconds	120 milliseconds
Resolver Type	AMCI / Autotech	AMCI
Full Scale Count	2 to 8,192 inclusive	8,192
Linear Offset	0 to (32,767 – Full Scale Count)	0
Preset Value	Linear Offset to (Linear Offset + (Full Scale Count - 1))	0

Table 4.2 Single-Turn Parameter Ranges and Defaults

Output Data Words (continued)**Multi-Turn Parameter Ranges and Factory Default Values**

Parameter	Range	Default
Count Direction	Positive / Negative	Positive
Transducer Fault Latch	Enabled / Disabled	Enabled
Tach Response	24 or 120 milliseconds	120 milliseconds
Resolver Type	AMCI / Autotech	AMCI
Transducer Type	100, 180, 1,000, 1,800, 128	100
Number of Turns	100 Turn: 1, 2, 4, 5, 10, 20, 25, 50, and 100 180 Turn: 1, 2, 3, 4, 5, 6, 9, 10, 12, 15, 18, 20, 30, 36, 45, 60, 90, and 180 1,000 Turn: (Any 100 turn value) * 10 1,800 Turn: (Any 180 turn value) * 10 128 Turn: 1, 2, 4, 8, 16, 32, 64, 128	100
Full Scale Count	2 to (# of Turns * 4,096) if AMCI 100 or 180 Turn 2 to (# of Turns * 409.6) if AMCI 1,000 or 1,800 Turn 2 to (# of Turns * 1,024) if Autotech 128 Turn	409,600
Linear Offset	0 to 999,999	0
Preset Value	Linear Offset to (Linear Offset + (Full Scale Count - 1))	0

Table 4.3 Multi-Turn Parameter Ranges and Defaults

DATA FORMAT

ControlLogix Input Data Format

Table 4.4 shows the format of the input data words transferred from a NX2A4C to a ControlLogix master. Note that the data format in a ControlLogix system is different than the data format in a PLC-5 system, which is shown in table 4.5 on the next page. In a ControlLogix system, the data stream is padded with two leading data words of zero. Consequently, a transfer to a ControlLogix master requires that you set the number of input data to twenty-three and the data is shifted down by two words when compared to that of a PLC-5 system.



NOTE All of the input data words that are defined as zero in the table to the right are reserved for future expansion. When you configure the network as described in the *Adding a NX2A4C to a ControlLogix System* section of chapter 3 starting on page 27, you can set the number of data words to only those you need for your application. For example, if you are using only one multi-turn resolver, you can set the number of input data words to six. However, if you ever need to replace the unit at a later date, you may need to adjust the number of words at that time to get the system operating again.

Word #	ControlLogix System	
	Single-Turn Data	Multi-Turn Data
0	0000h	0000h
1	0000h	0000h
2	Ch 1 Status	Ch 1 Status
3	0000h	Ch 1 Upper 4 Position Digits
4	Ch 1 Position	Ch 1 Lower 3 Position Digits
5	Ch 1 Tachometer	Ch 1 Tachometer
6	Ch 2 Status	0000h
7	0000h	0000h
8	Ch 2 Position	0000h
9	Ch 2 Tachometer	0000h
10	Ch 3 Status	Ch 2 Status
11	0000h	Ch 2 Upper 4 Position Digits
12	Ch 3 Position	Ch 2 Lower 3 Position Digits
13	Ch 3 Tachometer	Ch 2 Tachometer
14	Ch 4 Status	0000h
15	0000h	0000h
16	Ch 4 Position	0000h
17	Ch 4 Tachometer	0000h
18	Stop Time	0000h
19	Brake Applied Position	0000h
20	0000h	0000h
21	0000h	0000h
22	0000h	0000h

Table 4.4 ControlLogix Input Data Format

Data Blocks

The input data is broken down into two data blocks. Words 2 – 9 are data block A, words 10 – 17 are data block B. If you are not bringing both single-turn and multi-turn transducers into the unit, then you don't have to worry about data blocks. Just refer to the proper column to determine the data layout. If you are bringing single-turn and multi-turn transducers into one NX2A4C, then the format of the data block depends on how the channels are configured. If channels one and two are configured as single-turns and channels three and four are configured as a multi-turn, then the format of data block A is from the single-turn column and the format of data block B is from the multi-turn column.

Multi-Word Format

A multi-turn position value can exceed 32,767. Therefore, it requires two words to hold its data. The lower three digits of the value are stored in the second word. The “thousands” digits and above are stored in the first word. For example, a value of 123,456 is be stored as 123 in the first word and 456 in the second.

PLC-5 Input Data Format

Table 4.5 shows the format of the input data words transferred from a NX2A4C to a PLC-5 master. Note that the data format in these systems is different than the data format in a ControlLogix system, which is shown in figure 4.4 on the previous page. In a ControlLogix system, the data stream is padded with two leading data words of zero. Consequently, a transfer to a ControlLogix master requires that you set the number of input data to twenty-three and the data is shifted down by two words when compared to that of a PLC-5 system.

NOTE

All of the input data words that are defined as zero in the table to the right are reserved for future expansion. When you configure the network as described in the *Adding a NX2A4C to a PLC-5 System* section of chapter 3 starting on page 29, you can set the number of data words to only those you need for your application. For example, if you are using only one multi-turn resolver, you can set the number of input data words to four. However, if you ever need to replace the unit at a later date, you may need to adjust the number of words at that time to get the system operating again.

Word #	PLC-5 System		
	Single-Turn Data	Multi-Turn Data	
0	Ch 1 Status	Ch 1 Status	Data Block A
1	0000h	Ch 1 Upper 4 Position Digits	
2	Ch 1 Position	Ch 1 Lower 3 Position Digits	
3	Ch 1 Tachometer	Ch 1 Tachometer	
4	Ch 2 Status	0000h	
5	0000h	0000h	
6	Ch 2 Position	0000h	
7	Ch 2 Tachometer	0000h	Data Block B
8	Ch 3 Status	Ch 2 Status	
9	0000h	Ch 2 Upper 4 Position Digits	
10	Ch 3 Position	Ch 2 Lower 3 Position Digits	
11	Ch 3 Tachometer	Ch 2 Tachometer	
12	Ch 4 Status	0000h	
13	0000h	0000h	
14	Ch 4 Position	0000h	
15	Ch 4 Tachometer	0000h	
16	Stop Time	0000h	
17	Brake Applied Position	0000h	
18	0000h	0000h	
19	0000h	0000h	
20	0000h	0000h	

Table 4.5 PLC-5 / SLC 500 Input Data Format

Data Blocks

The input data is broken down into two data blocks. Words 0 – 7 are data block A, words 8 – 15 are data block B. If you are not bringing both single-turn and multi-turn transducers into the unit, then you don't have to worry about data blocks. Just refer to the proper column to determine the data layout. If you are bringing single-turn and multi-turn transducers into one NX2A4C, then the format of the data block depends on how the channels are configured. If channels one and two are configured as single-turns and channels three and four are configured as a multi-turn, then the format of data block A is from the single-turn column and the format of data block B is from the multi-turn column.

Multi-Word Format

A multi-turn position value can exceed 32,767. Therefore, it requires two words to hold its data. The lower three digits of the value are stored in the second word. The “thousands” digits and above are stored in the first word. For example, a value of 123,456 is stored as 123 in the first word and 456 in the second.

Status Word Format

The input data of each single-turn or multi-turn channel has a *Status Word* that contains programming error bits, bits that give additional information on the current status of the transducer, and, in the case of the first channel, the Acknowledge Bit that is used during a *Programming Cycle*. Figure 4.3 shows the format of a Status Word.

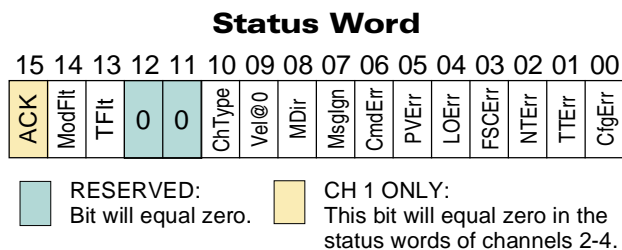

Figure 4.3 Status Word Format

Programming Error Bits

Programming error bits, (00-07), are not set until a Programming Cycle is initiated and remain set until the next Programming Cycle.

- CfgErr: Configuration Error, Bit 00.** Set if any reserved bits in the *Configuration Word* are set. Note that the RType bit, which is used to program the Resolver Type parameter, is only available when programming channel one. When programming channels two through four, this bit is reserved, and must equal zero.
- TTErr: Transducer Type Error, Bit 01.** This bit is always reset if the channel is configured for a single-turn transducer. This bit is set if the channel is configured for a multi-turn transducer and the Transducer Type word in the programming data does not equal 100, 180, 1,000, or 1,800 when the Resolver Type parameter is set to *AMCI*, or the Transducer Type word in the programming data does not equal 128 when the Resolver Type parameter is set to *Autotech*.
- NTErr: Number of Turns Error, Bit 02.** This bit is always reset if the channel is configured for a single-turn transducer. This bit is set if the channel is configured for a multi-turn transducer and the Number of Turns word in the programming data is not set to one of its proper values. Proper values for the Number of Turns parameter are based upon the value of the Transducer Type parameter and are listed in table 4.3, *Multi-Turn Parameter Ranges and Defaults* on page 34.
- FSCErr: Full Scale Count Error, Bit 03.** This bit is set if the Full Scale Count value is outside of its range. For single-turn channels, the range is 2 to 8,192. For multi-turn transducers, the range of the Full Scale Count is based upon the value of the Number of Turns parameter and is listed in table 4.3, *Multi-Turn Parameter Ranges and Defaults* on page 34.
- LOErr: Linear Offset Error, Bit 04.** This bit is set if the Linear Offset value is outside of its range. For single-turn channels, the range is 0 to (32,767 – Full Scale Count). For multi-turn transducers, the range of the Linear Offset is 0 to 999,999.
- PVErr: Preset Value Error, Bit 05.** This bit is set if the Preset Value is outside of its range of (Linear Offset) to (Linear Offset + (Full Scale Count – 1)). When the Linear Offset equals zero, the range simplifies down to 0 to (Full Scale Count – 1).
- CmdErr: Command Error, Bit 06.** Set if any reserved bits in the *Control Word* are set or if you attempt to program more than one channel at a time. It is also set if you attempt to use the *Apply Preset 2* or *Apply Preset 4* bits to preset a multi-turn channel.
- MsgIgn: Message Ignored, Bit 07.** If an error occurs when programming a parameter, the only way to clear the error is by setting the *Clear Errors* bit in the *Control Word*, or by re-programming the parameter to an acceptable value. This bit is set if neither of these actions occurred in the Programming Cycle immediately after the one that caused the error.

Status Word Format (continued)**Transducer & Unit Status Bits**

- MDir: Motion Direction, Bit 08.** This bit is reset when the position value is increasing and set when the position value is decreasing. This bit remains in its last state when there is no motion.
- Vel@0: Velocity at Zero, Bit 09.** This bit is reset when the transducer is in motion and set when there is no motion for 125 milliseconds.
- ChType: Channel Type, Bit 10.** This bit is reset if the channel is configured for a single-turn transducer and set if the channel is configured for a multi-turn transducer.
- TFIt: Transducer Fault, Bit 13.** This bit is set when a transducer fault is detected. If the *Transducer Fault Latch* is enabled, which it is by default, this bit remains set until it is cleared by a Programming Cycle that has the *Clear Errors* bit set in the *Control Word*.
- NxFIt: NX2A4C Fault, Bit 14.** This bit is set when the NX2A4C discovers a problem with its hardware. If this bit is set, initiate a Programming Cycle with the *Clear Errors* bit set in the *Control Word*. If the error remains, cycle power to the unit. If the error is still not cleared, *contact AMCI* for assistance. See the inside front cover for contact information. If the error does clear, then you will probably have to reprogram the unit because all parameters are usually set to their default values.
- ACK: Acknowledge Bit, Bit 15.** Set by the NX2A4C to acknowledge a *Programming Cycle* from the ControlNet master. *Programming Error Bits* in the Status words are valid while this bit is set. The *Transducer & Unit Status Bits* are always valid. The unit resets the Acknowledge bit after the ControlNet master resets the Transmit Bit.

CHAPTER 5

SAMPLE PROGRAM

Ladder Logic Format

The ladder logic on the following pages is written for the PLC-5, but can easily be converted to the ControlLogix platform because the instructions are the same. The way the data is addressed is the only thing that changes.

PLC-5 Data Format

- N9:0-22:** Integer data file words assigned to the NX2A4C input words. N9:0/15 is the Acknowledge Bit.
- N10:0-9:** Integer data file words assigned to the NX2A4C output words. N10:0/15 is the Transmit Bit.
- N14:0-29:** This thirty word file holds the three programming block that are written to the NX2A4C. N14:0-9 holds the first block which programs channel one. N14:10-19 programs channel two, and N14:20-29 programs channels three and four as a multi-turn channel.
- C5:0** Up Counter used to control which programming block is transmitted to the unit.

ControlLogix Data Format

- N9:** The N9 file references are replaced with the data tag you defined when configuring the RSLogix 5000 software. See *RSLogix 5000 Setup* starting on page 27. For example, if you named the NX2A4C “NexusNode”, then the input data would be at NexusNode:I.Data[0-22]. Because the first two words are reserved, the Acknowledge Bit would be at NexusNode:I.Data[2].15.
- N10:** Like the N9 references, the N10 references are replaced with the data tag you defined when configuring the RSLogix 5000 software. See *RSLogix 5000 Setup* starting on page 27. For example, if you named the NX2A4C “NexusNode”, then the output data would be at NexusNode:O.Data[0-9]. The Transmit Bit would be at NexusNode:O.Data[0].15.
- N14:** The N14 file references need to be replaced with arrays that you define to hold the data. You have a choice of three one-dimensional arrays or one two-dimensional array. For more information on defining arrays, refer to A-B documentation or help files.
- C5:0** The counter is replaced with the ControlLogix counter structure.

Data Values

	Address	Data (hex / decimal)	Comments
Programming Block 1	N14:0	4010h / 16,400d	Clear Errors and Program Single-turn Channel 1
	N14:1	0004h / 4d	AMCI resolvers, Tach Response = 24 mS, Transducer Fault Latch enabled, and Count Direction is <i>positive</i> .
	N14:2	0000h	Reserved
	N14:3	0168h / 360d	Full Scale Count of 360
	N14:4	0000h	Reserved
	N14:5	0000d	Linear Offset of zero
	N14:6	0000h	Reserved
	N14:7	0000d	Preset Value of zero
	N14:8	0000h	Reserved
	N14:9	0000h	Reserved
Programming Block 2	N14:10	4020h / 16,416d	Clear Errors and Program Single-turn Channel 2
	N14:11	0004h / 4d	Tach Response = 24 mS, Transducer Fault Latch enabled, and Count Direction is <i>positive</i> .
	N14:12	0000h	Reserved
	N14:13	0168h / 360d	Full Scale Count of 360
	N14:14	0000h	Reserved
	N14:15	0000d	Linear Offset of zero
	N14:16	0000h	Reserved
	N14:17	0000d	Preset Value of zero
	N14:18	0000h	Reserved
	N14:19	0000h	Reserved
Programming Block 3	N14:20	4200h / 16,896d	Clear Errors and Program Multi-turn Channel 2
	N14:21	0005h / 5d	Tach Response = 24 mS, Transducer Fault Latch enabled, and Count Direction is <i>negative</i> .
	N14:22	0024h / 36d	These two words set the Full Scale Count to 36,250
	N14:23	00FAh / 250d	
	N14:24	001dh / 29d	These two words set the Linear Offset to 29,000
	N14:25	0000d	
	N14:26	0041h / 65d	These two words set the Preset Value to 65,025
	N14:27	0019h / 25d	
	N14:28	0064h / 180d	Transducer Type set to 180 turn
	N14:29	0064h / 180d	Number of Turns set to 180

Table 5.1 Data Values

Ladder Logic

NX2A4C_EXAMPLE.RSP

LAD 2 - --- Total Rungs in File = 7

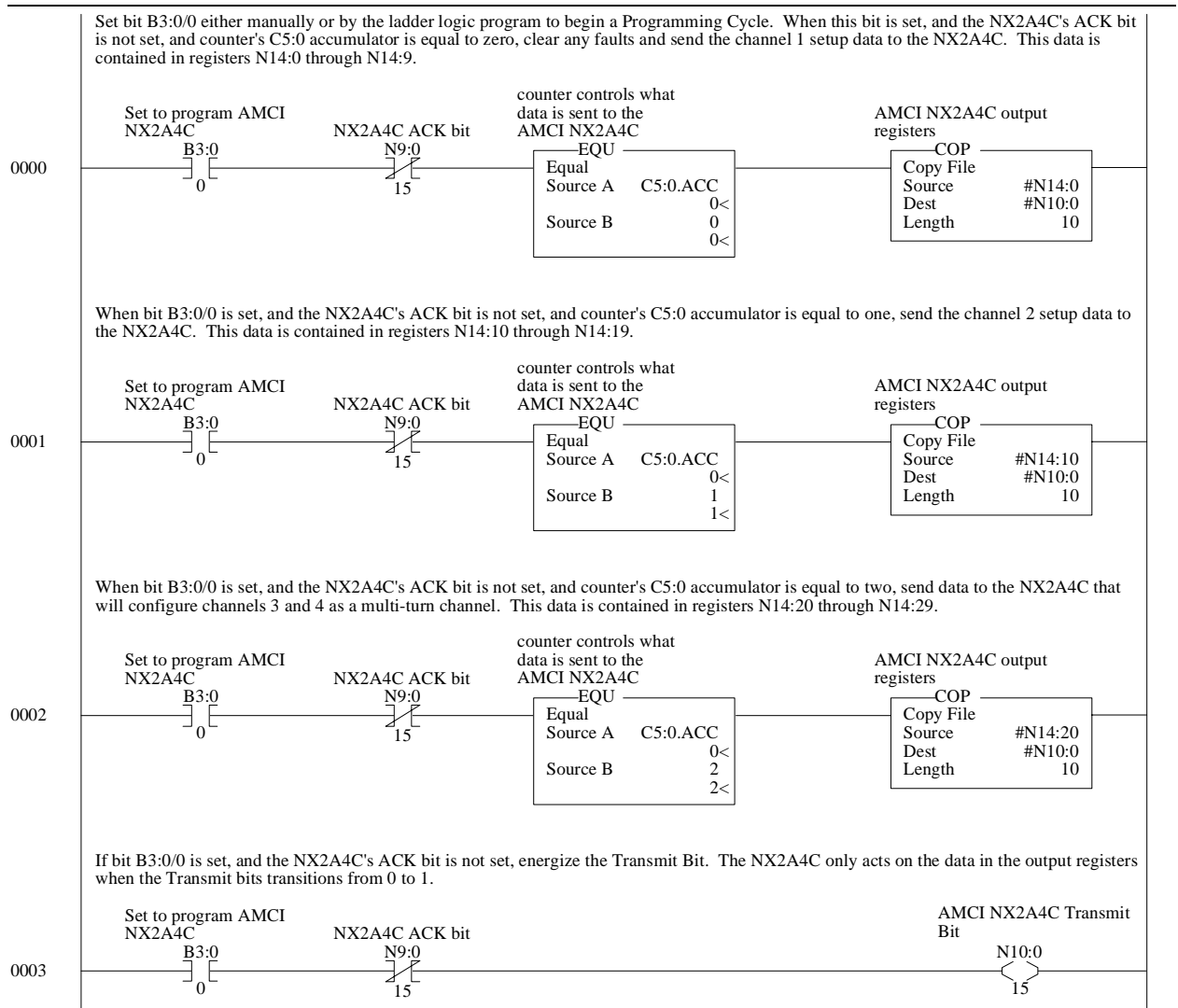

Ladder Logic (continued)

NX2A4C_EXAMPLE.RSP

LAD 2 - --- Total Rungs in File = 7

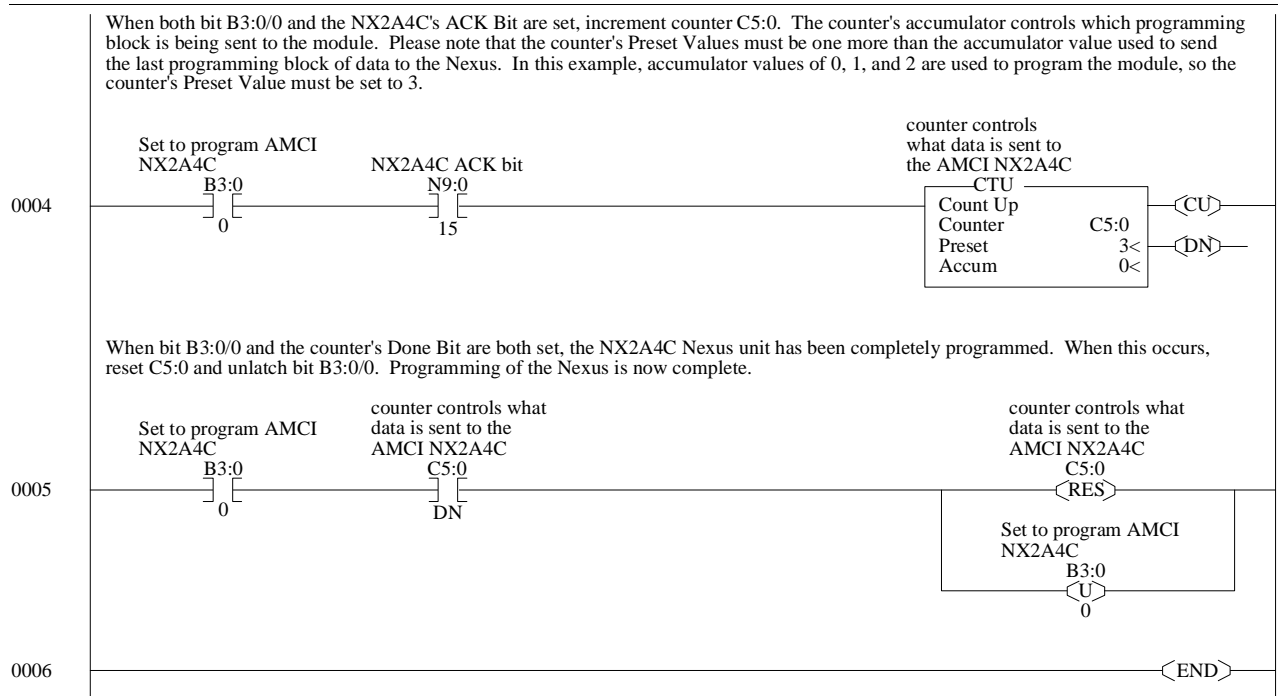

APPENDIX A

SHUT HEIGHT SETUP EXAMPLE

Background

This appendix covers a common setup problem encountered in the press industry. However, in its simplest form, the problem breaks down into setting the *Full Scale Count*, *Linear Offset*, and *Preset Value* parameters so that the transducer measures a linear distance in some form of engineering units such as inches or meters. Therefore, this appendix should be helpful in other applications, such as palletizing or overhead crane positioning.

The NX2A4C can only monitor the position of the load. Controlling the motor that positions the load is the responsibility of the PLC. AMCI's 2762-17 module for A-B 1771 I/O is a complete non-servo positioning module that includes two multi-turn transducer inputs and DC outputs for motor control. Additional information on the 2762-17, and its manual, can be found on our website: www.amci.com.

Definitions

Many large mechanical power presses have the ability to adjust the starting position of the ram or slide to accommodate different size dies. As shown in figure A.1, *Shut Height* refers to the distance between the slide and the base of the press when the press is at the bottom of its stroke.

Total Travel: The difference between the minimum and maximum shut heights. This is the maximum distance that can be travelled under normal operating conditions.

Transducer Travel: The distance that the transducer can encode. This distance must be greater than the Total Travel distance for the system to operate correctly.

Over Travel & Under Travel: As a safety feature, the parameters of the NX2A4C will be programmed so that the position value will be correct if the slide travels over or under its normal limits. The value of the Over Travel and Under Travel limits is equal to:

$$(\text{Transducer Travel} - \text{Total Travel}) / 2.$$

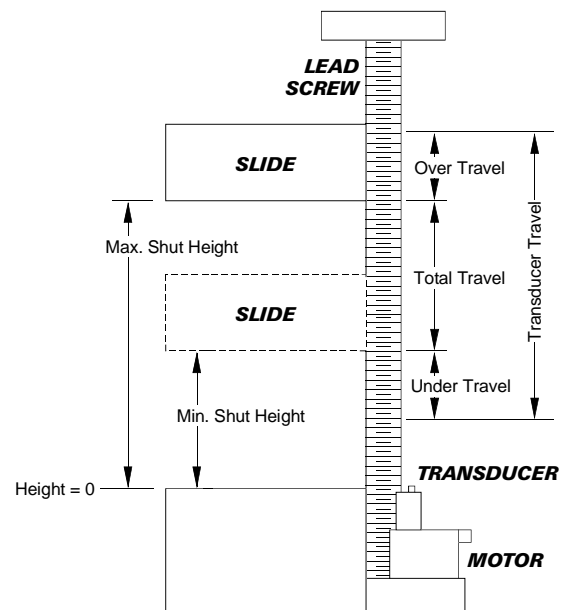

Figure A.1 Shut Height Example

Example Assumptions

- 1) The correct transducer has been chosen for the application. This means that the number of turns needed to traverse the Total Travel distance is less than the total number of turns of the transducer. This assumption also means that the number of counts needed per turn is less than or equal to the number of counts per turn available from the transducer. Both parts of this assumption are tested during the procedure.
- 2) The example uses an AMCI 180 turn transducer. If you are using a different transducer, refer to table 4.3, *Multi-Turn Parameter Ranges and Defaults* on page 34 for a listing of parameter ranges you'll need while programming the NX2A4C.
- 3) The minimum shut height is 29.000 inches and the maximum shut height is 64.000 inches.
- 4) Desired position resolution is 0.001 inches.
- 5) The slide moves 0.250 inches for each turn of the transducer shaft.

Calculating the Full Scale Count Parameter

If you know the minimum and maximum position values, (assumption 3), desired position resolution, (assumption 4), and the amount of travel per turn, (assumption 5), then you can easily determine the proper transducer to use and calculate the Full Scale Count parameter.

- 1) Total Travel equals the difference between the min. and max. position values:
 $\text{Total Travel} = 64.000 - 29.000 = 35.000 \text{ inches}$
- 2) Total Travel / Travel per Turn = Number of turns needed from the transducer.
 $35.000 / 0.250 = 140 \text{ turns. } 100 \text{ and } 128 \text{ turn transducers cannot be used in this application.}$
- 3) Counts per Turn = Travel per Turn / Desired Resolution
 $\text{Counts per Turn} = 0.250 / 0.001 = 250.$ The calculated counts per turn is below the maximums that can be programmed into the unit. Therefore, any transducer not eliminated by step 2 can be used.
- 4) Full Scale Count = Transducer's Number of Turns * Counts per Turn
 $\text{Full Scale Count} = 180 * 250 = 45,000$

Calculating the Linear Offset Parameter

Before calculating the Linear Offset parameter, you must calculate the amount of Under Travel available in your system. The amount of Over Travel is the same.

- 1) Under Travel equals one half of the difference between the Transducer's number of turns and the needed number of turns, multiplied by the number of counts per turn.
 $\text{Under Travel} = 1/2 * ((180 \text{ turns} - 140 \text{ turns}) * 250 \text{ counts/turn}) = 5,000 \text{ counts. } (5.000 \text{ inches})$
- 2) The Linear Offset equals the count at your minimum shut height minus the under travel count.
 $\text{Linear Offset} = 29,000 - 5,000 = 24,000.$

Determining the Preset Value

Instead of calculating the Preset Value, it's often easier to drive the slide to its low position and physically measure the shut height distance to determine the Preset Value. In our example, once driving the slide to its low position, the actual shut height distance is measured as 29.031 inches. The Preset Value would then be 29,031. Once the shut height distance is measured, it is important that you leave the slide at this position while programming the NX2A4C.

Programming the NX2A4C

This example programs channels three and four as multi-turn channel two. It does this because channel one must be configured as a single-turn channel in order to use the Stop Time monitor. Without further details, this application would commonly use channel one to monitor ram stroke position and the Stop Time monitor to measure press breaking time.

Table A.1 shows output data table values that must be sent to the NX2A4C to program it for this application.

This programming block must be sent to the NX2A4C while the slide is at the Preset Value position. If it is not, the unit will not be preset to the correct position.

		Value (hex / dec.)	Parameter
Programming Word	0	4204h / 16,900	Control Word. Program and preset multi-channel 2
	1	0000h / 0	Configuration Word. CW, Latch Enabled, 120 ms.
	2	002Dh / 45	Full Scale Count = 45,000
	3	0000h / 000	
	4	0018h / 24	
	5	0000h / 000	Linear Offset = 24,000
	6	001Dh / 29	Preset Value = 29,031
	7	001F / 031	
	8	0064h / 180	Transducer Type = 180
	9	0064h / 180	Number of Turns = 180

Table A.1 Programming Values



Verifying the Setup

Once the NX2A4C is programmed, the last step is to verify the setup. This is done by first driving the slide to its maximum shut height. It is important to drive it to its maximum so that you see the greatest accumulated error. Once at the maximum shut height, physically measure the distance and verify that the position value from the NX2A4C is correct at this height. If it is correct, your setup is complete.

If the position value from the NX2A4C is incorrect, then your value for the amount of linear travel per transducer turn was not accurate enough for these calculations and this ratio must be recalculated along with the Full Scale Count and Linear Offset parameters.

Before you can recalculate the linear travel per turn ratio, you must calculate the expected count change, and the actual count change. The Expected Δ Count is based on your physical measurements, the Actual Δ Count is based on the position readings from the NX2A4C.

If the physical reading at the maximum shut height was 63.980 inches, then:

$$\begin{aligned}\text{Expected } \Delta \text{ Count} &= (\text{Maximum Shut Height} - \text{Minimum Shut Height}) * \text{Resolution} \\ \text{Expected } \Delta \text{ Count} &= (63.980 \text{ inches} - 29.031 \text{ inches}) * 1,000 \text{ counts/inch} = 34,949 \text{ counts.}\end{aligned}$$

If the position value at the maximum shut height was 63,942, then:

$$\begin{aligned}\text{Actual } \Delta \text{ Count} &= \text{Count at Max. Shut Height} - \text{Count at Min. Shut Height} \\ \text{Actual } \Delta \text{ Count} &= 63,942 - 29,031 = 34,911.\end{aligned}$$

To recalculate the linear travel per turn ratio, use the following formula:

$$\text{Actual Ratio} = \text{Present Ratio} * (\text{Expected } \Delta \text{ Count} / \text{Actual } \Delta \text{ Count})$$

Therefore, the actual ratio becomes:

$$\text{Actual Ratio} = 0.250"/\text{turn} * (34,949 / 34,911) = 0.25027"/\text{turn}$$

You must use this ratio to re-calculate the Full Scale Count and Linear Offset values. If you don't move the slide before re-programming the NX2A4C, the Preset Value must be changed to the maximum shut height value that you physically measured.

After re-programming the unit, drive the slide to the minimum shut height and physically measure the gap. The position value from the unit should now be correct. If it isn't, the most likely culprit is that the slide is settling between the time that you measured the gap and the time you program this measurement into the NX2A4C as the Preset Value.



ADVANCED MICRO CONTROLS INC.

20 GEAR DRIVE, TERRYVILLE, CT 06786 T: (860) 585-1254 F: (860) 584-1973

www.amci.com

LEADERS IN ADVANCED CONTROL PRODUCTS