Module Overview

The 7252 module is a two-channel LDT interface module that resides in a Rockwell Automation ControlLogix rack.

This module is capable of connecting up to two independent LDT sensors with max 32-bit resolution for position. This module also has two latching inputs, one for each channel, which can be used to capture the sensor's data.

The 7252 module communicates with the PLC using input and output registers. The Data value, Velocity, Latched Value, and Status information are reported to the Input Registers. All module setup parameters, including Preset Value, Count Direction and Velocity Response Time are programmed through Message Instructions.

The Output registers assigned to the module can be used to Apply the Preset or to send the PLC's *Central System Clock-Time* to the 7252 module. This optional and additional feature causes the module to use this system time and the sensors velocity data to calculate an Interpolated or "Look Ahead" Data value.

The 7252 module stores its parameters in a non-volatile flash memory when power is removed so it is not necessary to program the module at every power up. However, this flash memory is good for a minimum of 10,000 write cycles, so the module must not be programmed during every machine cycle.

The two latching inputs are sinking and will activate when they see a voltage level between 8 and 24Vdc. These inputs can be programmed to capture the scaled sensor data on the rising, falling, or both transitions of the input.

Through the use of different rack Assembly Instances, the 7252 can be configured to operate with one or two of the available channels. Disabling the unused channel is recommended for improving the throughput time.

General Information

Important User Information

The products and application data described in this manual are useful in a wide variety of different applications. Therefore, the user and others responsible for applying these products described herein are responsible for determining the acceptability for each application. While efforts have been made to provide accurate information within this manual, AMCI assumes no responsibility for the application or the completeness of the information contained herein. Throughout this manual the following two notices are used to highlight important points.

WARNINGS tell you when people may be hurt or equipment may be damaged if the procedure is not followed properly.

CAUTIONS tell you when equipment may be damaged if the procedure is not followed properly. No patent liability is assumed by AMCI, with respect to use of information, circuits, equipment, or software described in this manual. The information contained within this manual is subject to change without notice. UNDER NO CIRCUMSTANCES WILL ADVANCED MICRO CONTROLS, INC. BE RESPONSIBLE OR LIABLE FOR ANY DAMAGES OR LOSSES, INCLUDING INDIRECT OR CONSEQUENTIAL DAMAGES OR LOSSES, ARISING FROM THE USE OF ANY INFORMATION CONTAINED WITHIN THIS MANUAL, OR THE USE OF ANY PRODUCTS OR SERVICES REFERENCED HEREIN.

Standard Warranty

ADVANCED MICRO CONTROLS, INC. warrants that all equipment manufactured by it will be free from defects, under normal use, in materials and workmanship for a period of [18] months. Within this warranty period, AMCI shall, at its option, repair or replace, free of charge, any equipment covered by this warranty which is returned, shipping charges prepaid, within one year from date of invoice, and which upon examination proves to be defective in material or workmanship and not caused by accident, misuse, neglect, alteration, improper installation or improper testing. The provisions of the "STANDARD WARRANTY" are the sole obligations of AMCI and excludes all other warranties expressed or implied. In no event shall AMCI be liable for incidental or consequential damages or for delay in performance of this warranty.

Returns Policy

All equipment being returned to AMCI for repair or replacement, regardless of warranty status, must have a Return Merchandise Authorization number issued by AMCI. Call (860) 585-1254 with the model and serial numbers along with a description of the problem. A "RMA" number will be issued. Equipment must be shipped to AMCI with transportation charges prepaid. Title and risk of loss or damage remains with the customer until shipment is received by AMCI.

24 Hour Technical Support Number

Technical Support, in the form of documents, FAQs, and sample programs, is available from our website, www.amci.com. 24 Hour technical support is also available on this product. For technical support, call (860) 585-1254. Your call will be answered at the factory during regular business hours, Monday through Friday, 8AM - 5PM EST. During non-business hours, an automated system will ask you to leave a detailed message and the telephone number that you can be reached at. The system will page an engineer on call. Please have your product model number and a description of the problem ready before you call.

Table of Contents

Installing the 7252 Module	Chapter 1	4
Hardware Overview	Chapter 2	5
	Module Specifications	5
	Front Panel & LED Function	6
	Connector Pinout	7
	Wiring Notes	8
	LDT Modes and Signals	9
Programmable Parameters	Chapter 3	11
	Transducer Fault Latch	11
	Count Direction	11
	Velocity Update Time	11
	Measurement Unit	11
	LDT Mode	12
	LDT Gradient	12
	Full Scale Length	12
	Full Scale Counts	12
	Preset Value	12
	Apply Preset	12
	Latched Input	13
	Limit Switch Position	13
	Interpolated Data Value	13
Message Instructions	Chapter 4	14
	Configuration Tab	14
	Writing Data Setup	15
	Reading Data Setup	15
	Communication Tab	16
	Extended Error Codes	16
Setup Data	Chapter 5	17
Reading Status Data	Chapter 6	18
Input & Output Data	Chapter 7	19
	Input Registers	19
	Status Bits	20
	Input Register Description	21
	Output Registers	22
	Command Bits	22
	Apply Preset Programming Cycle	22
	Interpolation Command Programming Cycle	23
Specification Revision History	Chapter 8	24

Chapter 1: INSTALLING THE 7252 MODULE

Configuring the ControlLogix System

1. Open RSLogix 5000 and the project in which you want to install the AMCI 7252 module.
2. Right click on I/O Configuration in the Project Tree.
3. Select New Module.
4. Select the following module type and description from the list that appears.

Type = 1756-MODULE

Description = Generic 1756 Module

5. Click on OK.
6. Enter the following module properties.

Name: *Your Choice* (must begin with a letter)

Description: *Your Choice*

Comm Format: *Data-DINT* (must be Data-DINT)

Slot: *location of 7252 module*

7. Enter the Connection Parameters from the following table. Please note that the 7252 module can be configured in two ways, depending on how many channels are being used. Disabling the unused channel is recommended because the module will stop all activities associated with the unused channel, which will improve the throughput time.

Owner Controller			Listen Only	
Parameter	Assembly Instance	Size in 32 bit words	Assembly Instance	Size in 32 bit words
1 Channel				
INPUT	101	5	101	5
OUTPUT	111	2	115	1
CONFIGURATION	1	0	5	0
2 Channels				
INPUT	102	10	102	10
OUTPUT	112	4	115	1
CONFIGURATION	2	0	5	0

The Owner Controller setup will be used in most instances. The Listen Only setup should only be used by the listening processor(s) in systems with more than one PLC. Please note that the RPI time of the Listen Only processor must be greater than or equal to the RPI of the Owner Controller, and the number of channels on the Listen Only processor must match the number of channels on the Owner Controller.

8. Click on Next >
9. Set the RPI (Rate Packet Interval) Time to the desired value. For the 7252 module, the RPI parameter has a range of 0.5 to 28ms, with a recommended RPI time of 5ms.
10. Click on Finish >>

The module should now appear in the project tree. The Input data will be referenced as Local:X.I.Data[Y] and the output data will be referenced as Local:X.O.Data[Y] where “X” is the slot number and “Y” is the word number.

Chapter 2: HARDWARE OVERVIEW

Module Specifications

Current Draw: 400ma @ 5Vdc from PLC backplane

Throughput Time: 0.2ms to 1.2ms depending on channels used.

RPI Value: 0.5 to 28ms, with a recommended RPI time of 5ms.

External Power: The 7252 module requires the use of an external +24Vdc power supply that is used power the input isolation circuitry and can also be used to power sensors that operate on 24Vdc

Voltage Range = +24V dc ($\pm 20\%$)

Current Draw = 150mA. Add this amount to your LDT encoder's current draw when sizing your external 24Vdc power supply.

5Vdc supply The 7252 module also uses the external power supply to generate a 5Vdc user power supply that can be used to power encoders and or sensors that run on 5Vdc. This 5Vdc supply can supply a maximum of 500mA ($\pm 5\%$) of current.

Latching Inputs The Latching Input terminals accept an up to 24VDC signal across pins 17-15, 18-16, The latching function is performed as programmed when power is applied/removed, OFF to ON and/or ON to OFF, to/from the input.

Voltage Range: 0 to 30Vdc

On State: 8 to 30Vdc

Off State: 0 to 2Vdc

Current Draw: 10mA @ 24Vdc

The latching inputs must be on for between 0.2ms and 1.2ms, depending on the number of channels being used.

Environmental Conditions Operating Temperature: 0 to 60° C
Relative Humidity: 5 to 95% (non-condensing)
Storage Temperature: -40 to 85° C

EDS File An EDS file for the 7252 module can be downloaded from the Tech Library section of AMCI's website, www.amci.com.

FLASH Memory

The 7252 module's parameter values are stored in a non-volatile Flash memory. This memory type can store parameter values in the absence of power for over twenty years, but you can only write to it a limited number of times before it will be damaged. The Flash Memory used in the 7252 module is guaranteed for a minimum of 10,000 write cycles.

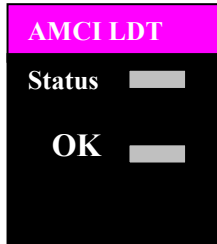
Front Panel:**Status LED**Solid Red

Data Flash Memory Fault

Blinking Red/Green

Module Hardware Comm. Failure

Blinking Red

Non Clearable Transducer Fault

Blinking Green

Clearable Transducer Fault

Solid Green

No Errors

OK LEDSolid Green:

Module Owned, two-way communication

Blinking Green:

PLC in Program Mode or rack configuration not correct

Blinking Red:

Communication between module and PLC interrupted, as when a new program is downloaded to the PLC.

The following is a list of possible causes of Transducer Faults

- Broken Transducer cable
- Improperly wired cable
- Non-compatible transducer
- LDT Mode setup parameter does not match the sensor type
- Magnet is not on the sensor
- Magnet is on the sensor but outside of the usable range
- External Power supply not attached to both the 7252 module and the sensor

By default, transducer fault errors will be removed as soon as the problem has been corrected. However, if the 7252 module has been programmed for Transducer Fault Latch, the status LED will remain blinking green until the Clear Latched Transducer Fault command has been sent from the Output Registers. Cycling power to the module will also clear a Latched Transducer Fault.

Connector Pin Out:

The input connector consists of a Removable Terminal Block with the Rockwell Automation Part Numbers 1756-TBCH (36 position cage clamp) or 1756-TBS6H (36 position spring clamp). The terminal block is not supplied with the 7252 module.

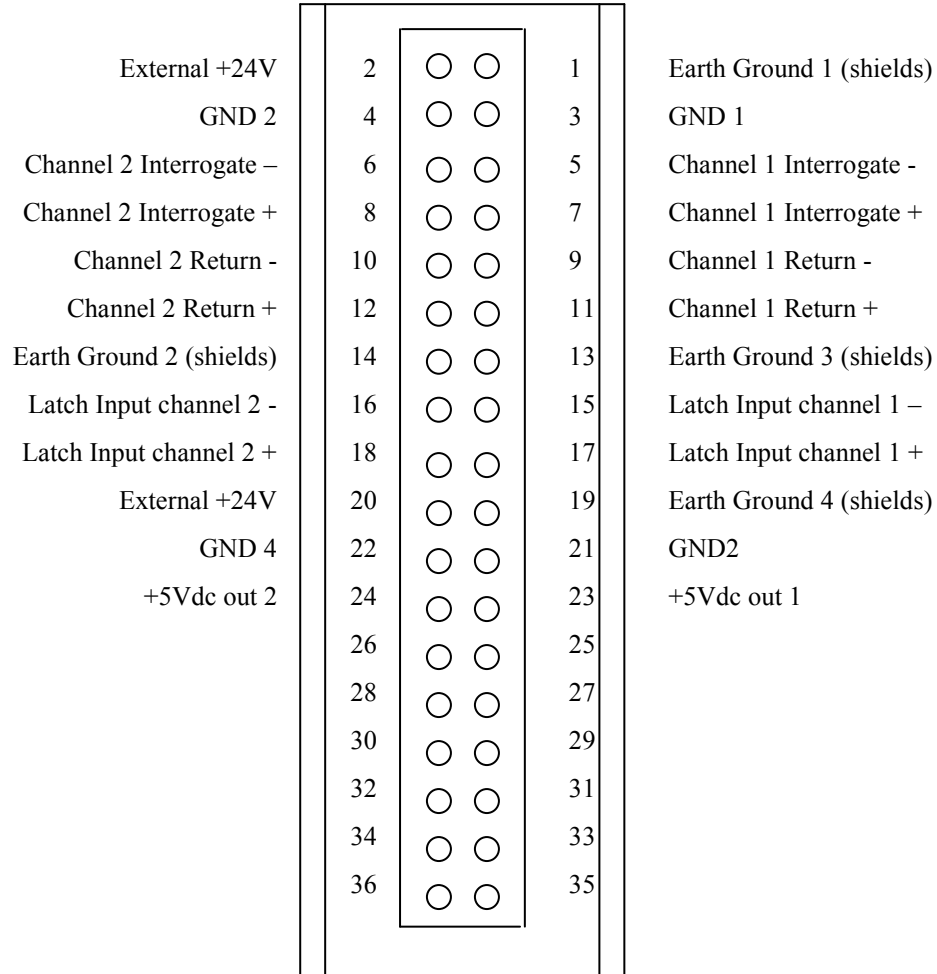

Wiring Notes

- Use the information provided by the transducer's manufacture to determine the type and maximum length of cable that should be used to connect the sensor to the 7252 module.
- When plugged into the 7252 module, pin 1 is located in the upper right hand corner.
- External +24Vdc (pins 2 and 20) are internally connected together.
- GND1/2/3/4 (pins 3, 4, 21 and 22) are internally connected together and must be connected to the external +24Vdc supply's common.
- The 7252 module uses the external +24Vdc supply to power the isolation circuitry and to generate +5Vdc user power (pins 23 and 24). These two pins, which are internally connected together, can be used to power sensors requiring less than 500 mA of current.

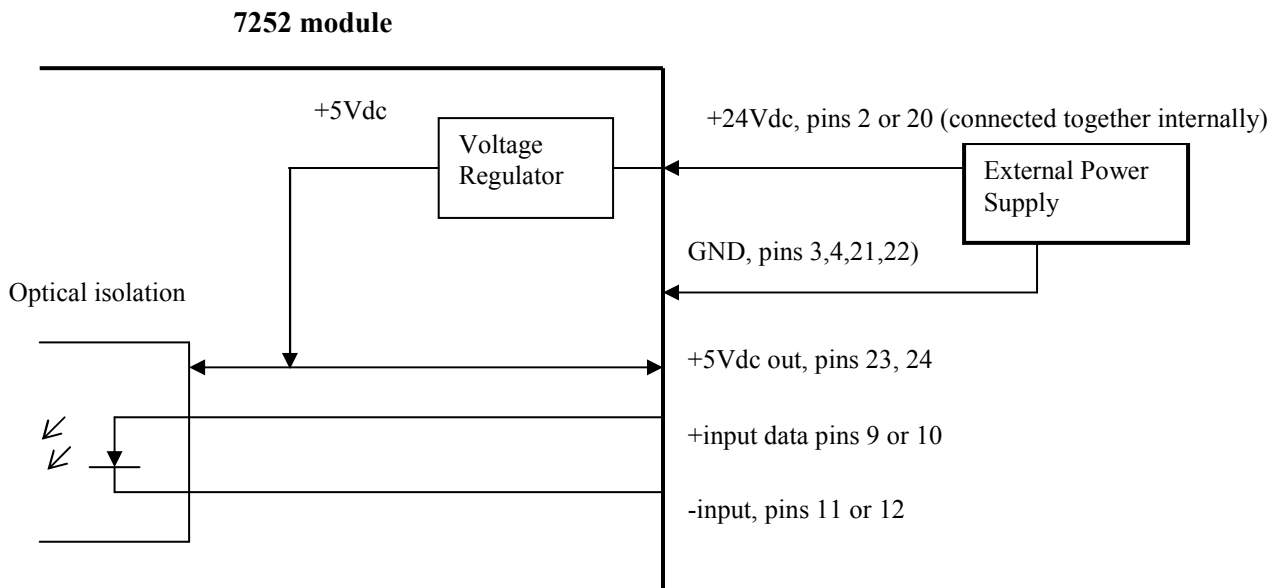

- Earth Grounds 1 through 4 (pins 1, 13, 14 and 19) are internally connected together and are connected to the ControlLogix rack structure. The cable shields of the sensor's cable should be connected to these terminals.
- Transducer signals are generally low voltage, low power signals. If you are using A-B guidelines for cabling installation, treat the transducer cable as a Category 2 cable. It can be installed in conduit along with other low power cabling such as communication cables and low power ac/dc I/O lines. It cannot be installed in conduit with ac power lines or high power ac/dc I/O lines.
- Like all signal and communication cable, the transducer cable should be shielded. These shields must be grounded only at one end of the cable. Because the rack cabinet is typically better grounded than the machine, AMCI recommends that the cable shields be terminated at the 7252 module. However, if your cable shield is attached to the sensor's housing, and the sensor is grounded through its mounting, you must not connect the cable shields to the 7252 module because this will create a ground loop.
- If a junction must be made in the signal cable, treat the shield as a signal-carrying conductor. Do not connect the shield to ground at any junction box or the encoder/sensor.
- If the signal cable must cross power feed lines, it should do so at right angles.
- Route the cable at least five feet from high voltage enclosures, or sources of RF radiation.

LDT Modes and Signals

The 7252 module supports four type of LDT transducer signaling:

1. Start/Stop Mode

The Start/Stop signal interface of the 7252 module is differential RS-422 output. The module initiates a start pulse a minimum of 1.0 microsecond in duration. Within 50 nanoseconds after the leading edge of the start pulse, the LDT will generate an output start pulse of 2 microseconds in duration. An output stop pulse of 2 microseconds in duration will follow from the LDT. The time it takes from the leading edge of the LDT output start pulse to the leading edge of the LDT output stop pulse is proportional to the distance from the null zone to the LDT magnet. The order of these pulses is illustrated in the following figure.

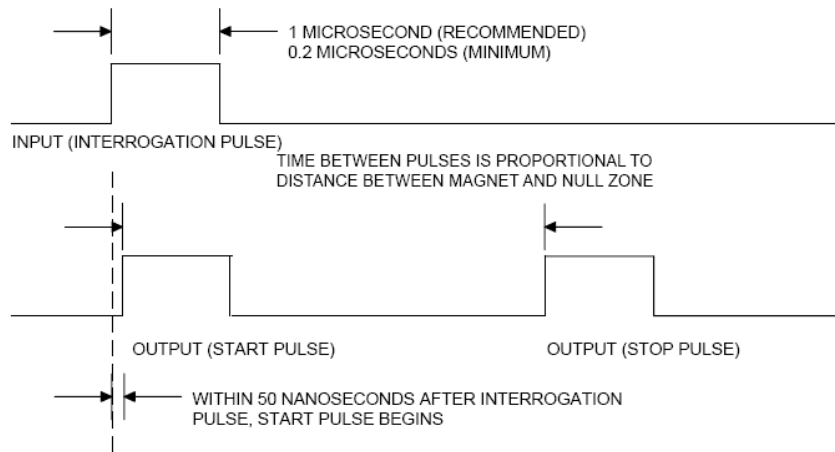

2. Control Pulse Mode

The Control Pulse signal interface of the 7252 module is a differential RS-422 output. The 7252 module initiates a start pulse a minimum of 1.0 microsecond in duration. After the start pulse is received, the LDT will generate a stop pulse of 2 microseconds in duration. The time between the leading edge of the start pulse to the leading edge of the stop pulse is proportional to the distance from the null zone to the LDT magnet. The order of these pulses is illustrated in the following figure.

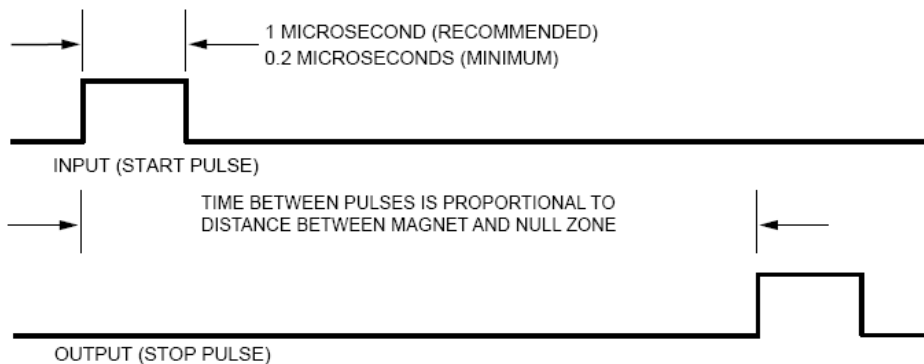

3. PWM Mode 1 (Variable Pulse with External Interrogation) – 7252 Default Mode

In PWM Mode 3, the signal interface is a pulse-width modulated RS-422 signal. In this mode the 7252 module is configured for external interrogation and generates a start pulse to begin measurement. This start pulse will be a minimum of 1.0 microsecond in duration. Within 50 nanoseconds after the leading edge of the start pulse has been received by the transducer, the LDT shall generate an output pulse with variable width. The duration of this output pulse is proportional to the distance from the null zone to the LDT magnet. The order of these pulses is illustrated in the following figure.

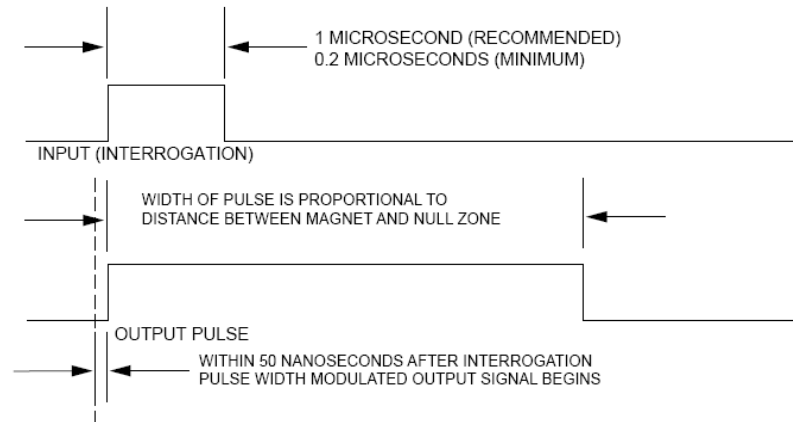

4. PWM Mode 2 (Variable Pulse with Internal Interrogation)

This mode is similar to PWM Mode 1, except that no interrogation from the 7252 module is needed. Instead, the LDT, when powered, will continually output pulse width modulated signals. The duration of this output pulse is proportional to the distance from the null zone to the magnet. The order of these pulses is illustrated in the following figure.

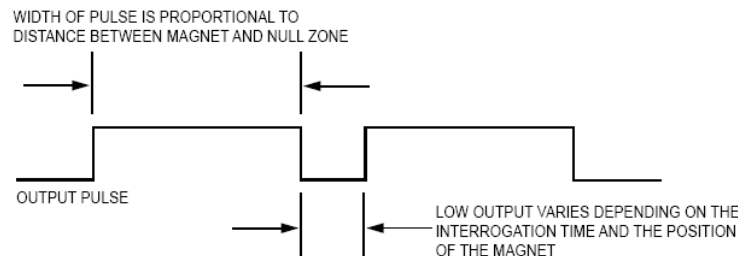

Recirculation

The recirculation method is used to improve the resolution of systems using digital LDT when the “on” time of a pulse width output is multiplied by a specific factor. This multiplication provides more counting time for the counter in the module’s electronics, thus improving the resolution.

The 7252 module does not use recirculations because it utilizes high-speed counters with enough resolution to ensure accurate measurements.

LDT sensors connected to the 7252 must be set for Number of Recirculations = 1, if this is a settable parameter.

Chapter 3: Programmable Parameters

The 7252 is configured by programming its Programmable Parameters. These parameters are broken down into three groups, Module Setup, LDT Setup, and Data Setup parameters.

The 7252 uses two methods for the programming and monitoring of data. Input and Output registers are used to program and monitor data that occurs on a regular schedule, such as reading the data value and status information or setting the system time. Message instructions are used for operations that occur less frequently, such as programming the module set up parameters or reading back the set up data for trouble shooting purposes.

Transducer Fault Latch - Transducer faults can be caused by improper wiring, electrical noise, or a damaged transducer. When the unit detects a fault condition, it reports this fault over the backplane. Normally, a transducer fault is not latched by the 7252 module and the Transducer Fault conditions will be cleared as soon as the 7252 module detects valid LDT signals. If you have a situation where electrical noise is causing spurious transducer faults that you can safely ignore, leave this parameter in its default condition. However, if you want to reliably capture these transient faults, then you must enable the Transducer Fault Latch parameter. In this case, you must send a Clear Error command to the 7252 module to clear the fault.

The default Transducer Fault Latch value is set to *Self Clearing*.

Count Direction: This parameter gives you the ability to reverse the direction of motion needed to increase the position count. For simplicity's sake, the two values for this parameter are called *Positive Direction* and *Negative Direction*. When this parameter is set to its default of *Positive*, the Data Value is not changed. When this parameter is set to *Negative*, the Data Value is multiplied by -1 before it is reported. For linear transducers, this has the effect of reversing the direction of motion needed to increase the count. When using LDT's and the Count Direction is set to *Positive*, the Data Value usually increases as the magnet moves away from the head of the LDT. When the Count Direction is set to *Negative*, the Data Value increases as the magnet moves towards the head of the LDT. You will need probably need to Apply the Preset to the Data Value after you program the Count Direction parameter.

Velocity Update Time: The Velocity Update Time parameter sets the amount of time between Rate of Change information updates to the PLC. Its can be set to either 60 milliseconds or 160 milliseconds, with 160 milliseconds being the default. Decrease the time between updates for faster response to changes in this value. Increase the time between updates for better averaging of this value. The Velocity update time does not affect the rate at which the position data is updated.

The Velocity data is measured in Counts/Second. For example, if you have programmed the 7252 module for 0.001 inch resolution, and if the magnet is moving at a rate of two inches per second, then the 7252 module will report a velocity value of 2000 counts / second.

Measurement Unit - Specifies the measurement unit for the Full Scale Length parameter and affects the values that can be entered for Full Scale Count. This bit will indicate whether the unit of measurement is in inches or mm (millimeters).

- When this bit is set to '1', the position and velocity data is reported back in mm with a maximum resolution of 0.1mm
- When this bit is set to '0', the unit of measurement will be reported back in inches with a maximum resolution of 0.001 in
- The default Measurement Unit parameter is inches

LDT Mode – Three Configuration Word bits are used to select the desired LDT mode, which can be one of the four modes described in Chapter 2:

- Start/Stop Mode (default)
- Control Pulse Mode
- PWM Mode 1
- PWM Mode 2

LDT Gradient (Wire Speed) - This is a calibration parameter supplied by the LDT manufacturer and defines how fast the pulse travels down the waveguide of the sensor. The data reported by the 7252 module will be repeatable, but not accurate, if an incorrect Gradient value is used.

LDT manufacturers specify the gradient in $\mu\text{Sec}/\text{inch}$, $\mu\text{sec}/\text{mm}$, or meters/second.

The gradient value used by the 7252 module has a range of 80000 to 99999, a default value of 90000 (for 9.0000 $\mu\text{sec}/\text{inch}$) and is always programmed in $\mu\text{sec}/\text{inch}$. Use the following formulas to convert from $\mu\text{sec}/\text{mm}$ or meters/second to $\mu\text{sec}/\text{inch}$.

Gradient in $\mu\text{sec}/\text{inch}$ = (Gradient in $\mu\text{sec}/\text{mm}$ * 25.4 mm/inch)

Gradient in $\mu\text{sec}/\text{inch}$ = 1 / (Gradient in meters/sec * 0.0003937)

Full Scale Length - Most commonly set to the expected length of travel, the Full Scale Length can actually be any value that simplifies the Full Scale Count value. Based on the Measurement Unit setting, the range of values is 2 to 800 inches or 2 to 20320 millimeters. Default value of 16 inches.

Full Scale Count - Sets the number of counts over the specified Full Scale Length. The range of values is 2 to (Full Scale Length * 1000) if Measurement Unit is inches or 2 to (Full Scale Length * 10) if Measurement Unit is millimeters. Default value of 16000. (Resolution equals 0.001 inches)

Preset Value: The zero position of the LDT encoder's Data Value may not match the zero position of the application machine. The Preset Value parameter gives you the ability to offset the Data Value from the actual LDT data to a value that will be more useful for your application.

Programming the Preset Value parameter does not change the Data Value. It is stored in the 7252 module's memory until the module sees a zero to one transition of the Apply Preset bit in the output registers.

Apply Preset: Offsetting the Data Value to the Preset Value is a two step operation. First, a Message Instruction must be used to send the Preset Value with the other setup parameters to the 7252 module. Second, setting the Apply Preset bit in the output registers will change the Data Value to the Preset Value.

Setting the Apply Preset bit causes the module to generate an internal offset value that is applied to the Data Value before it is reported to the PLC. This internal offset is saved in the 7252 module's Flash memory, so it is not necessary to home the module at every power up. Please note that using a Message Instruction to program a channel's setup data will clear the internal offset generated by an Apply Preset operation.



The 7252 module's Flash memory is guaranteed for 10,000 write cycles before writing to it will cause it to fault. Therefore continuously applying the Preset should be avoided. If your application requires you to continuously apply the Preset, consider calculating and applying the Preset in your PLC program.

Latched Input: The 7252 module has two Latch Inputs, one for each channel, that allow you to capture and display the current Data Value whenever the input transitions. This parameter, which is composed of two bits, allows you to capture the input on the 0 to 1 transition, the 1 to 0 transition, or on both transitions. The function of the Latched Input will be disabled if neither bit is set.

To be read by the 7252 module, the latching inputs must be on for between 0.2ms and 1.2ms, depending on the number of channels being used.

The 7252 module reports the status of the Latched input even if the function of the latched input has been disabled.

The Latched Value is not saved through power down. Therefore, the Latched Value displayed in the 7252 module's input registers at power up will be zero.

Limit Switch Position: This two word parameters defines ON and OFF setpoints. If the ON setpoint is less than the OFF setpoint, a bit in the Input Registers, which can be easily interrogated by a relay instruction, will be set when the Data Value is between these two setpoints. If the ON setpoint is greater than then OFF setpoint, then the bit will be set when the Data Value is outside of the these two setpoints. A separate Limit Switch bit based on the same ON/OFF setpoints also exists for the Interpolation Data Value.

Interpolated Data value: This additional and optional feature may be useful for customers using the ControlLogix PLC's virtual axis functionality. If used, the 7252 module will take the PLC's *Central System Clock-Time* and the sensor's velocity data to calculate an Interpolated or "Look Ahead" Data value. This has two possible functions. One, the Interpolated Data Value along with the time value can be sent to other ControlLogix modules, for example the AMCI 8213-VA, allowing them to schedule their responses with a high degree of precision. Two, the Interpolated Data Value allows the user to "Look Ahead" to what the Data Value will be at a defined time in the future. Here is the procedure for generating the Interpolation Data Value.

1. Make the PLC the System Time Master by opening the Controller Properties and clicking on the Date/Time tab. Click on the box next to the "Make this controller the Coordinated System Time Master" text so that a check mark appears in the box and accept the changes by clicking on OK. The Interpolated position value will be valid only if this step is performed.
2. Create a GSV instruction in your ladder logic, with the Class Name set to CST and the Attribute Name set to CurrentValue, to read the system time from the PLC. The destination address must made up of two DINT registers.
3. If desired, add a value to word 0 of the time value read above. This value is entered in 1 μ s increments, every 1000 equals 1ms, and equals the amount of time that you want to "look ahead."
4. Place the time value from step 3 into the output registers. The next time that the Interpolation Transmit bit transitions from either 0 to 1 or 1 to 0, the Central System Time will be sent to the 7252 module.
5. The latest Interpolation Data Value will be located in the input data the next time the module is updated at the normal RPI update.

Chapter 4: Message Instructions

The programming of the 7252 module's Setup data requires the use of Message Instructions. The format of this instruction is shown below.



1. A different message instruction is needed for each channel of the 7252 module.
2. The message instruction sends data to or reads data from the 7252 module only when the rung transitions from false to true.
3. The Message Control tag, message_ch1 in this example, used for Message Instruction Control must have the MESSAGE data type.
4. Clicking on the button in the Message Instruction opens the Message Configuration Window, shown below. Enter the appropriate data for the channel and operation being performed. When finished, click on the Apply button to accept the new data.

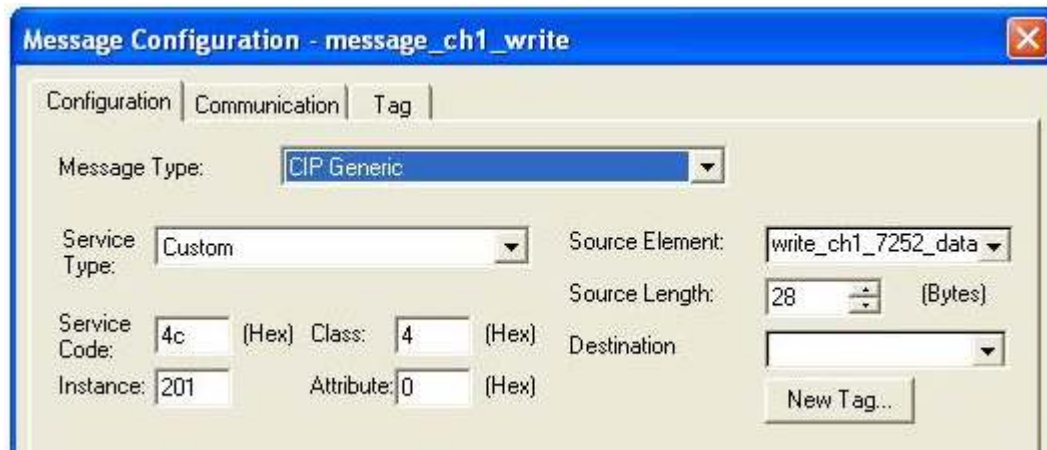

Message Type: CIP Generic

Service Type: Must be Custom

Service Code: 4C to write data to the 7252 module, 4B to read data from the 7252 module

Class: Must be equal to 4.

Instance: Determined by the type of data being transferred, see the table below.

Attribute: Must be set to zero.

Source Element: If the Message Instruction is being used to send data to the 7252 module, then the source parameter will be the first tag of the array that contains the data to be sent to the 7252 module.

If the Message Instruction is being used to read data from the 7252 module, than the source parameter must be left blank.

Source Length: If the Message Instruction is being used to send data to the 7252 module, then the Source Length parameter must be equal to 28 bytes.

If the Message Instruction is being used to read data from the 7252 module, then the Source Length Parameter must be set to zero.

Destination: If the Message Instruction is being used to send data to the 7252 module, then the Destination Parameter must be left blank.

If the Message Instruction is being used to read data from the 7252 module, then the Destination Parameter must be set to the first tag of the array where the data will be placed.

The Message Instruction is used with the following information to send Setup Data to the 7252 module.

LDT Channel 1	SERVICE CODE	4C	CLASS	4	Length in [Bytes] 28	Used with assembly instances 101, 102
	INSTANCE	201	ATTRIBUTE	0		
LDT Channel 2	SERVICE CODE	4C	CLASS	4	Length in [Bytes] 28	Used with assembly instance 102
	INSTANCE	202	ATTRIBUTE	0		

The Message Instruction is used with the following information to read Setup Data from the 7252 module.

LDT Channel 1	SERVICE CODE	4B	CLASS	4	Length in [Bytes] 0	Used with assembly instances 101, 102
	INSTANCE	201	ATTRIBUTE	0		
LDT Channel 2	SERVICE CODE	4B	CLASS	4	Length in [Bytes] 0	Used with assembly instance 102
	INSTANCE	202	ATTRIBUTE	0		

Message Configuration – (Communication Tab)

When the Configuration window shown above is completed, click on the Communication tab. The following window will open. Click on the Browse button and set the path parameter to the slot where the 7252 module is located. All of the remaining Communication parameters can remain at their default settings.

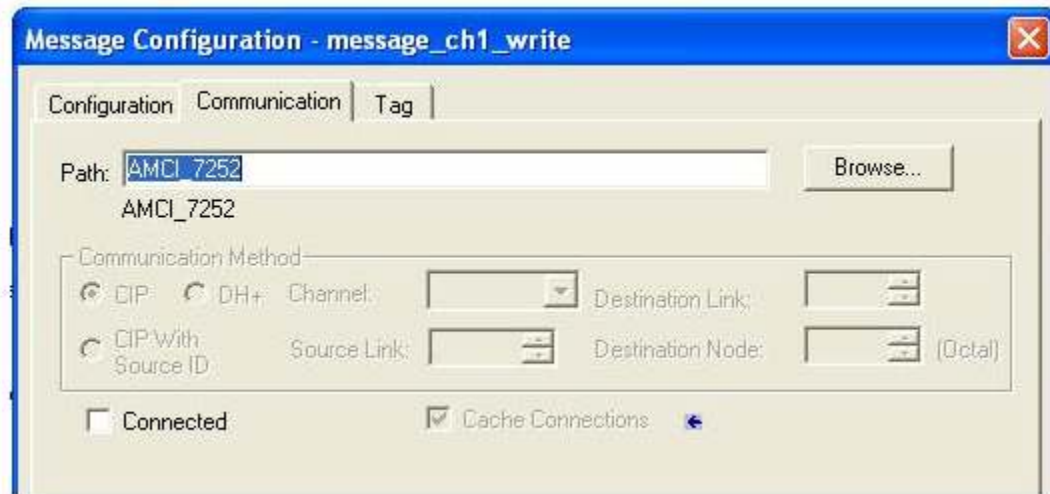

Extended Error Codes

The Message Instructions used to send data to the 7252 module have an error register that can be used to obtain diagnostic information from the module. This register's address is *user_tag.exerr*. The following table shows the values that will be displayed in this register if the data sent to the 7252 module is not valid.

Extended Error Codes	
1	Configuration Bits Word Format Error <ul style="list-style-type: none"> Reserved bits not equal to 0 Selecting one of the reserved LDT mode types
2	LDT Gradient Value is outside of its valid range of 80000 to 99999
3	Full Scale Length is outside of its valid range of <ul style="list-style-type: none"> 2 to 800 if the units are in inches 2 to 20320 if the units are in millimeters
4	Full Scale Count is outside of its valid range of <ul style="list-style-type: none"> 2 to (1000 * Full Scale Length) if the units are in inches 2 to (10 * Full Scale Length) if the units are in millimeters
10	Trying to program channel 2 when the rack configuration has defined the 7252 as a one channel module. (This will be displayed as 16#0000_000A)

- These error codes are only valid when register address *user_tag.err* is equal to 9.
- The Message Instructions Error bit and the Extended Error Code can only be cleared by sending valid data to the 7252 module.

Chapter 5: Setup Data

The message instructions described in chapter 4 above are used to send the setup data to the two channels of the 7252 module. This data consists of seven 32 bit words (28 bytes) shown in the following table. Each channel can be programmed with different setup data.

Setup Data for the LDT Module

Data Type	Word Number	Function	Range	Factory Default
32-bit	0	Configuration Bits	See description below	0
32-bit	1	LDT Gradient	80000 to 99999	90000 (9.0 μ s/inch)
32-bit	2	Full Scale Length	2 to 800 inches or 2 to 23300 mm	16 inches
32-bit	3	Full Scale Count	2 to (1000 * Length in inches) or 2 * (Length in mm * 10)	16000
32-bit	4	Preset Value	0 to 16# FFFF_FFFF -2,147,483,648 to +2,147,483,647	0
32-bit	5	Limit Switch ON-Position	0 to 16# FFFF_FFFF -2,147,483,648 to +2,147,483,647	0
32-bit	6	Limit Switch OFF-Position	0 to 16# FFFF_FFFF -2,147,483,648 to +2,147,483,647	0

All of the data must be present and valid when the message instruction is used to send the data to the 7252 module. If the data is not valid, all of the data will be ignored, the message instruction's error bit will be set, and the extended error code will indicate exactly how the data is invalid. See chapter 3 for definitions of the set up parameters.

Configuration Bits:

Bits 0 to 7: Reserved, must be 0;

Bit 8: Transducer Fault Latch (0=self clearing, 1 = Latched Fault)

Bit 9: Program Count Direction (0 = Positive, 1 = Negative)

Bit 10: Program Velocity Update (0 = 160ms, 1 = 60ms)

Bit 11: Latch position on rising edge of input

Bit 12: Latch position on falling edge of input

Bit 13: Measurement Units (0=inches, 1=mm)

Bit 14 to 16: LDT Mode

Bit 16	Bit 15	Bit 14	LDT Mode
0	0	0	Start/Stop Mode (default)
0	0	1	Control Pulse Mode
0	1	0	PWM Mode 1
0	1	1	PWM Mode 2
1	0	0	reserved
1	0	1	reserved
1	1	0	reserved
1	1	1	reserved

Bits 17.. 31: Reserved, must be 0;

Note 1: The Velocity Update Time does not affect the update of the Data Value.

Note 2: Programming a channel's setup data will clear the internal offset generated by an Apply Preset Operation.

Note 3: The 7252 module will accept and act on Setup Data sent from a Message Instruction that occurs in a Listen Only Processor.

Note 4: The gradient value is entered with an assumed decimal point. For example, a gradient of 9.1234 would be entered as 91234. Zeros must be entered in any unused places. For example, a gradient of 9.12 would be entered as 91200.

NOTE: Power Up

The 7252 will power up and start sampling the channels immediately. At this time, it will either use the Setup Data Words 0-6 (page 17) from the Flash memory, or if there is none present, it will use their default values (out-of-the-box state).

Chapter 6: Reading Status Data

The message instructions described in Chapter 4 above can be used to read the current setup data from each of channels of the 7252 module. This status data consists of eight 32 bit words. The destination address must be made up of a tag array that is at least eight DINT words long.

Please note that it is possible to read only valid data from the 7252 module. The module does not store any Setup Data that caused the Message Instruction's Error bit to be set.

Reading Data from the LDT Module

Data Type	Word Number	Function
32-bit	0	Configuration Bits
32-bit	1	LDT Gradient
32-bit	2	Full Scale Length
32-bit	3	Full Scale Count
32-bit	4	Preset Value
32-bit	5	Limit Switch ON-Position
32-bit	6	Limit Switch OFF-Position
32-bit	7	Internal Offset generated by an Apply Preset operation

Configuration Bits:

Bits 0 to 7: Reserved, will be 0;

Bit 8: Transducer Fault Latch (0=self clearing, 1 = Latched Fault)

Bit 9: Program Count Direction (0 = Positive, 1 = Negative)

Bit 10: Program Velocity Update (0 = 160ms, 1 = 60ms)

Bit 11: Latch position on rising edge of input

Bit 12: Latch position on falling edge of input

Bit 13: Measurement Units (0=mm, 1=inches)

Bit 14 to 16: LDT Mode

Bit 16	Bit 15	Bit 14	LDT Mode
0	0	0	Start/Stop Mode
0	0	1	Control Pulse Mode
0	1	0	PWM Mode 1
0	1	1	PWM Mode 2
1	0	0	reserved
1	0	1	reserved
1	1	0	reserved
1	1	1	reserved

Bits 17.. 31: Reserved, will be 0;

Chapter 7: Input & Output Data

Input Registers: (Data sent from the 7252 module to the PLC)

The input data consists of five (for 1 channel) or ten (for 2 channels) 32-bit words, and is read by the PLC at the RPI (Requested Packet Interval) Time that is asynchronous to the Ladder Logic Program. The Input data will be referenced as Local:X.I.Data[Y] where “X” is the slot number and “Y” is the word number.

To ensure that the same data is used throughout the entire PLC program, this data should be buffered to internal registers at one place in the program. However, in order to take advantage of the real time availability of the *Interpolation Data value*, the *Interpolation Acknowledge* bit, the *Limit Switch State Bit*, and the *Interpolation Limit Switch State Bit* should be used directly from their respective Input Registers.

The data contained in the input registers consists of Status Word, Data Value, Velocity and any associated Latched or Interpolated Data Values.

Input Data for the 1 Channel Configuration

Channel Number	32 Bit Word	Function	Units
1	0	Status Word1	See descripiton below
	1	Data Value 1	Counts
	2	Velocity 1	Counts / Second
	3	Latched Data Value 1	Counts
	4	Interpolated Data Value 1	Counts

Input Data for the 2 Channel Configuration

Channel Number	32 Bit Word	Function	Units
1	0	Status Word 1	See descripiton below
	1	Data Value 1	Counts
	2	Velocity 1	Counts / Second
	3	Latched Data Value 1	Counts
	4	Interpolated Data Value 1	Counts
2	5	Status Word 2	See descripiton below
	6	Data Value 2	Counts
	7	Velocity 2	Counts / second
	8	Latched Data Value 2	Counts
	9	Interpolated Data Value 2	Counts

Description of the Status Word:

Bit 0: APPLY PRESET ACKNOWLEDGE: This bit will be set when the corresponding Apply Preset Command bit is set in the output registers.

Bit 1: INTERPOLATION ACKNOWLEDGE: This bit will be set when the corresponding Interpolation Command bit is set in the output registers, after carrying out the INTERPOLATION operation.

Bit 2: VELOCITY AT ZERO: Set when there has been no motion for the last portion of the Velocity Update Time.

Bit 3: MOTION DIRECTION: Set when data value is decreasing. The bit remains in the last state when there is no motion.

Bit 4: LATCHING INPUT: Set when the latching input for respective channel is receiving power. This bit will be set to indicate that the input is active even if the function of the input has been disabled by the channel's programming.

Bit 5: LIMIT SWITCH STATE: Set when the data value is between the programmed Limit Switch *ON-* and *OFF-Setpoints*.

Bit 6: INTERPOLATION LIMIT SWITCH STATE: Set when the interpolated data value is between the programmed Limit Switch *ON-* and *OFF-Setpoints*. This bit will only be updated on the 0 to 1 or 1 to 0 transitions of the Interpolation Command Output bit.

Bit 7: TRANSDUCER FAULT: This bit will be set to indicate one of the following conditions.

- Broken Transducer cable
- Improperly wired cable
- Non-compatible transducer
- LDT Mode setup parameter does not match the sensor type
- Magnet is not on the sensor
- Magnet is on the sensor but outside of the usable range
- External Power supply not attached to both the 7252 module and the sensor

By default, transducer fault errors will be removed as soon as the problem has been corrected. However, if the 7275 module has been programmed for Transducer Fault Latch, this bit will remain set until the Clear Latched Transducer Faults command has been sent from the Output Registers. Cycling power to the module will also clear a Latched Transducer Fault.

Bits 8 to 13: Reserved for future use

Bit 14: OUTPUT FAULT: Set when one or more of the bits in the corresponding COMMAND WORD are set. This bit will be automatically reset when the incorrect bit(s) are reset.

Bit 15: BAD CRC Memory Error: Set when the flash area for the corresponding channel parameters shows corrupt data. It will still be possible to use the 7252, but the module will power up using its default parameters.

That is, you will have to use message instructions to program your setup data at every power up. If you do not want to use the module in this way, it must be returned to AMCI for repair.

Bits 16 to 31: Reserved for future use

Input Register Description

Data Value: This register contains the position data from the sensor after it has been scaled, and after the Count Direction, Measurement Unit, and Preset Value have been applied.
Range is from -2,147,483,648 to +2,147,483,647

Velocity: This is the rate of change of the data value in Counts / Second. For example, if you have programmed the 7252 module for 0.001 inch resolution, and if the magnet is moving at a rate of two inches per second, then the 7252 module will report a velocity value of 2000 counts / second.

Latched Data Value: This register shows what the Data Value was when the Latch Input transitioned, depending on the configuration, from 0 to 1 and or from 1 to 0. The Latched Data Value will be reset to zero at power up. Also, the current Data Value will be placed in this register if the input is configured for the 0 to 1 transition and the input is active at power up.
Range is from -2,147,483,648 to +2,147,483,647

Interpolated Data Value: This register shows the Data Value based on the Central System Time and the sensor's velocity data. It is not necessary to use this feature if you are only interested in reading the Data Value and Velocity directly from the sensor.
Range is from -2,147,483,648 to +2,147,483,647

Output Registers: (Data sent from the PLC to the 7252 module)

The output registers are used to execute commands that typically occur during machine operation, while module setup functions are accomplished with the use of Message Instructions. See chapter 3 and 4 for configuring the 7252 module.

1 Channel configuration

Channel Number	32 Bit Word	Function
1	0	Command Bits
	1	Interpolation CST Value

2 Channels configuration

Channel Number	32 Bit Word	Function
1	0	Command Bits
	1	Interpolation CST Value
2	2	Command Bits
	3	Interpolation CST Value

Command Bits for channels 1 & 2:

Bit 0: APPLY PRESET COMMAND: The 0 to 1 transition of this bit changes the respective EnDat channel's Data Value to the Preset Value that was programmed with the channels Setup Message Instruction. The Default Preset Value is zero.

Bit 1: INTERPOLATION COMMAND: Both transitions of this bit, (0 to 1) and (1 to 0), causes the respective EnDat channel to read the Current System Time from the output register and calculate the Interpolated Data Value. This Interpolated Data Value will be read by the PLC during the next RPI update of the module.

Bit 2: CLEAR LATCHED TRANSDUCER FAULTS: A 0 to 1 transition of this bit will clear a Latched Transducer Fault Error message.

Bits 3 to 31: Reserved for future use

Apply Preset Programming Cycle

1. The ladder logic program sets the APPLY PRESET COMMAND bit when you want to change the channel's current Data Value to the previously programmed Preset Value.
2. The 7252 module will set the APPLY PRESET ACKNOWLEDGE bit in the input registers to indicate that it has received the command.
3. When the ladder logic program sees that the APPLY PRESET ACKNOWLEDGE bit is set, it will reset the APPLY PRESET COMMAND bit. The programming cycle is now complete.



WARNING

The 7252 module's Flash memory is guaranteed for 10,000 write cycles before writing to it will cause it to fault. Therefore continuously applying the Preset should be avoided. If your application requires you to continuously apply the Preset, consider calculating and applying the Preset in your PLC program.



WARNING

Programming the 7252's setup parameters will reset the internal offset generated by an Apply Preset operation. If you are programming the unit's setup parameter at every power up, this may be the reason that your data value to not be absolute through power down.

Interpolation Command Programming Cycle

1. The ladder logic program reads the desired *Central System Time* value from the PLC using a GSV instruction. The Destination tag must consist of at least two DINT registers.
2. If desired, add the amount of time, in microseconds, that you want to “look ahead” to the lower word of Central System Time.
3. Write the desired *Central System Time* value into the *Interpolation CST Value* Output Register.
4. Based on the state of the Interpolation Acknowledge bit, toggle the Interpolation Command bit either on or off.
5. Based on the measured *Velocity* for the corresponding sensor channel, the 7252 module calculates the *Interpolated Data Value* and places it in the respective *Input Register*. The 7252 module then adjusts the *Interpolation Acknowledge Bit* accordingly.

If desired, the user can send the Interpolated Position, along with the system time, to another ControlLogix module each time the Interpolation Acknowledged bit changes state.

The following is an example of the ladder logic that can be used to generate the Interpolation Data Value.

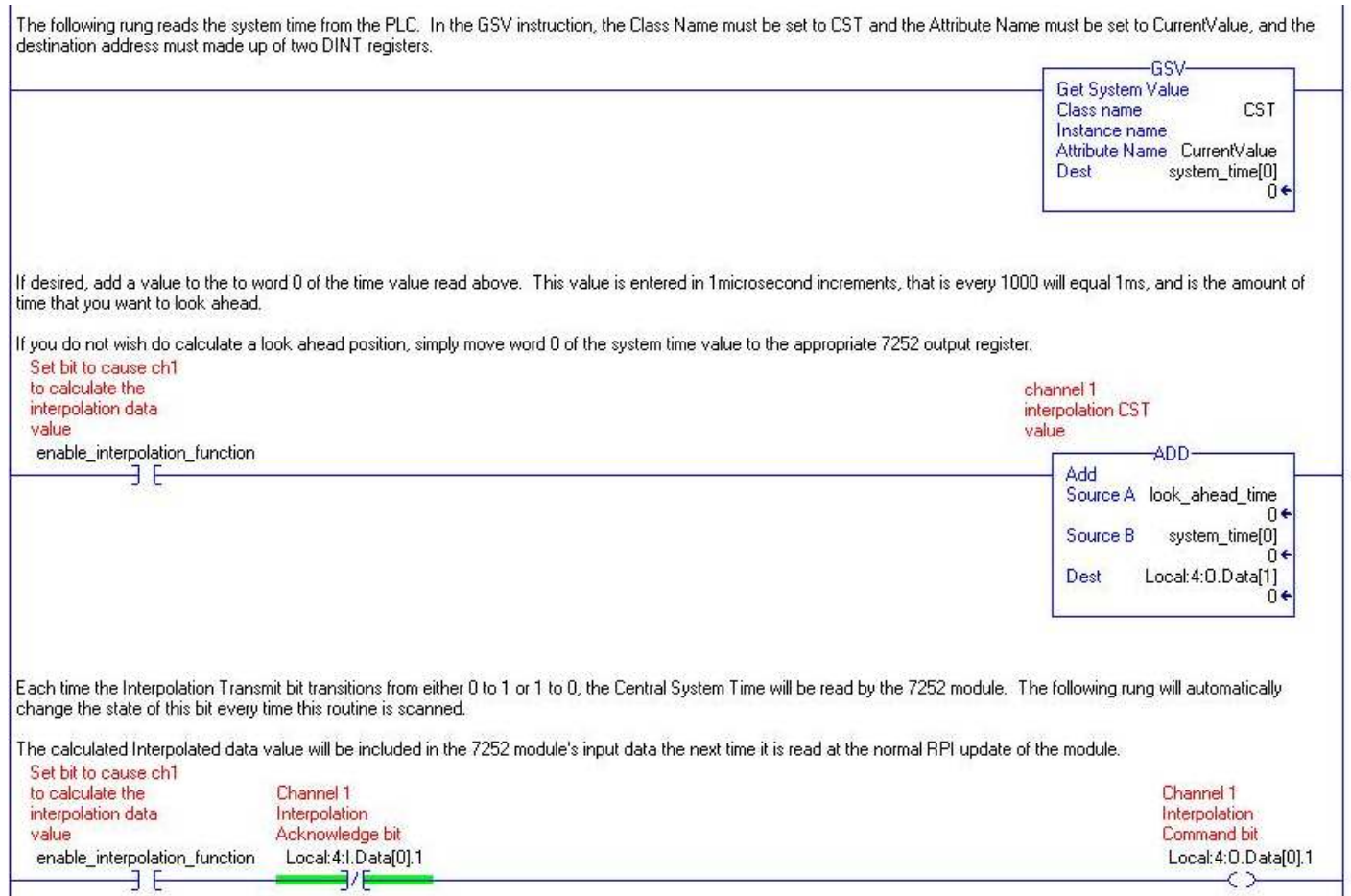



Chapter 8: Manual Revision History

Revision 0.0 was created 10/20/08 and was the initial release of the specifications.

Revision 1.0 was created on 1/30/09. The I/O and configuration words were updated.

Revision 1.1 was created on 2/20/09. Position data values ranges were updated.

Revision 1.2 was created on 3/9/09. Default Units Bit changed to 0 (inches). Was 1 (mm). Power up note added on page 18.