

DC25 SSI DuraCoder

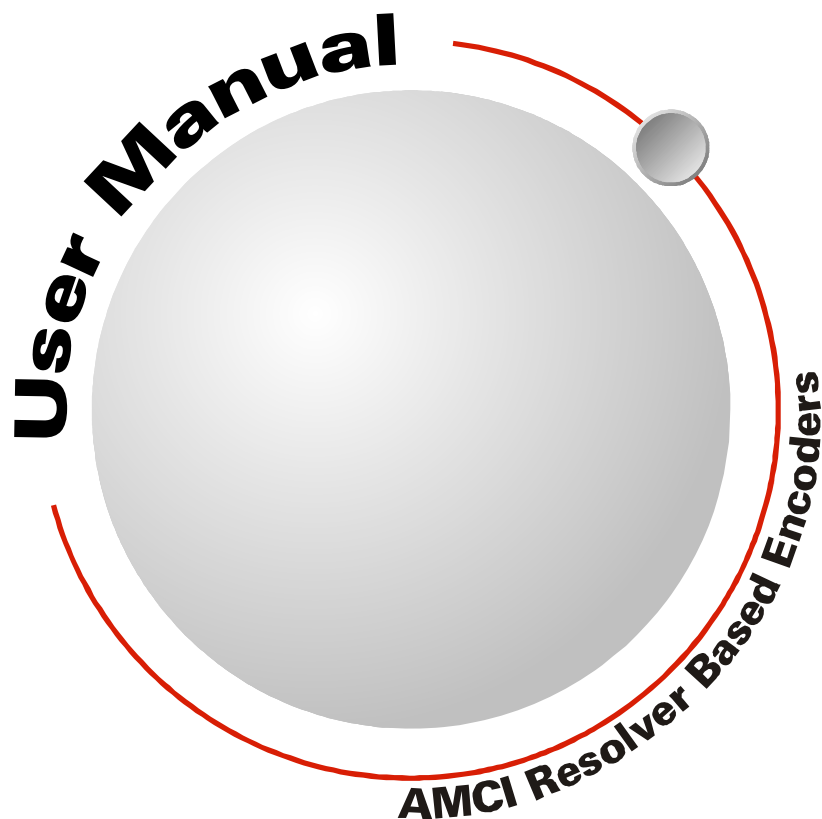

GENERAL INFORMATION

Important User Information

The products and application data described in this manual are useful in a wide variety of different applications. Therefore, the user and others responsible for applying these products described herein are responsible for determining the acceptability for each application. While efforts have been made to provide accurate information within this manual, AMCI assumes no responsibility for the application or the completeness of the information contained herein.

UNDER NO CIRCUMSTANCES WILL ADVANCED MICRO CONTROLS, INC. BE RESPONSIBLE OR LIABLE FOR ANY DAMAGES OR LOSSES, INCLUDING INDIRECT OR CONSEQUENTIAL DAMAGES OR LOSSES, ARISING FROM THE USE OF ANY INFORMATION CONTAINED WITHIN THIS MANUAL, OR THE USE OF ANY PRODUCTS OR SERVICES REFERENCED HEREIN.

No patent liability is assumed by AMCI, with respect to use of information, circuits, equipment, or software described in this manual.

The information contained within this manual is subject to change without notice.

This manual is copyright 2009 by Advanced Micro Controls Inc. You may reproduce this manual, in whole or in part, for your personal use, provided that this copyright notice is included. You may distribute copies of this complete manual in electronic format provided that they are unaltered from the version posted by Advanced Micro Controls Inc. on our official website: www.amci.com. You may incorporate portions of this documents in other literature for your own personal use provided that you include the notice "Portions of this document copyright 2009 by Advanced Micro Controls Inc." You may not alter the contents of this document or charge a fee for reproducing or distributing it.

Standard Warranty

ADVANCED MICRO CONTROLS, INC. warrants that all equipment manufactured by it will be free from defects, under normal use, in materials and workmanship for a period of [18] months. Within this warranty period, AMCI shall, at its option, repair or replace, free of charge, any equipment covered by this warranty which is returned, shipping charges prepaid, within eighteen months from date of invoice, and which upon examination proves to be defective in material or workmanship and not caused by accident, misuse, neglect, alteration, improper installation or improper testing.

The provisions of the "STANDARD WARRANTY" are the sole obligations of AMCI and excludes all other warranties expressed or implied. In no event shall AMCI be liable for incidental or consequential damages or for delay in performance of this warranty.

Returns Policy

All equipment being returned to AMCI for repair or replacement, regardless of warranty status, must have a Return Merchandise Authorization number issued by AMCI. Call (860) 585-1254 with the model number and serial number (if applicable) along with a description of the problem. A "RMA" number will be issued. Equipment must be shipped to AMCI with transportation charges prepaid. Title and risk of loss or damage remains with the customer until shipment is received by AMCI.

24 Hour Technical Support Number

24 Hour technical support is available on this product. If you have internet access, start at www.amci.com. Product documentation and FAQ's are available on the site that answer most common questions.

If you require additional technical support, call (860) 583-7271. Your call will be answered by the factory during regular business hours, Monday through Friday, 8AM - 5PM Eastern. During non-business hours an automated system will ask you to enter the telephone number you can be reached at. Please remember to include your area code. The system will page an engineer on call. Please have your product model number and a description of the problem ready before you call.

We Want Your Feedback

Manuals at AMCI are constantly evolving entities. Your questions and comments on this manual are both welcomed and necessary if this manual is to be improved. Please direct all comments to: Technical Documentation, AMCI, 20 Gear Drive, Terryville CT 06786, or fax us at (860) 584-1973. You can also e-mail your questions and comments to techsupport@amci.com

TABLE OF CONTENTS

General Information

Important User Information	2
Standard Warranty	2
Returns Policy	2
24 Hour Technical Support Number	2
We Want Your Feedback	2

About This Manual

Audience	5
Navigating this Manual	5
Manual Conventions	5
Trademarks and Other Legal Stuff	6
Revision Record	6
Revision History	6
Where To Go From Here	6

Chapter 1: Introduction To The SSI DuraCoder

SSI DuraCoder Overview	7
Programmable Parameters	8
SSI Data Format	8
Number of Turns	8
Number of Counts	8
Baud Rate	8
Electrical Specifications	9
Mechanical Specifications	9
Environmental Specifications	9
SSI DuraCoder Part	
Numbering System	10
SSI Data Transfer	10
Single Turn Transfer	10
Multi-turn Transfer	11
RS422/485 Data Transfer	11
Compatible Equipment	12

Chapter 2: Installing The SSI DuraCoder

Flange Mount Outline Drawings	13
Aluminum Body,	
End Connector	13
Aluminum Body,	
Side Connector	13
316 Stainless Steel Body	14
Alternate Shafts	14
Shaft Loading	14
Servo Mount Outline Drawings	15
Aluminum Body,	
End Connector	15
Aluminum Body,	
Side Connector	15
316 Stainless Steel Body	16
Alternate Shafts	16
Shaft Loading	16
Blind Shaft Mount Outline Drawings	17
Aluminum Body,	
End Connector	17
Aluminum Body,	
Side Connector	18
316 Stainless Steel Body	19
Available Shaft Diameters	19
Shaft Loading	19
5/8" Shaft Face Mount	
Outline Drawings	20
Aluminum Body,	
End Connector	20
Aluminum Body,	
Side Connector	21
316 Stainless Steel Body	22
Shaft Loading	22
Connector Pinouts	23
Aluminum Body Connector	23
316 Stainless Steel	
Body Connector	23
Cabling	24
CSL-(x) Cable	24
M12 Cordsets	24

**Chapter 3: Configuring The SSI
DuraCoder**

Required Equipment	25
RS422/485 Comm Port	25
Programming Cable	25
Programming Software	25
Configuring the RS485/422	
Comm Port	26
Check Which COM Ports	
Are In Use	26
USBCOM Driver CD	26
Driver Installation	26
Determine C485USB	
COM Port Address	26
I Can't Remember the	
COM Port Number!	27
Using the USBProgrammer.exe	
Program	27
Data Entry Fields	28
Command Buttons	28
Current Position Display	28

**Chapter 4: RS422/485
Communications**

RS422/485 Comm Port	29
DuraCoder Pinout	29
RS422/485 Default Parameters	30
Communications Protocol	30
Read Command	30
Read Response	31
Parameter Lengths, Ranges	
and Defaults	32
Setting the Baud Rate	32
Write Baud Rate Command	32
Write Baud Rate Response	33

ABOUT THIS MANUAL

Read this chapter to learn how to navigate through this manual and familiarize yourself with the conventions used in it. The last section of this chapter highlights the manual's remaining chapters and their target audience.

Audience

This manual explains the installation and operation of the SSI DuraCoders from AMCI. It is written for the engineer responsible for incorporating the SSI DuraCoder into a design as well as the engineer or technician responsible for its actual installation. If there are any unanswered questions after reading this manual, call the factory. An applications engineer will be available to assist you.

Navigating this Manual

This manual is designed to be used in both printed and on-line forms. Its on-line form is a PDF document, which requires Adobe Acrobat Reader version 6.0+ to open it.

Bookmarks of all the chapter names, section headings, and sub-headings are in the PDF file to help you navigate through it. The bookmarks should have appeared when you opened the file. If they didn't, press the F5 key on Windows platforms to bring them up.

Throughout this manual you will also find *blue text that functions as a hyperlink* in HTML documents. Clicking on the text will immediately jump you to the referenced section of the manual. If you are reading a printed manual, most links include page numbers.

The PDF file is password protected to prevent changes to the document. You are allowed to select and copy sections for use in other documents and, if you own Adobe Acrobat version 4.05 or later, you are allowed to add notes and annotations.

Manual Conventions

Three icons are used to highlight important information in the manual:



NOTES highlight important concepts, decisions you must make, or the implications of those decisions.



CAUTIONS tell you when equipment may be damaged if the procedure is not followed properly.



WARNINGS tell you when people may be hurt or equipment may be damaged if the procedure is not followed properly.

The following table shows the text formatting conventions:

Format	Description
Normal Font	Font used throughout this manual.
<i>Emphasis Font</i>	Font used the first time a new term is introduced.
<i>Cross Reference</i>	When viewing the PDF version of the manual, clicking on the cross reference text jumps you to referenced section.

Trademarks and Other Legal Stuff

The AMCI logo is a trademark, and “AMCI” and “DuraCoder” are registered trademarks of Advanced Micro Controls Inc. “Adobe” and “Acrobat” are registered trademarks of Adobe Systems Incorporated.

All other trademarks contained herein are the property of their respective holders.

Revision Record

This manual, 940-0D061, is the second release of this manual. It was initially released October 14, 2009. It adds specifications and outline drawings for the stainless steel DuraCoders.

Revision History

940-0D060: 4/27/2009. Initial Release.

Where To Go From Here

This manual contains information that is of interest to everyone from engineers to operators. The table below gives a brief description of each chapter’s contents to help you find the information you need to do your job.

CHP Num.	Chapter Title	Chapter Description
1	<i>INTRODUCTION TO THE SSI DURACODER</i>	Intended for anyone new to the SSI DuraCoder, this chapter gives a basic overview of the unit, including an explanation of its programmable features. The chapter also explains the SSI DuraCoder part numbering system and lists complementary equipment available from AMCI.
2	<i>CONFIGURING THE SSI DURACODER</i>	Intended for anyone responsible for configuring an SSI DuraCoder before it is used in an application, this chapter explains how to download, install, and use AMCI programming software to configure an SSI DuraCoder.
3	<i>INSTALLING THE SSI DURACODER</i>	This chapter is intended for the engineer or technician responsible for installing and wiring the SSI DuraCoder. Information in this chapter includes mechanical drawings, connector pin out and wiring diagrams.
4	<i>RS422/485 COMMUNICATIONS</i>	This chapter is intended for anyone responsible for interfacing with the SSI DuraCoder over the RS422/485 link.

INTRODUCTION TO THE SSI DURACODER

SSI DuraCoder Overview

Simply put, DuraCoders are designed to be the most durable encoders on the market today. Instead of being designed around a disk and optics like an optical encoder, each DuraCoder uses a resolver as its primary shaft position sensor. The resolver is an analog device whose outputs vary sinusoidally as the shaft is rotated. Constructed in a manner similar to high precision motors, resolvers are absolute, single turn position sensors that are unsurpassed in terms of ruggedness and reliability.

Originally designed for military applications over 60 years ago, resolvers have gained popularity in many industrial markets from steel mills to presses to packaging machines. If you are interested in learning more about resolvers, check out our website at:

<http://www.amci.com/tutorials/tutorials-what-is-resolver.asp>

The resolver's analog signals are decoded into a 12 bit position value by industrial grade electronics incorporated into the DuraCoder. This 12 bit (4096 count) position value is available as SSI data. In addition to the standard SSI interface, the DuraCoder also has a RS422/485 communications port. This interface is primarily used to program the DuraCoder but it can also be used to read the position value into a computer or other industrial device that does not have an SSI interface.

Two versions of the SSI DuraCoder are available. The first is a single turn device that has a maximum position resolution of 4096 counts per turn. The number of counts per turn is programmable from 2 to 4096 counts and the format of the SSI data can be programmed to Binary or Gray Code. The SSI data is transmitted using a thirteen bit transfer, identical to the transfer used by Allen-Bradley 842 and Stegman encoders.

The second version is a multi-turn device that has a maximum of 4096 counts per turn and can encode a maximum of 4096 turns. Similar to the single turn unit, you can program the total number of counts you want and the total number of turns for those counts. The position value is transmitted using a twenty-four bit transfer and the data format can be set to Binary or Gray Code.

Both the single and multi-turn versions are available in a variety of industry standard size 25 optical encoder packages. A multi-turn flange mount unit with a 3/8 inch shaft a side mount connector is shown above. Servo mount and end connect units are also available. If your application requires you to mount a DuraCoder to a motor shaft, a blind shaft option is available as well. Finally, a face mount unit with a 5/8 inch shaft is available for applications that may be exposed to high shaft loads. This 5/8 inch shaft option is not an industry standard and is available only from AMCI.

All of the DuraCoders allow you to reset the position value to zero by momentarily connecting one of the connector pins to +Vdc. Multi-turn units with the connector on the side can be ordered with a sealed push button on the end of the unit that can be used to reset the position value.

In addition to our standard IP67 DuraCoders with powder-coated aluminum bodies, Incremental DuraCoders are also available in 316 stainless steel for use in food grade, marine, or corrosive environments.

Outline drawings of all the packaging options is available in the *Outline Drawings* section of the ***INSTALLING THE SSI DURACODER*** chapter, starting on page 13.



Figure 1.1 SSI DuraCoder



Programmable Parameters

There are several programmable parameters that allow you to configure the SSI DuraCoder to match your application. These parameters are set over the RS485 link using a Microsoft Windows based program available from AMCI. These values are stored in non-volatile memory.

SSI Data Format

This parameter specifies the format of the position data transmitted over the SSI interface. Your choices are *Natural Binary* or *Gray Code*. Natural Binary is the default and is suggested for all new applications. Gray Code has been included primarily to make the SSI DuraCoder compatible with pre-existing applications.



If the SSI Data Format is set to *Gray Code*, the Number of Counts parameter (see below) must be programmed to a power of two.

Number of Turns

Available on the multi-turn SSI DuraCoder only, this parameter specifies the number of turns the input shaft must complete before the position value reaches its maximum count and rolls over to zero. It can be programmed to any power of two between 1 and 4,096. (1, 2, 4, 8, 16, 32, 64, 128, 256, 1024, 2048, 4096) The factory default value is 4,096

Number of Counts

Sets the number of counts the DuraCoder will produce over the programmed number of turns. The minimum value for the Number of Counts parameter is two. The maximum value is equal to 4,096 multiplied by the programmed Number of Turns. For single turn units, the range for this parameter is 2 to 4,096. For multi-turn units, the range is 2 to (4,096 * programmed Number of Turns). The factory default values are 4,096 for single turn units and 16,777,216 (4,096*4,096) for multi-turn units. If you decide to use Gray Code as your SSI Data Format, the Number of Counts must be programmed to a power of two.



This parameter sets the total number of counts, not the maximum count. If you are measuring a rotary position and you want to measure in degrees, you would set the Number of Counts parameter to 360, not 359. In this case, the SSI DuraCoder will produce 360 counts, with a range of 0 to 359.

Baud Rate

Used to set the baud rate of the RS422/485 communications port. Generally not set unless you are reading position data over the RS422/485 interface instead of the SSI interface, this parameter defaults to 9600 baud. The baud rate is reset to 9600 baud on every power up to ensure that a user can easily interface with the SSI DuraCoder. The DuraCoder can be programmed to any of the following baud rates: 1200, 2400, 4800, 9600, 19200, 38400, 57600, and 115200.

**Electrical Specifications****Operating Voltage**

4.5Vdc to 30Vdc

Power Requirements

2.0W max.

70mA @ 24Vdc optimal

Single Turn Output Format

13 bit SSI (\pm clock \pm data)

Multi-turn Output Format

24 bit SSI (\pm clock \pm data)

Code Format

Programmable Natural Binary or Gray Code

Counts per Turn

Programmable 2 to 4096

Number of Turns

Programmable 2, 4, 8, 16, 32, 64, 128, 256, 512, 1024, 2048, or 4096. (Multi-turn only)

Programmable Full Scale Count

2^{12} – Single Turn

2^{24} – Multi-turn

Direction of Increasing Counts

Default of CW increasing when looking at the shaft.

CCW increasing when power is applied to the Direction Input pin on power up.

Reset Position to Zero

100mS positive pulse on Reset Input

Reset life of 8.3 million cycles min.

Direction and Reset Input Electrical Specs

OFF Voltage = 0 to (0.2* DC Supply)

ON Voltage = (0.8* DC Supply) to DC Supply

Inputs require 3.5mA to activate

Mechanical Specifications**Package Style**

2.5 inch housing with flange or servo mounting

Connector Location

Side or End

Housing

Powder coated aluminum or 316 stainless steel

Mechanical Specifications (cont'd)**Shaft**

0.250", 0.375", 0.625", or 10 mm

Blind shaft with 0.375", 0.500", 10mm or 12mm hole

Max. Starting Torque @ 25°C

2.0 oz-in: 0.250", 0.375", and 10 mm shafts

6.0 oz-in: All blind shafts

6.0 oz-in: 0.625" shaft

Moment of Inertia (oz-in-sec²)

6.00×10^{-4} : 0.250", 0.375", and 10 mm shafts

7.00×10^{-4} : All blind shafts

8.50×10^{-4} : 0.625" shaft

Max. Operating Speed

6000 RPM max.

Max. Shaft Loading (0.625" shaft)

Axial: 50lbs. (222N)

Radial: 100lbs. (445N)

At specified max. loads, bearing life is 2×10^9 revolutions min.

Max. Shaft Loading (All other shafts)

Axial: 20lbs. (89N)

Radial: 40lbs. (178N)

At specified max. loads, bearing life is 2×10^9 revolutions min.

Environmental Specifications**Operating Temperature**

-40°F to +185°F (-40°C to +85°C)

Shock

50g, 11 millisecond duration

Vibration

20g, 5 to 2000Hz

Enclosure Rating

IP67

Approximate Weight

2.0lbs. (0.91kg) 0.625" shaft - Aluminum Body

3.8lbs. (1.73kg) 0.625" shaft - 316 Steel Body

1.4lbs. (0.65kg) All other shafts - Aluminum Body

2.9lbs. (1.32kg) All other shafts - 316 Steel Body

SSI DuraCoder Part Numbering System

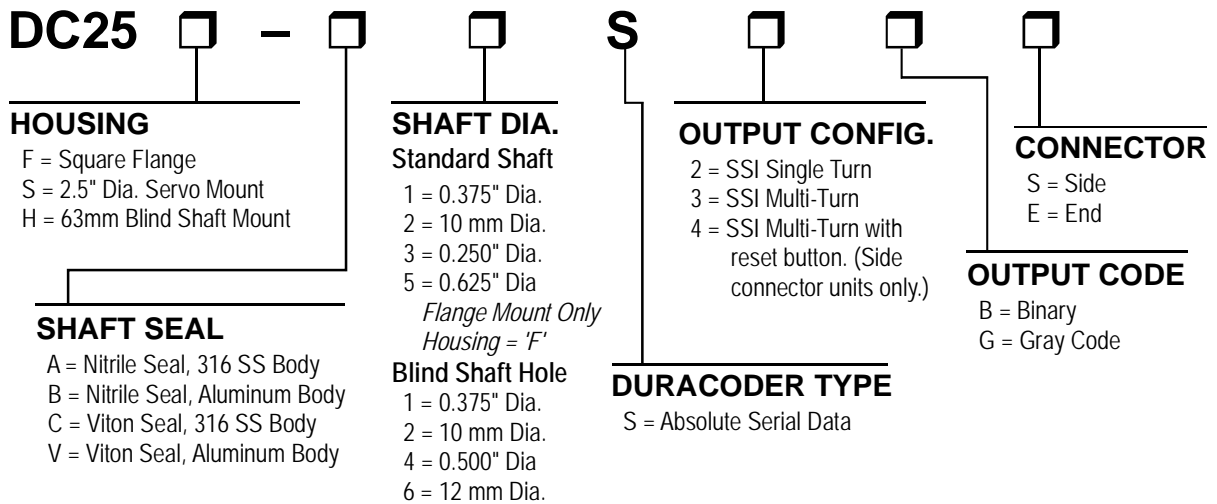
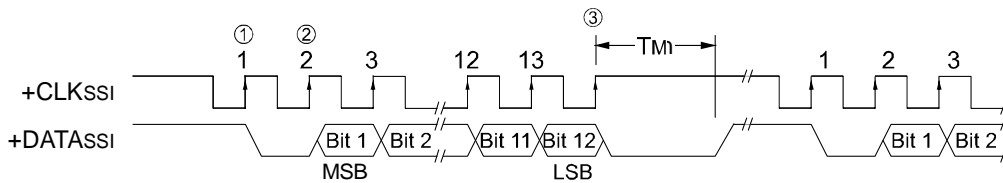

Figure 1.2 SSI DuraCoder Part Number

SSI Data Transfer

The diagrams below show the timing diagrams of the single turn and multi-turn position values.

Single Turn Transfer



- ① The position data is internally updated every 20 microseconds. On the first rising edge of the SSI clock, the position data is latched and a zero is placed on the DATASSI line. This is actually the first SSI data bit which will always be zero because the maximum position value from a DuraCoder is 12 bits and the SSI transfer is 13 bits.
- ② The DuraCoder responds to the next twelve rising edges of the clock by placing the position data bits on the DATASSI line, most significant digit first. Note that these rising edges are numbered 2 through 13 in the diagram above.
- ③ The next rising clock edge signals the end of the transfer. The DuraCoder will hold the DATASSI line in a logic zero state for the T_m time, which is 20 to 25 microseconds. At this point, the DuraCoder drives the DATASSI line to a logic one state to signal that it is ready for another transfer.

NOTE

- ① The minimum allowable SSI clock frequency is 25KHz at a 50% duty cycle. This translates into a maximum on or off time of 20 microseconds. If this time is exceeded, the DuraCoder will refresh its position value and the next positive clock edge will start a new transfer. The maximum allowable clock frequency is 1 MHz.
- ② If more than thirteen clock pulses are applied during one transfer, the DuraCoder will continue to output a logic zero. This will be maintained for a total of thirty-two clock pulses, at which time the output becomes indeterminate.

Figure 1.3 SSI Data Transfer: Single Turn



SSI Data Transfer (Continued)

Multi-turn Transfer

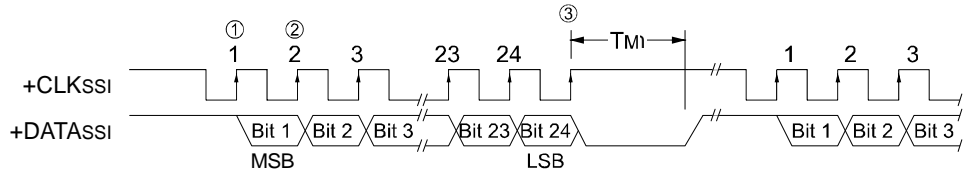

- ① The position data is internally updated every 20 microseconds. On the first rising edge of the SSI clock, the position data is latched and the MSB is placed on the DATASSI line.
- ② The DuraCoder responds to the next twenty-three rising edges of the clock by placing the remaining position data bits on the DATASSI line. Note that these rising edges are numbered 2 through 24 in the diagram above.
- ③ The next rising clock edge signals the end of the transfer. The DuraCoder will hold the DATASSI line in a logic zero state for the T_M time, which is 20 to 25 microseconds. At this point, the DuraCoder drives the DATASSI line to a logic one state to signal that it is ready for another transfer.

NOTE

- ① The multi-turn SSI DuraCoder always uses twenty-four bit transfers, even if your programmed Full Scale Count is less than twenty-four bits long.
- ② The minimum allowable SSI clock frequency is 25KHz at a 50% duty cycle. This translates into a maximum on or off time of 20 microseconds. If this time is exceeded, the DuraCoder will refresh its position value and the next positive clock edge will start a new transfer. The maximum allowable clock frequency is 1 MHz.
- ③ If more than twenty-four clock pulses are applied during one transfer, the DuraCoder will continue to output a logic zero. This will be maintained for a total of thirty-two clock pulses, at which time the output becomes indeterminate.

Figure 1.4 SSI Data Transfer: Multi-Turn

RS422/485 Data Transfer

The SSI DuraCoder has a full duplex RS422/485 interface that is used when programming the setup parameters on the unit. You can also use this serial link to interface your SSI DuraCoder to a controller that does not have an SSI communications card.

The DuraCoder uses a simple polling protocol to exchange information over the RS422/485 link. When reading parameter values or the position data, your program must write a four byte command to the DuraCoder. The DuraCoder immediately responds with the requested information. The DuraCoder then waits for the next request before sending any additional information.

The default baud rate is 9600 baud, but it can be programmed to values up to 115.2K. The baud rate is reset to 9600 on every power up.

Further information on the RS422/485 link can be found in chapter 4 starting on page29.



Compatible Equipment

The SSI DuraCoder is the first SSI sensor released by AMCI, but we have been manufacturing SSI Interface Modules for years. Below is a list of SSI Interface Modules that was current at the release of this manual. If you do not see a compatible device listed, contact AMCI or visit our website (<http://www.amci.com>) to see if any other SSI interface devices have been added.

Part Number	Platform	Description
7161	A-B MicroLogix 1100, 1200, 1400	One Channel SSI Interface Module Supports transfers up to 32 bits long.
7162	A-B MicroLogix 1100, 1200, 1400	Two Channel SSI Interface Module Supports transfers up to 32 bits long.
7262	A-B ControlLogix	Two Channel SSI Interface Module Supports transfers up to 32 bits long.
7264	A-B ControlLogix	Four Channel SSI Interface Module Supports transfers up to 32 bits long.
7361	GE Fanuc Series90-30 and PAC Rx3	One Channel SSI Interface Module Supports 24/25 bit transfers.
7561	A-B SLC 500	One Channel SSI Interface Module Supports 24/25 bit transfers.
7662	A-B CompactLogix A-B MicroLogix 1500	Two Channel SSI Interface Module Supports transfers up to 32 bits long.
7761H	A-B PLC-5 Platform	Single Channel SSI Interface Module Supports transfers up to 32 bits long.
7961	GE Fanuc Series90-70 and PAC Rx7	Single Channel SSI Interface Module Supports transfers up to 32 bits long.
NX2E4C	ControlNet Network	Four Channel SSI Interface Unit Supports transfers up to 32 bits long.
NX2E4E	EtherNet/IP Network	Four Channel SSI Interface Unit Supports transfers up to 32 bits long.
NX2E4P	Profibus Network	Four Channel SSI Interface Unit Supports transfers up to 32 bits long.
NX2E4D	DeviceNet Network	Four Channel SSI Interface Unit Supports transfers up to 32 bits long.
NX2E4T	Modbus TCP/IP Network	Four Channel SSI Interface Unit Supports transfers up to 32 bits long.

Table 1.1 Compatible AMCI Equipment

CHAPTER 2

INSTALLING THE SSI DURACODER

Flange Mount Outline Drawings

Aluminum Body, End Connector

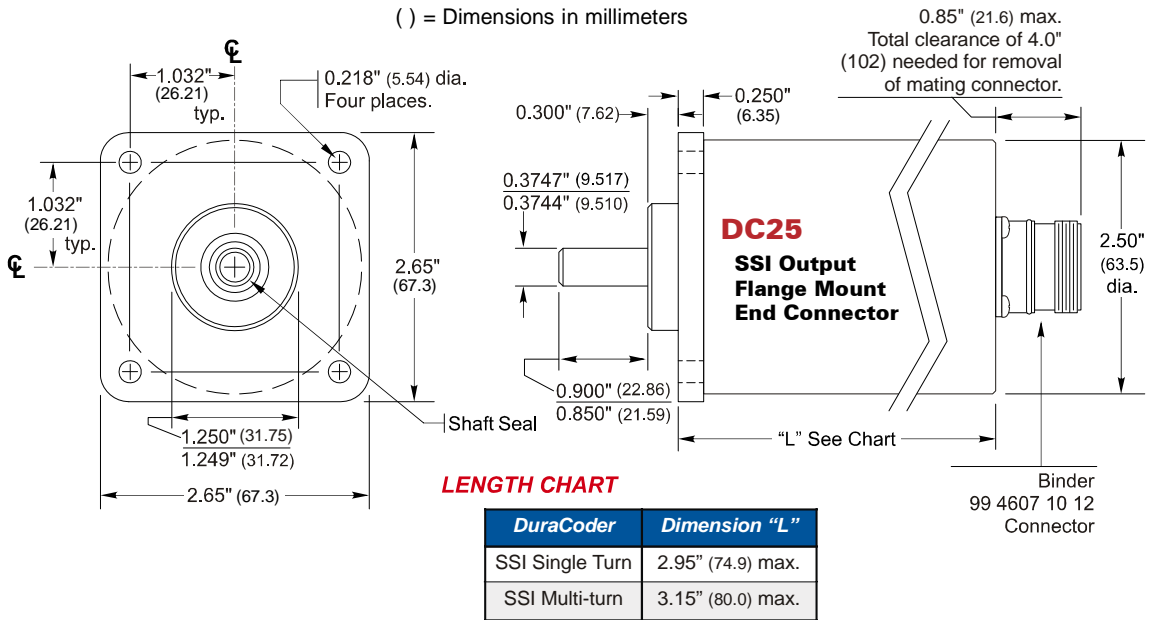

Figure 2.1 Aluminum Body, Flange Mount, End Connector Outline Drawing

Aluminum Body, Side Connector

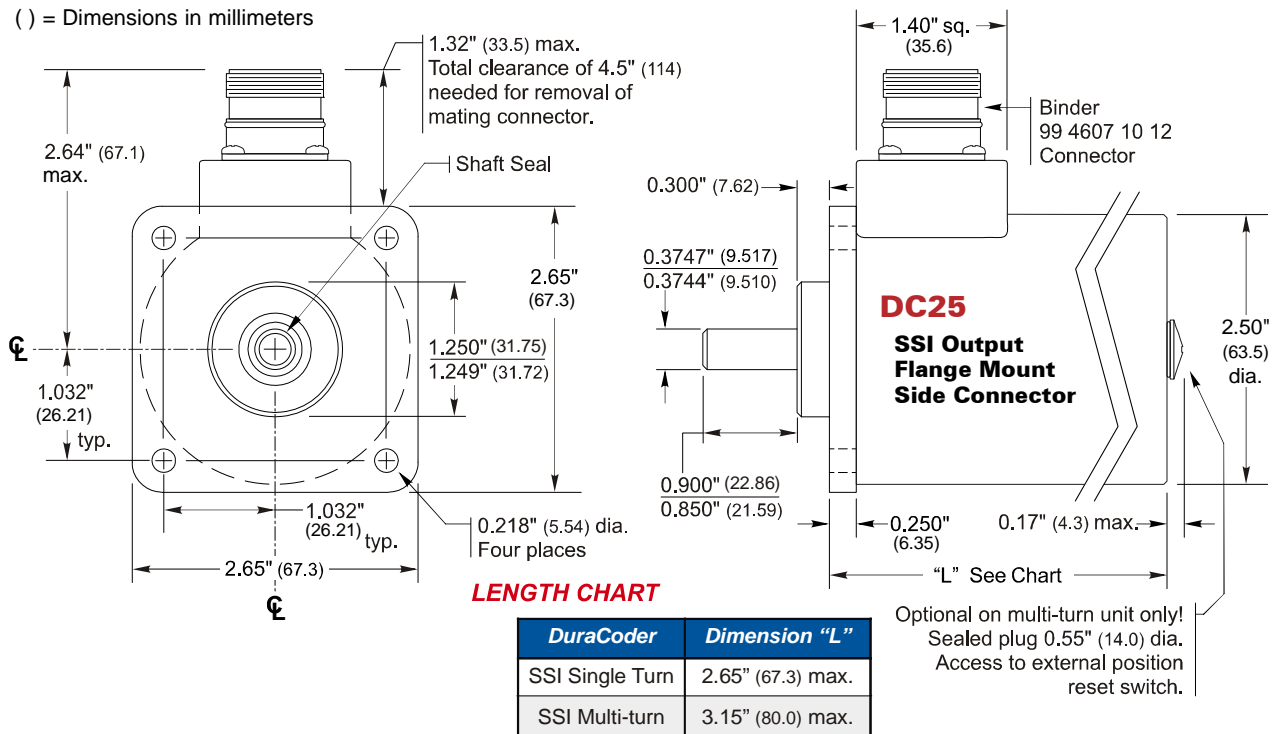

Figure 2.2 Aluminum Body, Flange Mount, Side Connector Outline Drawing

Flange Mount Outline Drawings (continued)

316 Stainless Steel Body

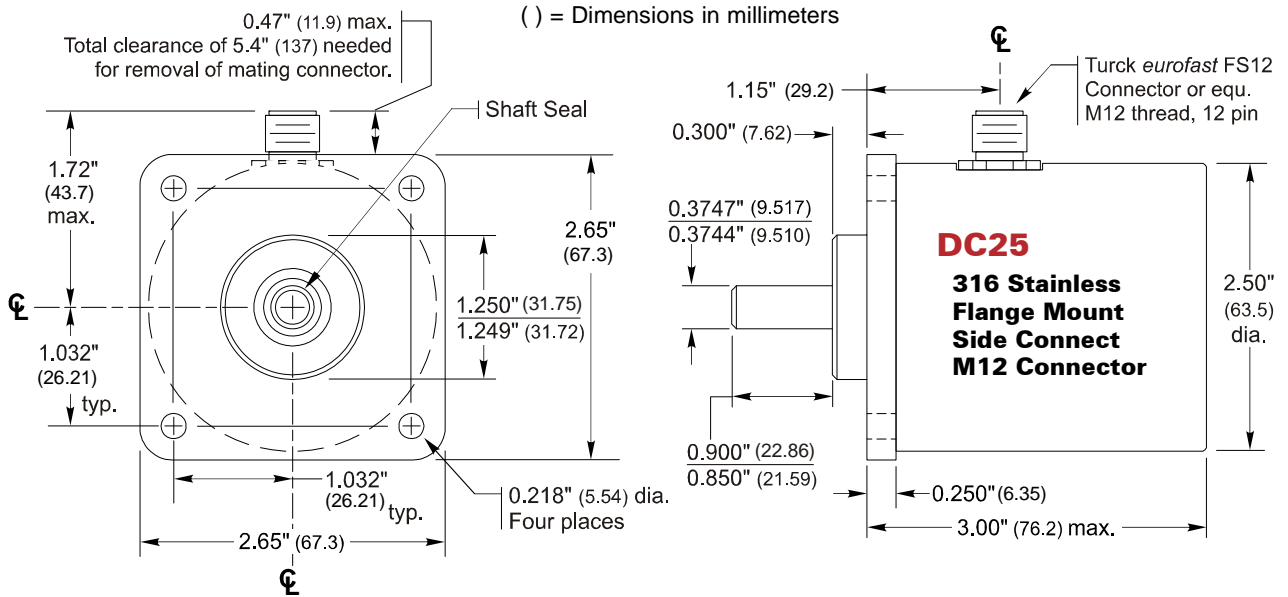
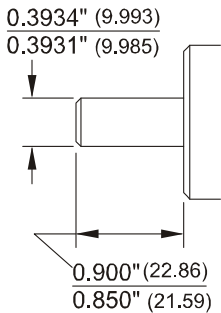

Figure 2.3 316 Stainless Steel Body, Flange Mount Outline Drawing

Alternate Shafts

10mm Shaft (Shaft Option 2)



1/4" Shaft (Shaft Option 3)

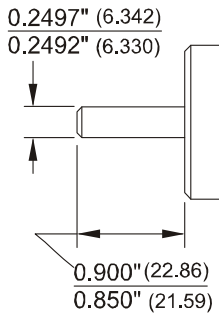

()=Dimensions in mm

Figure 2.4 Flange Mount Alternate Shafts

Shaft Loading

Limit shaft loading to the following values. These values statistically yield an L10 life of 2×10^9 revolutions. (Statistically, only 10% of the bearings will fail after 2×10^9 revolutions.) Shaft loading has an exponential effect on bearing life. The bearings will statistically last longer if you can limit shaft loading below the given values. Consider using the 5/8" shaft DuraCoder from AMCI if your shaft loading is expected to be greater than the values given below. Outline drawing for the 5/8" shaft DuraCoders start on page 20.

Radial Load	Axial Load
40 lbs. (178 N)	20 lbs. (88 N)

Table 2.1 Flange Mount Shaft Loading

Servo Mount Outline Drawings

Aluminum Body, End Connector

() = Dimensions in millimeters

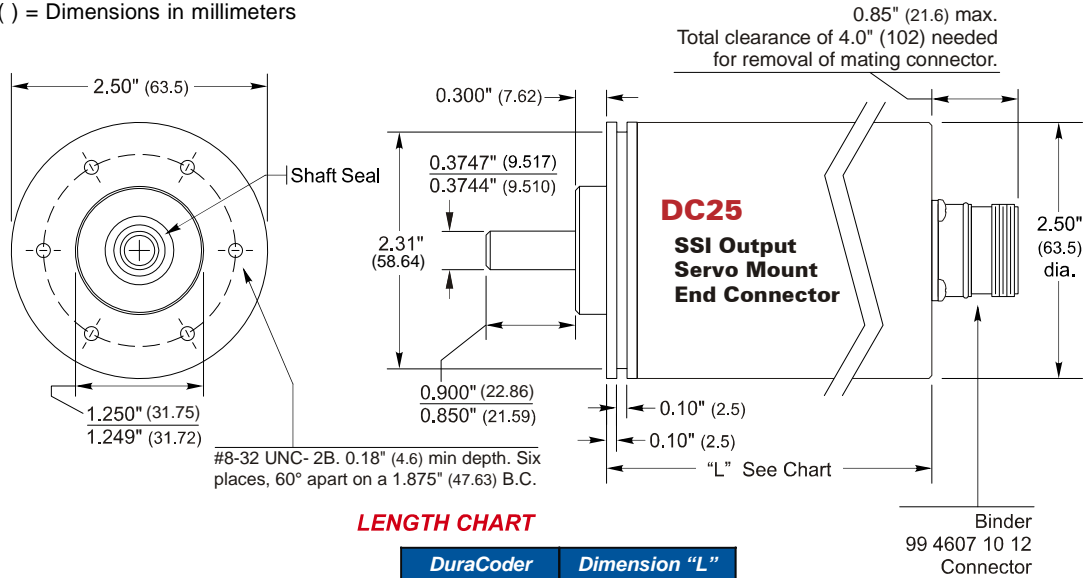

Figure 2.5 Aluminum Body, Servo Mount, End Connector Outline Drawing

Aluminum Body, Side Connector

() = Dimensions in millimeters

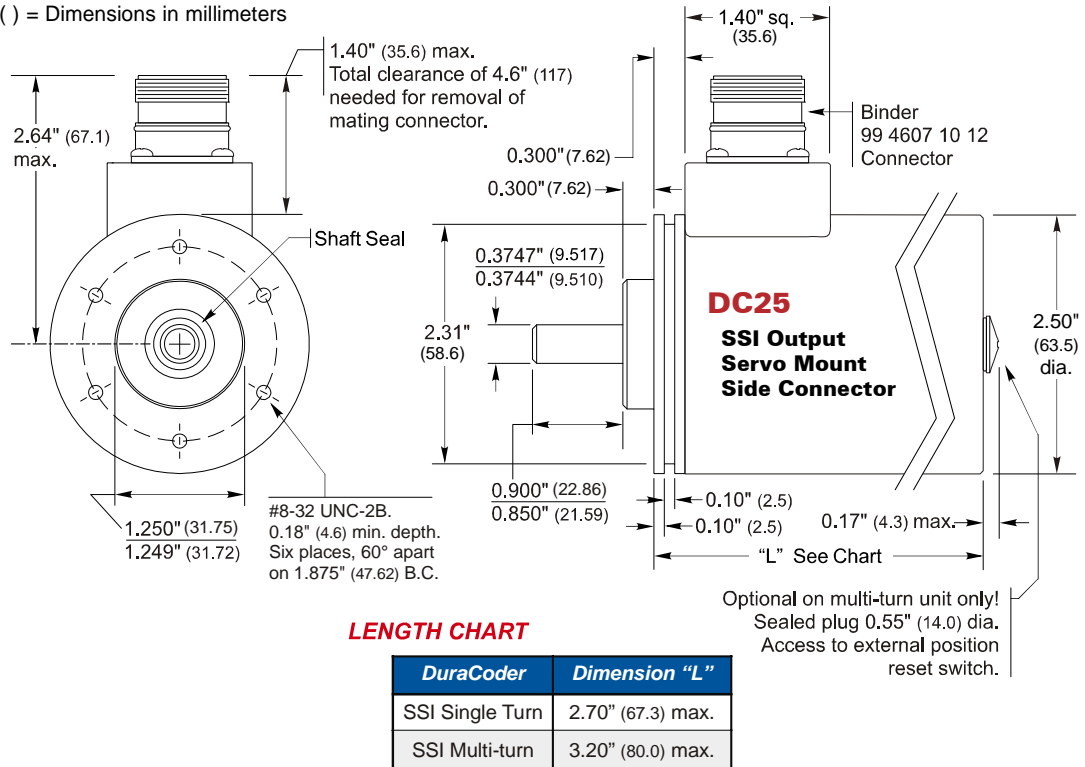

Figure 2.6 Aluminum Body, Servo Mount, Side Connector Outline Drawing

Servo Mount Outline Drawings (continued)

316 Stainless Steel Body

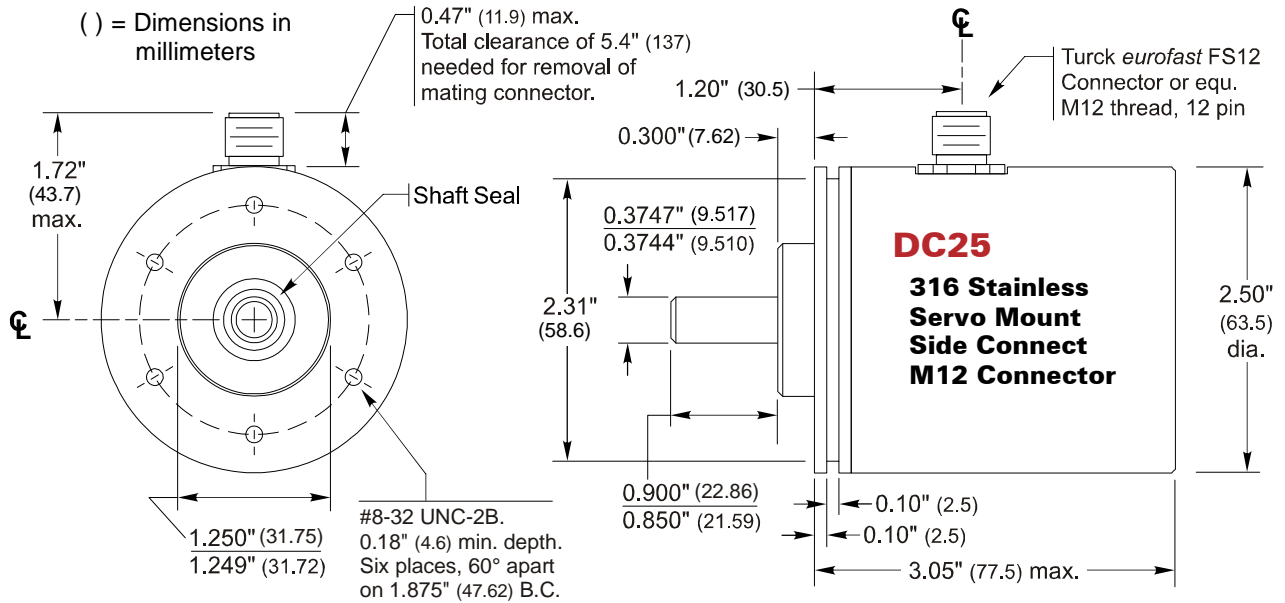
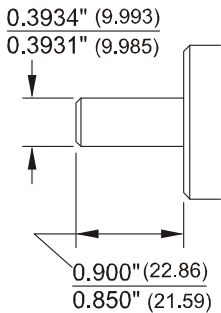

Figure 2.7 316 Stainless Steel Body, Servo Mount Outline Drawing

Alternate Shafts

10mm Shaft (Shaft Option 2)



1/4" Shaft (Shaft Option 3)

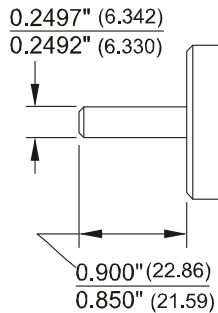

()=Dimensions in mm

Figure 2.8 Servo Mount Alternate Shafts

Shaft Loading

Limit shaft loading to the following values. These values statistically yield an L10 life of 2×10^9 revolutions. (Statistically, only 10% of the bearings will fail after 2×10^9 revolutions.) Shaft loading has an exponential effect on bearing life. The bearings will statistically last longer if you can limit shaft loading below the given values. Consider using the 5/8" shaft DuraCoder from AMCI if your shaft loading is expected to be greater than the values given below. Outline drawing for the 5/8" shaft DuraCoders start on page 20.

Radial Load	Axial Load
40 lbs. (178 N)	20 lbs. (88 N)

Table 2.2 Servo Mount Shaft Loading

Blind Shaft Mount Outline Drawings

Aluminum Body, End Connector

() = Dimensions in millimeters

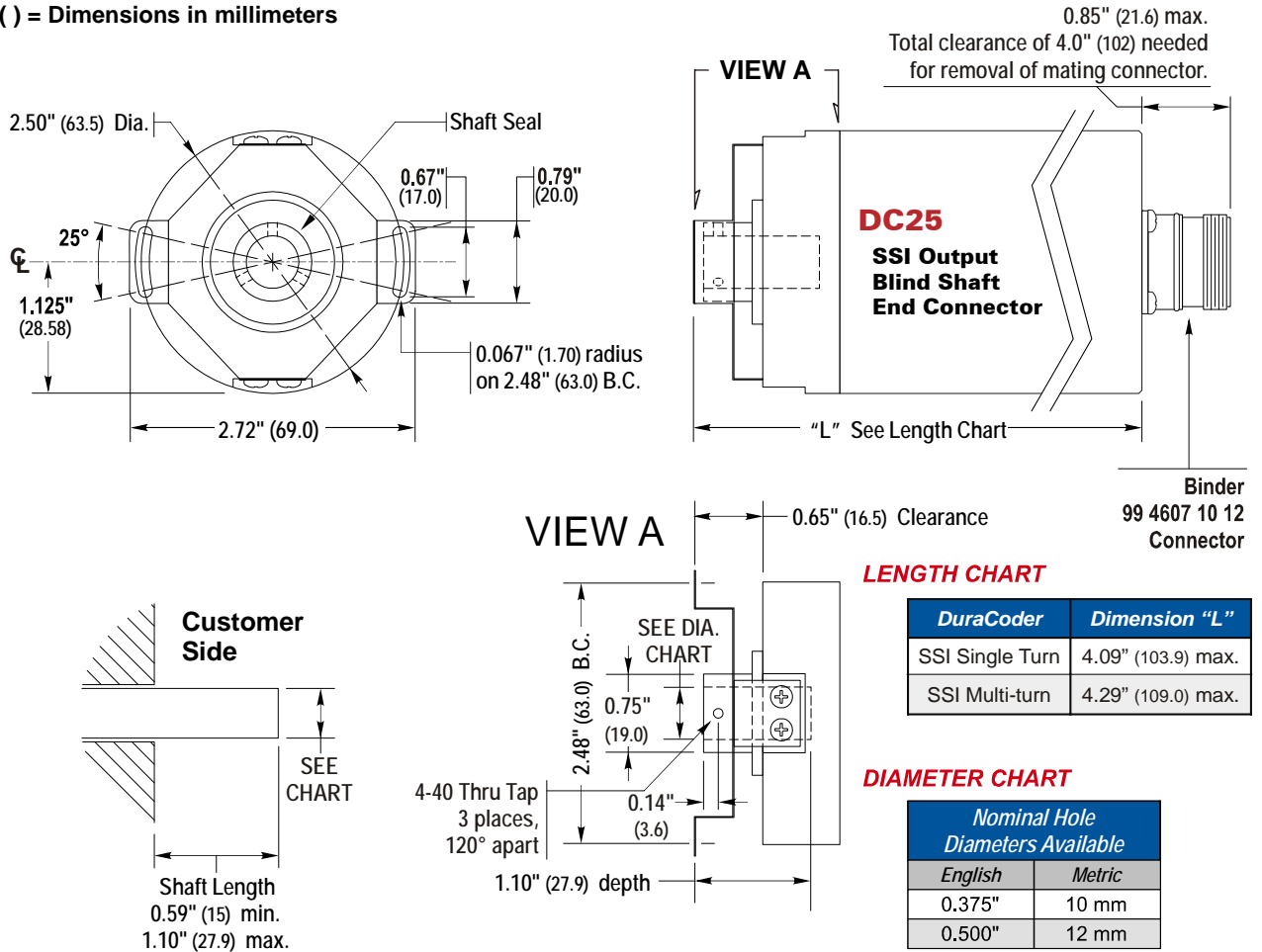

Figure 2.9 Aluminum Body, Blind Shaft Mount, End Connector Outline Drawing

Blind Shaft Mount Outline Drawings (continued)

Aluminum Body, Side Connector

() = Dimensions in millimeters

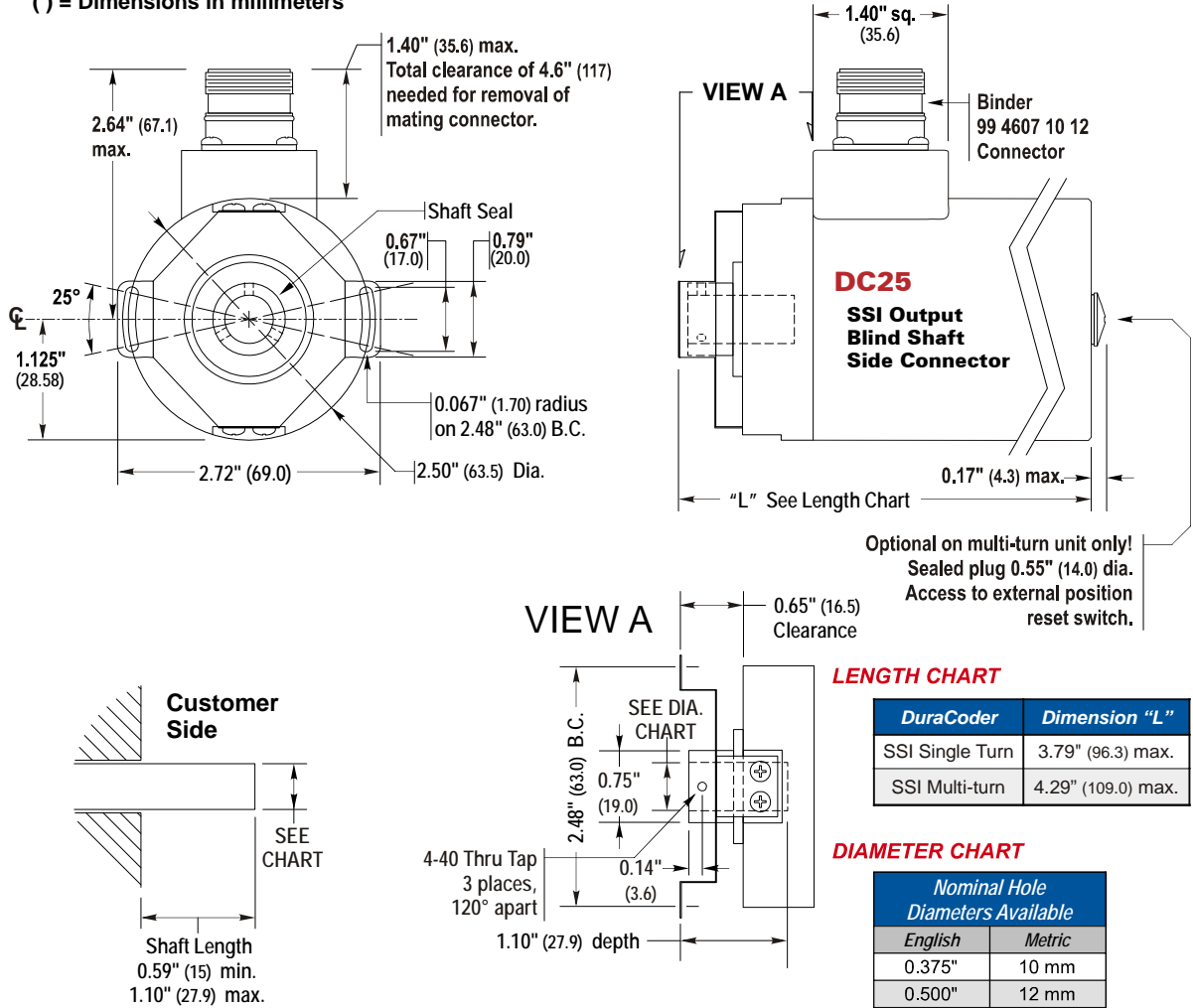

Figure 2.10 Aluminum Body, Blind Shaft Mount, Side Connector Outline Drawing

Blind Shaft Mount Outline Drawings (continued)

316 Stainless Steel Body

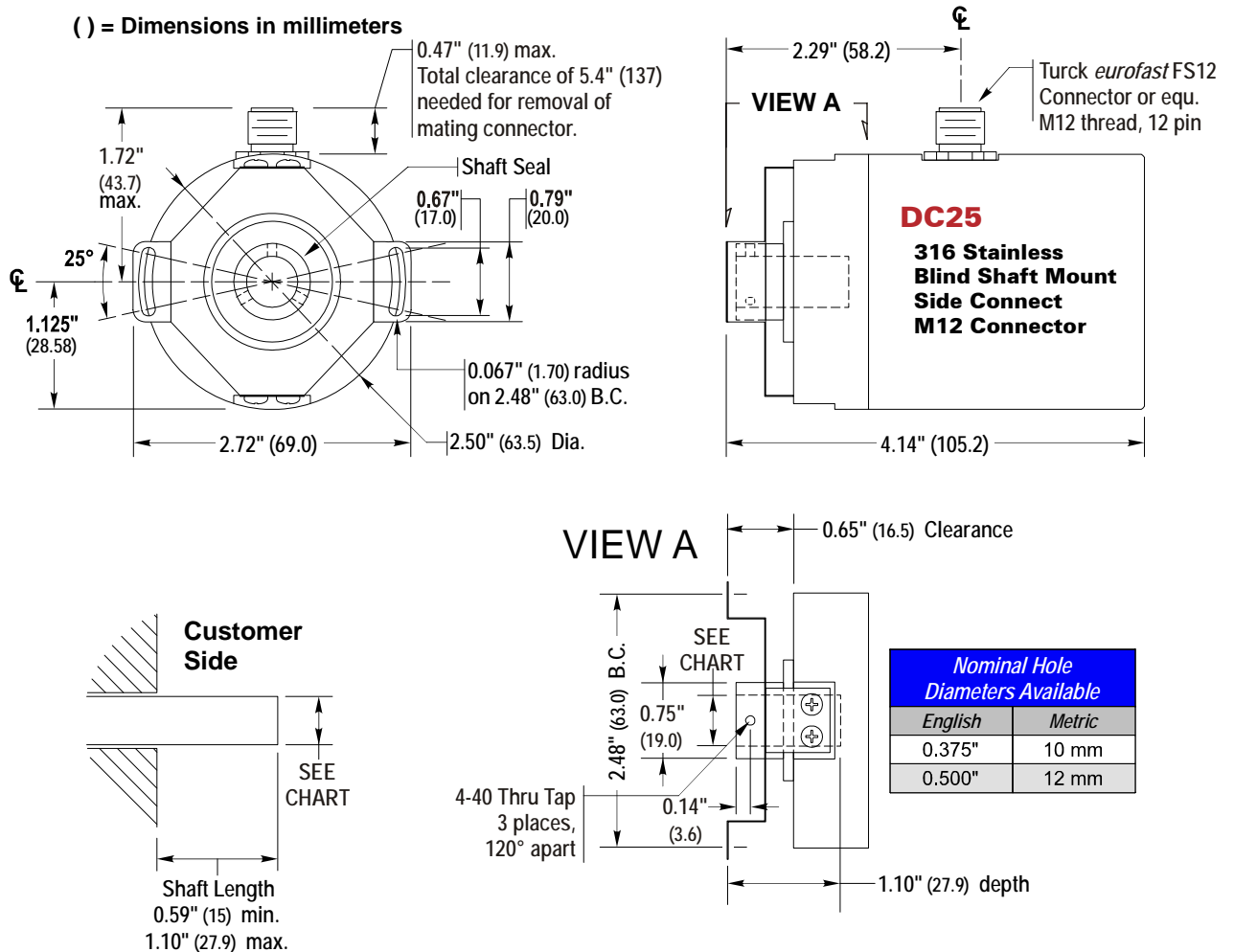

Figure 2.11 316 Stainless Steel Body, Blind Shaft Mount, Side Connector Outline Drawing

Available Shaft Diameters

The diameter of the drive shaft must be specified when ordering a blind shaft DuraCoder. Available options are given in the table below. Other diameter options may have become available after the release of this manual. Please check our website, www.amci.com, if you do not see the shaft diameter that fits your application.

Nominal Hole Diameters	
English	Metric
0.375"	10 mm
0.500"	12 mm

Table 2.3 Available Blind Shaft Diameters

Shaft Loading

The load that the SSI DuraCoder presents to your input shaft, which is equal to the load presented to the DuraCoder by your input shaft, is difficult to calculate and is dependent on the accuracy of the mounting. The flexible metal mounting bracket will be able to absorb most radial loading forces, but accurate mounting of the DuraCoder is important.

5/8" Shaft Face Mount Outline Drawings

Aluminum Body, End Connector

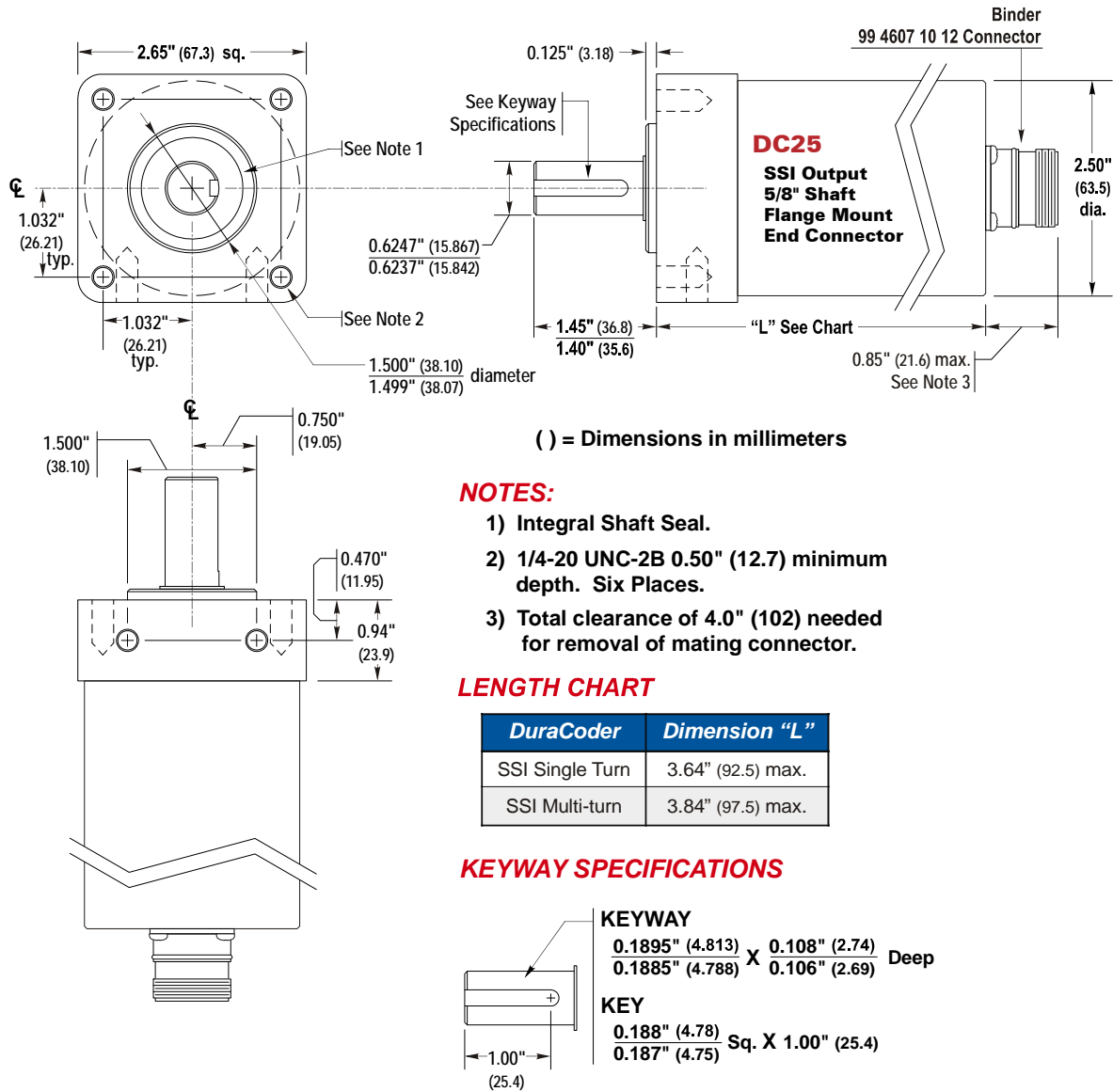
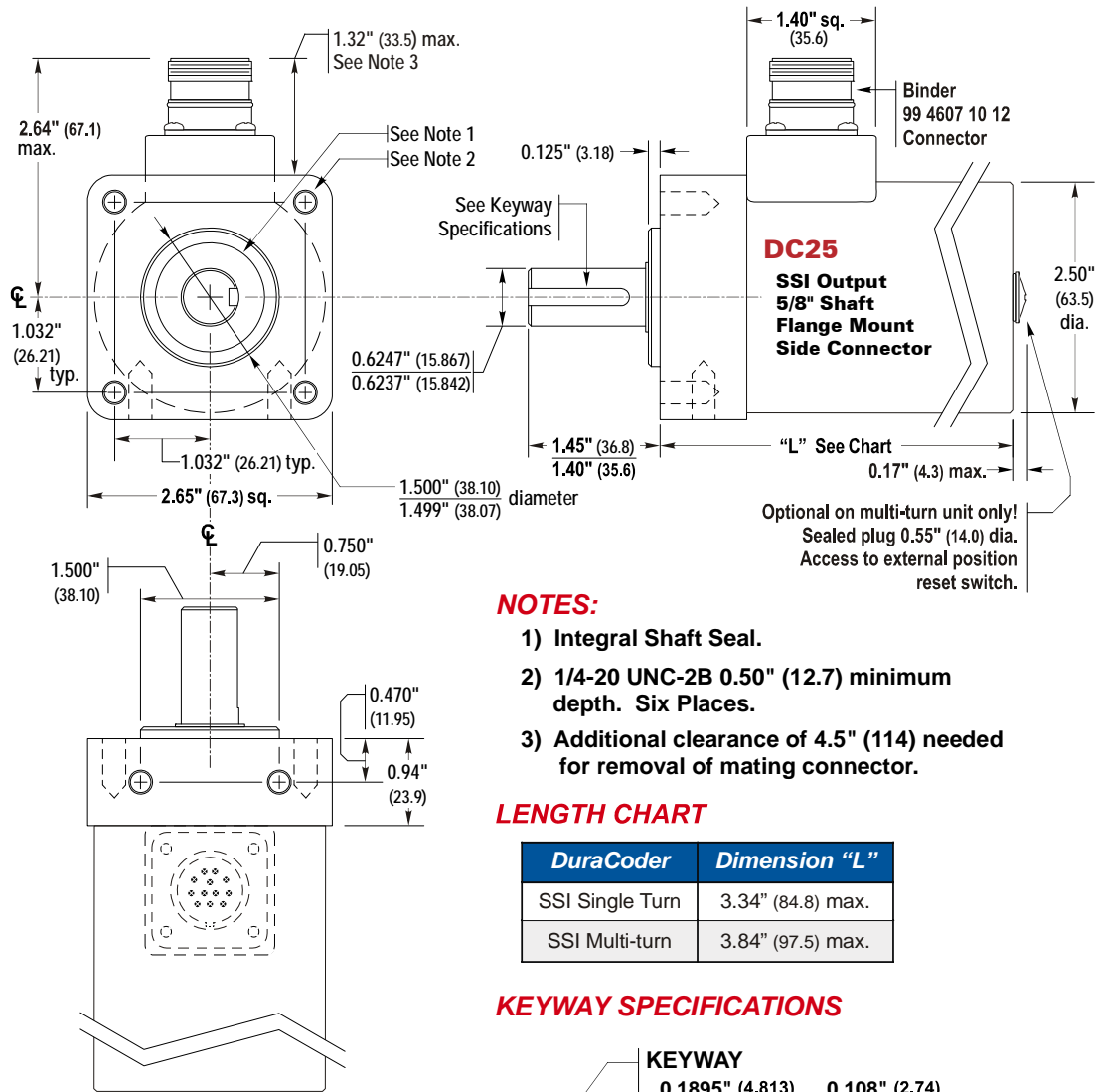

Figure 2.12 Aluminum Body, 5/8" Shaft, Face Mount, End Connector Outline Drawing

5/8" Shaft Face Mount Outline Drawings (continued)

Aluminum Body, Side Connector



NOTES:

- 1) Integral Shaft Seal.
- 2) 1/4-20 UNC-2B 0.50" (12.7) minimum depth. Six Places.
- 3) Additional clearance of 4.5" (114) needed for removal of mating connector.

LENGTH CHART

DuraCoder	Dimension "L"
SSI Single Turn	3.34" (84.8) max.
SSI Multi-turn	3.84" (97.5) max.

KEYWAY SPECIFICATIONS

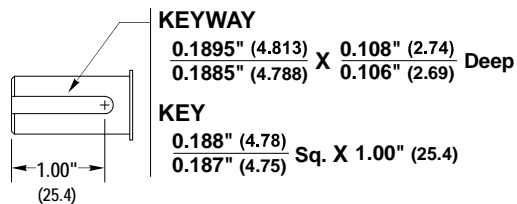

() = Dimensions in millimeters

Figure 2.13 Aluminum Body, 5/8" Shaft, Face Mount, Side Connector Outline Drawing

5/8" Shaft Face Mount Outline Drawings (continued)

316 Stainless Steel Body

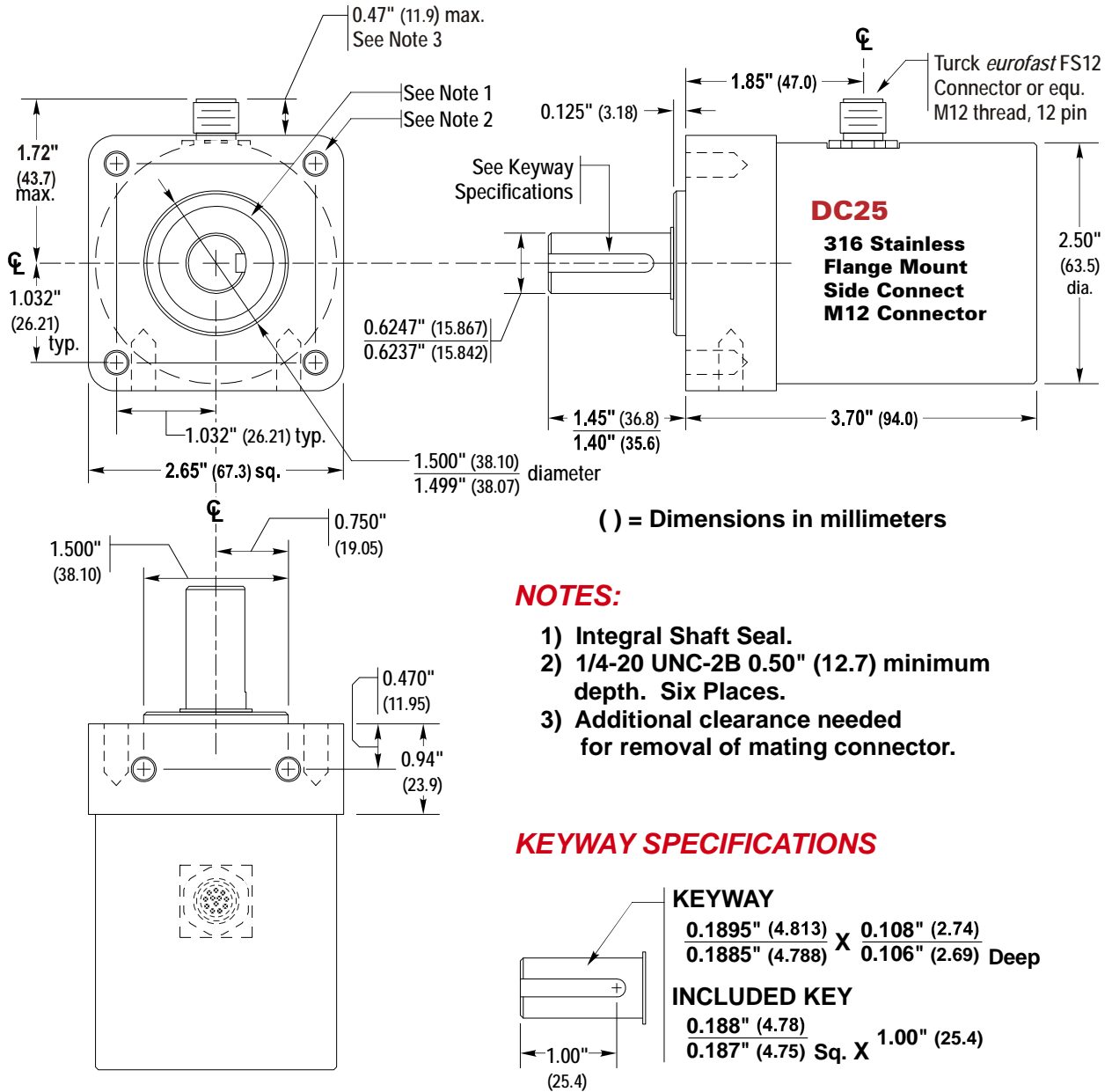

Figure 2.14 316 Stainless Steel Body, 5/8" Shaft, Face Mount, Side Connector Outline Drawing

Shaft Loading

Limit shaft loading to the following values. These values statistically yield an L10 life if 2×10^9 revolutions. (Statistically, only 10% of the bearings will fail after 2×10^9 revolutions.) Shaft loading has an exponential effect on bearing life. The bearings will statistically last longer if you can limit shaft loading below the given values.

Radial Load	Axial Load
100 lbs. (445 N)	50 lbs. (222 N)

Table 2.4 Flange Mount Shaft Loading

Connector Pinouts

Two different connectors are used with the SSI DuraCoder. A nickel plated brass connector is used on our aluminum bodied DuraCoders, while a stainless steel M12 connector is used on our stainless steel models.

Aluminum Body Connector

Below is the pinout of the connector for all aluminum bodied SSI DuraCoders. The connector is manufactured of nickel plated brass by Binder under their part number 99 4607 10 12. Mating connectors are available from AMCI under the part number MS-23.

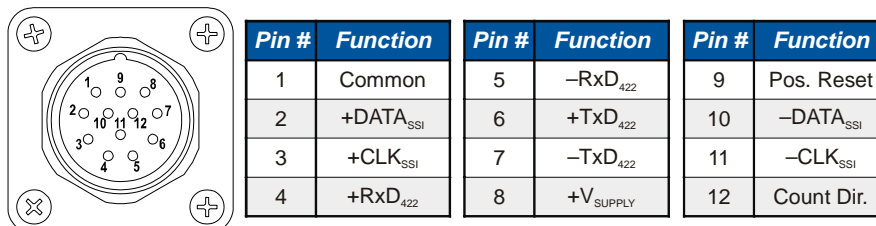
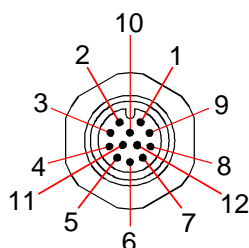

Figure 2.15 Connector Pinout

316 Stainless Steel Body Connector

All SSI DuraCoders with stainless steel bodies use the same 12 pin M12 connector. This connector is the Turck *eurofast FS 12* or equivalent. The pinout for the connector is shown below.



Turck FS 12 or equ.

Pin	Function
1	Common
2	+VSUPPLY
3	+CLK _{SSI}
4	-CLK _{SSI}
5	+DATA _{SSI}
6	-DATA _{SSI}
7	Pos. Reset
8	Count Dir.
9	+RxD ₄₂₂
10	-RxD ₄₂₂
11	+TxD ₄₂₂
12	-TxD ₄₂₂

Mating connectors and cordsets are available under various part numbers. Contact AMCI for further assistance.

Cabling

CSL-(x) Cable

A pre-assembled and tested cable for the aluminum bodied SSI DuraCoder is available from AMCI under the part number CSL-(x), where (x) is its length in feet. The wires at the end of the cable are stripped and tinned and are ready for field termination.

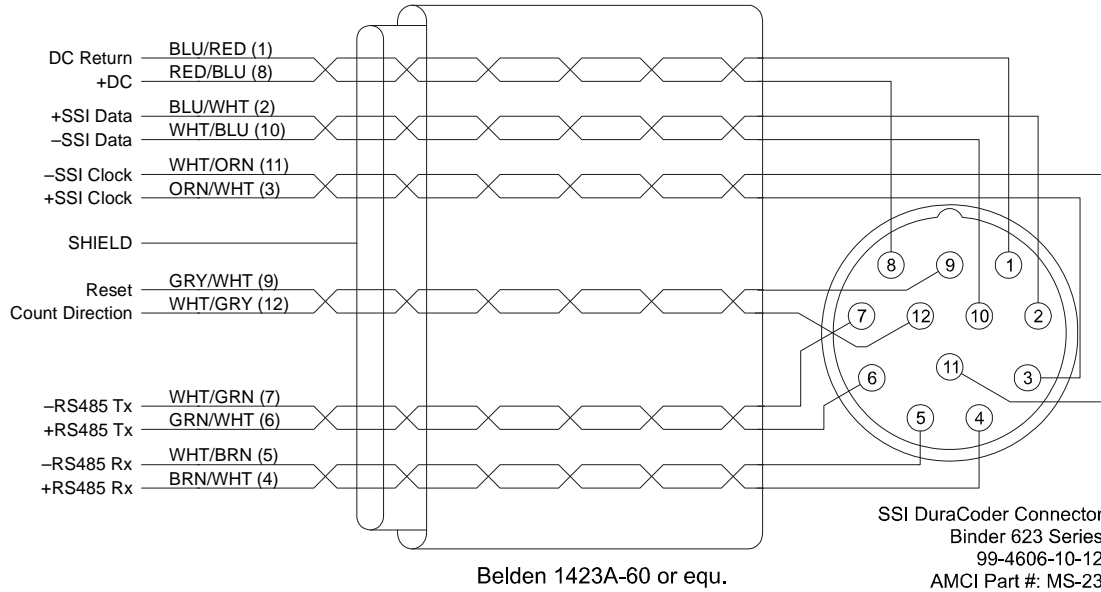

Figure 2.16 CSL-(x) Wiring Diagram

M12 Cordsets

Various types of mating connectors and cordsets for the stainless steel DuraCoders are available from various suppliers including Turck and Binder. Contact AMCI for further assistance.

CONFIGURING THE SSI DURACODER

Most systems allow you to use the default settings of SSI DuraCoder. This chapter explains how to program your SSI DuraCoder if you need to alter the output format (binary or gray code), or the number of counts per turn. You can also alter the number of turns on multi-turn units. Configuration is done through a Windows program available on the AMCI website. With this program you can configure the SSI Output Format, the Full Scale Count and the RS422/485 baud rate. For multi-turn SSI DuraCoders, you can also program the Number of Turns.

Required Equipment

In order to configure the SSI DuraCoder you will need a Windows based PC, an RS422 or RS485 communications port on the PC, a programming cable, a 5 to 24Vdc power supply, and the programming software available on our website.

RS422/485 Comm Port

If you do not have an RS422/485 port, AMCI offers a USB to serial adapter under our part number C485USB-3. Driver installation for this device is straight forward and is documented by the datasheet and driver CD included in the package. The C485USB-3 part number also includes a pre-wired 3 foot cable between the communications port and the SSI DuraCoder. The wiring diagram of the cable is shown in figure 3.1. Note that this cable is for DuraCoders with aluminum bodies. Contact AMCI if you need a cable for the M12 stainless steel connector.

Programming Cable

If your PC already has an RS422 or RS485 communications port, you will still need a cable to connect the port and the DuraCoder. The mating connector for the SSI DuraCoder can be ordered from AMCI with the part number MS-23. The figure to the right shows the pins you need to connect to on the SSI DuraCoder. It also shows the connections from the USB-to-serial adapter sold by AMCI.

CAUTION The pinout is verified for the USB-to-serial adapter available from AMCI. If you are not using this adapter, verify the wiring to your communications port before applying power. If the wiring is incorrect, the SSI DuraCoder or your adapter may be damaged.

NOTE Note that the \pm RxD pair of the SSI DuraCoder is connected to the \pm TxD pair on your communications port and the \pm TxD pair is connected to the \pm RxD pair.

Programming Software

The software used to program the SSI DuraCoder is available on our website. The direct link to the package is

➤ <http://www.amci.com/ssi-config.zip>

This URL was correct at the release of this manual. If the above URL does not work, you will be able to find a link to the current software on the SSI DuraCoder page.

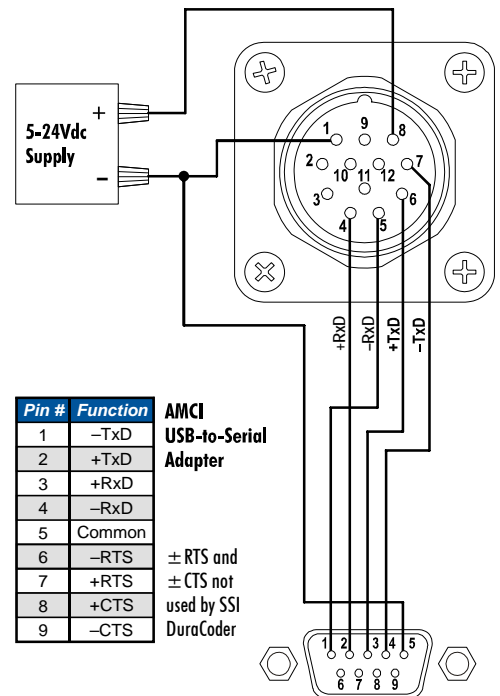

Figure 3.1 SSI DuraCoder serial port wiring

Configuring the RS485/422 Comm Port

This section describes how to configure the C485USB adapter that is available from AMCI. You can skip this section if your computer already has an RS485/422 COM port and you already know its port number.

Check Which COM Ports Are In Use

It is best to determine which COM ports are already in use on your computer before installing the drivers for the C485USB adapter. This will make it easier to determine which COM port the SSI DuraCoder will be attached to.

If you are using Windows XP then the easiest way to determine which COM ports are in use is to call up the Device Manager program. Press the Start button and click on the “Run...” icon. A small window will open that allows you to enter a command in the drop down box. Enter “devmgmt.msc” and press the [OK] button.

The Device Manager program window will open. This program lists all of the devices that are currently installed on your computer and they are broken down into different categories. One of the device categories is named “Ports (COM & LPT)”. Click on the plus sign “+” next to the category name and the list will expand to show the COM and LPT ports already available on the computer.

Make a note of the COM port numbers (COM1, COM2, etc.). Having this information will make it easier to determine which COM port number is taken by the C485USB adapter.

USBCOM Driver CD

Place the included USBCOM mini CD into your computer’s CD drive. A Macromedia Flash program will open if you have Autoplay enabled on your computer. Close this program because it is not needed to install the drivers for the C485USB device.

Driver Installation

- 1) Take the included USB cable and plug the USB style B connector into the C485USB adapter. Plug the USB style A connector into an available USB port on your computer. If you are using a USB hub, it should be a powered hub because the C486USB adapter draws its operating power from the USB port.
- 2) In a few seconds, the “Found New Hardware” window should appear. The program asks if it can connect to Windows Update to find the driver. Click on the radio button that states “No, not at this time” and click [Next].
- 3) Select “Install the software automatically (Recommended)” and click [Next]. The program will find the driver on the USBCOM mini-CD and install it.
- 4) Click on [Finish] to end the program.
- 5) The “Found New Hardware” program will appear again to install the driver fir the “USB Serial Port”. Repeat steps 2 through 4 to complete the installation.

Determine C485USB COM Port Address

If the Device Manager window is still open, right click on any of the devices and select “Scan for hardware changes”. If Device Manager is not open, press the Start button and click on the “Run...” icon. A small window will open that allows you to enter a command in the drop down box. Enter “devmgmt.msc” and press the [OK] button.

If need be, click on the plus sign “+” next to the “Ports (COM & LPT)”category and the list will expand to show the COM and LPT ports already available on the computer. The new port should appear in the list. The description of the port should be “USB Serial Port (COM?)”, where the “?” is a number between 1 and 4.

I Can't Remember the COM Port Number!

If you've previously installed the C485USB serial port and don't remember the COM port number, here's an easy way to figure it out. With the C485USB adapter unplugged, open the Device Manager by pressing the Start button and click on the "Run..." icon. Enter "devmgmt.msc" in the text window and press the [OK] button.

If need be, click on the plus sign "+" next to the "Ports (COM & LPT)" category and the list will expand to show the COM and LPT ports already available on the computer.

Plug the C485USB adapter into the USB cable. In a few seconds, a new COM port will appear whose description is "USB Serial Port". This is the C485USB serial port.

Using the USBProgrammer.exe Program

The download package at <http://www.amci.com/ssi-config.zip> is a zip file that can be opened with any zip file utility. Under Windows XP, the file can be expanded by right clicking on it and selecting "Extract All...". For other operating systems, you may have to download and install a zip file extractor, such as WinZip.

The program itself, titled USBProgrammer.exe, is completely self contained and does not require installation. The included help file must be in the same directory as the program before the program's help function will work. Simply double click on the USBProgrammer.exe icon to start the program.

Figure 3.2 shows the program after you press the [Comm Settings] button. The smaller "Comm Settings" window that opens when you click the [Comm Settings] button allows you to select the COM port assigned to your RS422/485 port. A Baud Rate setting is also shown on the "Comm Settings" window, but it has a fixed value of 9600 baud. You must select the correct COM port and press the [OK] button before you can connect to the SSI DuraCoder.

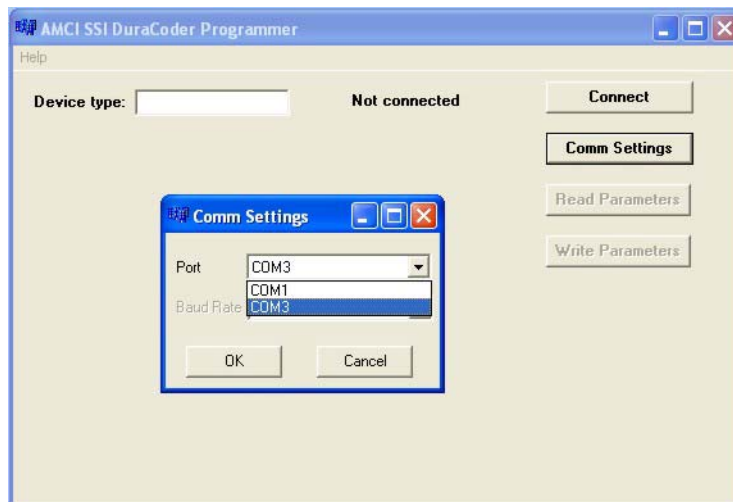

Figure 3.2 COM Port Settings

Using the USBProgrammer.exe Program (continued)

Once the COM port is selected, and power is applied to the SSI DuraCoder, click on the [Connect] button to establish communications with the unit. Figure 3.3 shows the layout of the program screen when the program is communicating with a multi-turn SSI DuraCoder.

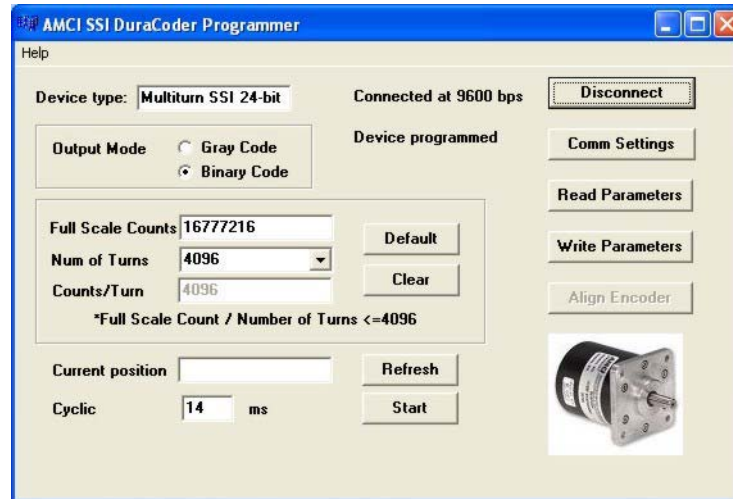

Figure 3.3 USBProgrammer.exe Main Screen

The program is very simple to use, with the data fields taking up most of the screen and the command buttons along the right side.

Data Entry Fields

Output Mode – Allows you to select Binary or Gray Code format for the SSI data.

Full Scale Count – Allows you set the total number of counts generated by the SSI DuraCoder. For single turn units, this parameter has a range of 2 to 4,096 counts. For multi-turn units, range of this parameter is determined by the Number of Turns parameter and has a range of (Number of Turns) to (Number of Turns) * 4,096. For example, if the number of turns equals 8, then the Full Scale Count can range from 8 to 32,768.

Number of Turns – Available only with multi-turn units, this parameter sets the number of turns that must be completed before the position will return to zero. The drop down list allows you to program this parameter to any power of two from 1 to 4,096 turns. Set the Full Scale Count before setting the value.

Command Buttons

Connect/Disconnect – This button establishes or terminates communications with the SSI DuraCoder.

Comm Settings – This button allows you to select the COM port that is attached to the SSI DuraCoder. This choice must be made every time the program is run.

Read Parameters – This button will read the parameter values already programmed into the SSI DuraCoder and display them on the screen.

Write Parameters – This button will write the parameter values down to the SSI DuraCoder

Align Encoder – Not implemented

Current Position Display

In addition to programming the device, the program can also read back and display the current position value of the SSI DuraCoder. Pressing the [Refresh] button will update the position value once. Pressing the [Start] button will continually update the position until you press it again. (The button renames itself to [Stop] when you start the continuous transfer. The time between updates when in continuous mode can be specified in text box labeled “Cyclic”. The update time can be set between 14 and 1000 milliseconds.

RS422/485 COMMUNICATIONS

This chapter details how to read position values and parameter data from an SSI DuraCoder over the RS422/485 link. This information is primarily for users of industrial computers that do not have an SSI interface card.

With the exception of setting the baud rate, information on writing parameter values is not included in this document. AMCI has a Windows compatible program on our website (www.amci.com) for this purpose. This program is called USBProgrammer.exe and is available at <http://www.amci.com/ssi-config.zip>.

The baud rate is not stored in non-volatile memory and defaults to 9600 on every power up. (Just think about what would happen if there was an error storing the baud rate parameter. At best, the baud rate is now a random value. At worst, the baud rate is invalid and all serial communication to the DuraCoder is lost until the unit is repaired.)

RS422/485 Comm Port

This document assumes that your RS422/485 communications port is already installed on your computer and is functioning, which means that any and all drivers needed to support the device are also installed.

If you are using the USB-to-serial adapter sold by AMCI, a driver disk is included with the adapter. If you cannot find the disk, the drivers can be downloaded from the manufacturer's website at:

- http://www.vsc.com.de/produkte/vscom_usb-com-i.html.

DuraCoder Pinout

The figure to the right shows the pins you need to connect to on the SSI DuraCoder. It also shows the connections from the USB-to-serial adapter sold by AMCI. Note that this cable is for DuraCoders with aluminum bodies. Contact AMCI if you need a cable for the M12 stainless steel connector

CAUTION

The pinout is verified for the USB-to-serial adapter available from AMCI. If you are not using this adapter, verify the wiring to your communications port before applying power. If the wiring is incorrect, the SSI DuraCoder or your adapter may be damaged.

Note that the \pm RxD pair of the SSI DuraCoder is connected to the \pm TxD pair on your communications port and the \pm TxD pair is connected to the \pm RxD pair.

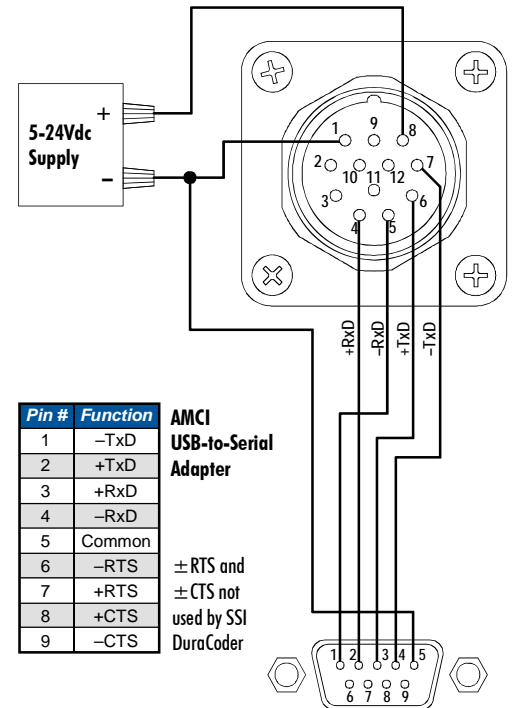

Figure 4.1 SSI DuraCoder serial port wiring

RS422/485 Default Parameters

Your RS422/485 port will have to be set to the same parameter values used by the SSI DuraCoder. SSI DuraCoders have the following default values. Only the baud rate can be changed on the DuraCoder, and this must be done on every power up if you want it to communicate at a rate other than 9600 baud. Information on changing the baud rate is given in the last section of this document.

Parameter	Value
Baud Rate	9600
Data Bits	8
Stop Bits	1
Parity	None
Flow Control	None

Table 4.1 Default COM Parameters

On Windows 2000 and XP systems, port settings can be changed from the Device Manager applet. Click on the [Start] button and select [Run]. In the drop down box type in “devmgmt.msc” and click on [OK]. Find the communications port you’ll be using with the DuraCoder, which usually will be under “Ports (COM & LPT)”. Right click on the communication port and select “Properties” from the menu. In the windows that opens, click on the ‘Port Settings’ tab and change your parameter values.

It may also be possible to set these values in your software when you open the port.

Communications Protocol

The SSI DuraCoder uses a simple polling protocol to exchange information over the RS422/485 link. When reading parameter values or the position data, your program must write a four byte command to the DuraCoder. The DuraCoder immediately responds with the requested information. The DuraCoder then waits for the next request before sending any additional information.

Read Command

The figure below shows the format of the four byte read command. The value of the Parameter ID specifies the data you want back from the DuraCoder. Values for the Parameter ID are also shown.

Byte	Value
1	0x67
2	Parameter ID
3	0x0D
4	0x0A

0x67 = ASCII 'g'
 0x0D = ASCII Carriage Return Code
 0x0A = ASCII Line Feed Code

ID	Read Parameter
1	SSI Output Mode
2	Number of Turns (Multi-turn Units Only)
3	Full Scale Count
4	Baud Rate
5	Encoder Type
6-8	Not Used
9	Position Value

Figure 4.2 Read Command Format

Communications Protocol (continued)

Read Response

Once these four bytes are written to the SSI DuraCoder, it responds with the requested data. Its response is between six and nine bytes long, depending on the length of the data you requested. The figure below shows the general format of the response. If there is an error, the Error Code byte will be non-zero and the Parameter Value is not included. Because of this, all error responses are five bytes long.

Command Code	Parameter ID	Parameter Value	Error Code	Delimiter
0x47	Echo of Parameter ID	Requested Data	Results of Last Command	0x0D / 0x0A
(1 Byte)	(1 Byte)	(1, 2, or 4 Bytes)	(1 Byte)	(2 Bytes)

Figure 4.3 Read Response Format

- 1) The Command Code is always 0x47, which is a 'G' in ASCII.
- 2) The Parameter ID is an echo of the last Parameter ID written to the SSI DuraCoder by the Read Command. This value can be used to determine what data is being sent by the DuraCoder. The meaning of the Parameter ID can be found in figure 4.2 on the preceding page
- 3) An explanation of the available Parameter Values is given in the table below.
- 4) The Error Code byte gives feedback on the present state of communications.
 - 0x00 = No Errors
 - 0x01 = Baud Rate Error (Used with programming only. You will not see this error when reading information from the DuraCoder.)
 - 0x02 = Flash Memory Error (Used with programming only. You will not see this error when reading information from the DuraCoder.)
 - 0x03 = Wrong Command (Command Byte not equal to 0x67)
 - 0x04 = Wrong Parameter ID (Parameter ID not equal to 1, 2, 3, 4, 5, or 9 OR Parameter ID set to 2 when using a single turn SSI DuraCoder.)
 - 0x05 = Wrong Parameter Value (Used with programming only. You will not see this error when reading information from the DuraCoder.)
 - 0x06 = Fatal Error. Cycle power to the SSI DuraCoder. If error still exists, contact AMCI Technical Support for assistance.
- 5) The two byte delimiter are the ASCII codes for 'Carriage Return' and 'Line Feed'

Communications Protocol (continued)**Parameter Lengths, Ranges and Defaults**

Parameter	Length	Range	Default
SSI Output Mode ^a	1 Byte	1 = Gray Code 2 = Natural Binary	Natural Binary
Number of Turns	2 Bytes	1 to 4096	1 if single turn unit 4096 if multi-turn unit
Number of Counts	4 Bytes	2 to (4096*Number of Turns)	4096 if single turn unit 2 ²⁴ if multi-turn unit (4096*4096) (16,777,216)
Baud Rate	1 Byte	0x04=1200 0x05=2400 0x06=4800 0x07=9600 0x08=19200 0x09=38400 0x0A=57600 0x0B=115200	9600
Encoder Type	1 Byte	1 = Single Turn 2 = Multi-Turn	Set by part number

- a. SSI Output Mode refers to the format of the SSI position data. The position data is always transmitted over the serial link in natural binary, right justified to the least significant byte. For example, a position value of 5,460,809 equals 0x535349 and the four bytes that contain the position data would be transmitted as 0x00 0x53 0x53 0x49. Note that these are ordinal numbers, not ASCII characters. In ASCII, the string would be a blank space followed by "SSI".

Table 4.2 Parameter Lengths, Ranges, and Defaults

Setting the Baud Rate**Write Baud Rate Command**

The baud rate is set to 9600 baud on every power up to prevent a situation where you cannot communicate with the DuraCoder because you do not know the baud rate. Changing the baud rate on an SSI DuraCoder requires a five byte Write Baud Rate command. If the unit accepts the command without error, it will write a response to the command at the present baud rate before switching to the new one. If there is an error, the DuraCoder will remain at the present baud rate after its response.

The format of the Write Baud Rate command is shown below.

Byte	Value	ID	Baud Rate
1	0x73	0x04	1200
2	0x04	0x05	2400
3	Baud Rate ID	0x06	4800
4	0x0D	0x07	9600
5	0x0A	0x08	19200
		0x09	38400
		0x0A	57600
		0x0B	115200

0x73 = ASCII 's'
0x0D = ASCII Carriage Return Code
0x0A = ASCII Line Feed Code

Figure 4.4 Write Baud Rate Command

Setting the Baud Rate (continued)**Write Baud Rate Response**

Once the command is accepted, the SSI DuraCoder responds with a five byte reply.

Byte	Value
1	0x53
2	0x04
3	Error Code
4	0x0D
5	0x0A

Error Code	Description
0x00	No Errors
0x03	Byte 1 of the Write Baud Rate command not equal to 0x73.
0x04	Byte 2 of the Write Baud Rate command not equal to 0x04.
0x05	Baud Rate ID outside the range of 0x04 to 0x0B
0x06	Fatal Error. Cycle Power. If problem remains, contact AMCI.

0x53 = ASCII 'S'

0x0D = ASCII Carriage Return Code

0x0A = ASCII Line Feed Code

Figure 4.5 Write Baud Rate Response

After this reply is received, check the Error Code value. If it equals 0x00, the SSI DuraCoder has accepted the command and has switched to the new baud rate.



ADVANCED MICRO CONTROLS INC.

20 GEAR DRIVE, TERRYVILLE, CT 06786 T: (860) 585-1254 F: (860) 584-1973

www.amci.com

LEADERS IN ADVANCED CONTROL PRODUCTS